

ILLUSTRATED PARTS LIST

Pro Mac™ 605 MODELS	SERIAL NUMBER PREFIX
600134-02	11-
600134-03	11-
600134-04	11-
600134-05	11-
600134-06	11-

Super 610 Pro Mac™ 610 MODELS	SERIAL NUMBER PREFIX
600041-01	13-
600041-04	13-
600041-06	13-
600041-08	13-
600041-09	13-
600041-10	13-
600041-11	13-
600041-15	13-
600041-17	13-
600041-21	13-
600041-22	13-
600041-23	13-
600041-24	13-

Pro Mac™ 650 MODELS	SERIAL NUMBER PREFIX
600046-03	12-
600046-07	12-
600046-08	12-
600046-09	12-
600046-10	12-
600046-18	12-
600046-20	12-
600046-21	12-

E.B.® 3.7 MODELS	SERIAL NUMBER PREFIX
600133-02	12-
600133-03	12-
600133-04	12-
600133-05	12-

SUPER 610 PRO MAC™ 605, 610 645, 650, 655 and EAGER BEAVER® 3.7 CHAIN SAWS

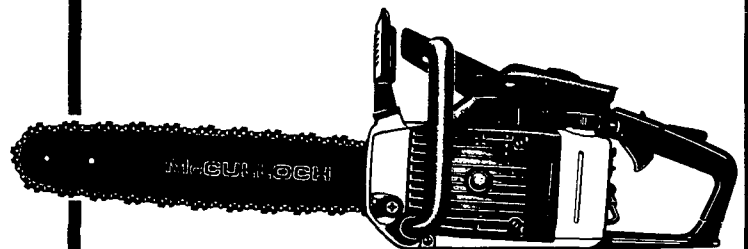

McCulloch and Eager Beaver® chain saws are identified by a model number (in this instance, 600041, 600046, etc.) followed by a suffix number (01, 02, etc.) stamped on the identification plate attached to the saw. Suffix letters denote variations in parts or assemblies in the manufacture of the saw.

Part numbers listed in this I.P.L. which have a circled number ② or numbers preceding the description, are used only on the model or models identified by a circled number ② or numbers.

Part numbers which have one or more dots (.) preceding their descriptions may be ordered individually, but they are also included in the kit or assembly whose description begins directly above the dot(s).

The policy of McCulloch Corporation is one of continual improvement in design, manufacturing and engineering advancement wherever possible to assure still finer two-cycle power tools. Hence, specifications, equipment, colors, design and manufacturer's suggested list prices are subject to change without notice and McCulloch Corporation reserves the right to make such changes without prior notification or obligation to backfit or supply backfit components for units previously shipped from the factory.

JANUARY 1987

- CONTENTS -

	Page
FIGURE 1 - General	2
FIGURE 2 - Powerhead and Oiler Asys.	4
FIGURE 3 - Carburetor Asy. all models except PM 650.....	6
FIGURE 4 - Carburetor Asy. for PM 650 ...	7
FIGURE 5 - Chain Brake Assembly.....	8
FIGURE 6 - Fan Housing & Fuel Tank Asys..	8
FIGURE 7 - Specifications	9
FIGURE 8 - Bar/Chain/Sharpening Tools ...	9
FIGURE 9 - Tools and Accessories	9
SERVICE NOTES - Piston Rings	10



218689-01-E

Figure 1 GENERAL ASSEMBLY

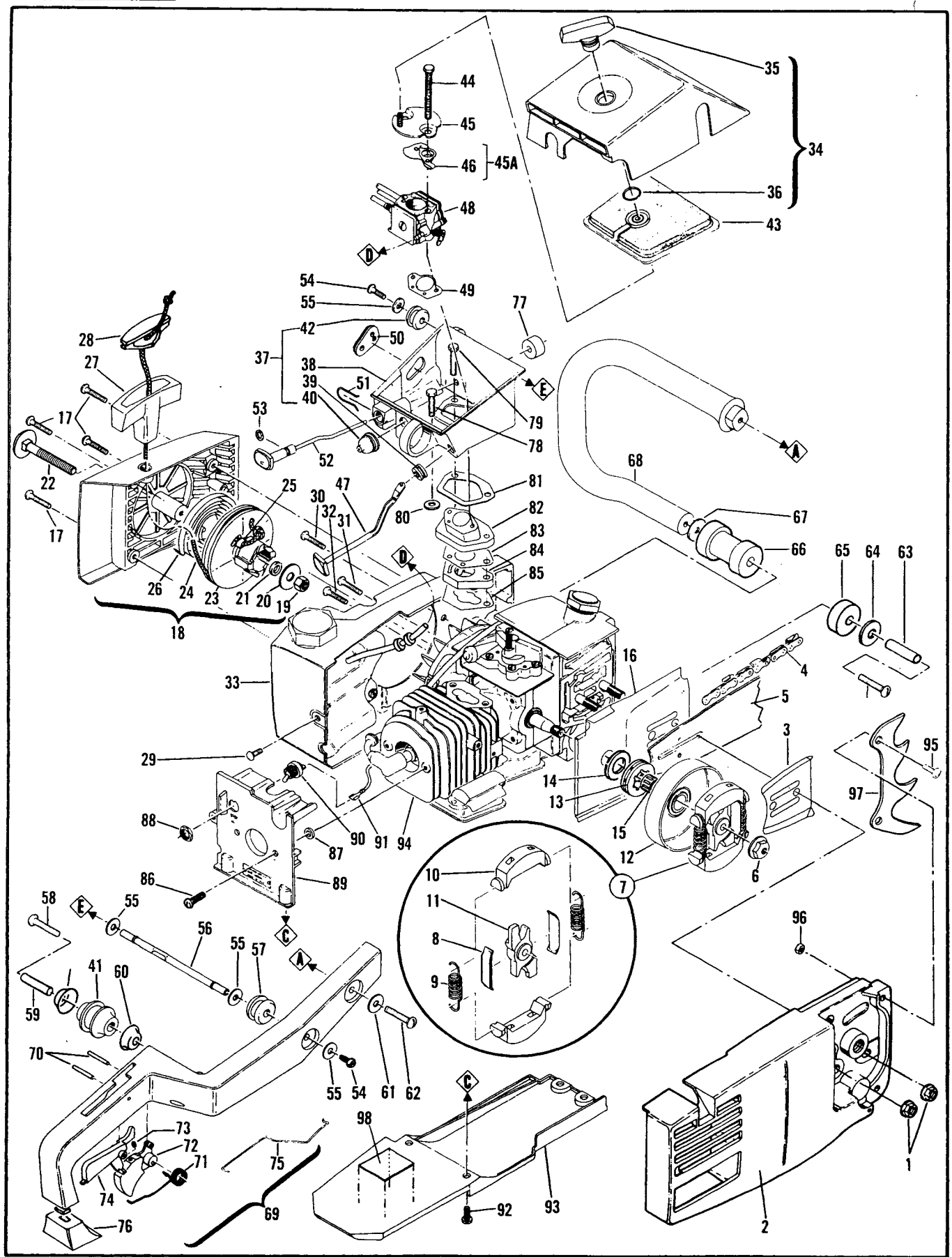

FIGURE 1 GENERAL ASSEMBLY

ITEM NO.	PART NUMBER	DESCRIPTION	UNITS PER ASY.
1	216645	Nut-Hex Flange	2
2	Fig. 2	Chain Brake Assembly	1
3	64325	Plate-Bar Guide	1
4	Fig. 7	Chain Assembly	1
5	Fig. 7	Bar Assembly	1
6	92457	Nut-Hex Flange M10 x 1.25 (160-170 in. lb. torque)	1
7	214301	Clutch Assembly	1
8	64583	. Retainer-Clutch Spring	2
9	83223	. Spring-Clutch	2
10	67233	. Kit-Clutch Shoe	1
11	214300	. Rotor-Clutch	1
12	214979 ①	Drum/Sprocket Assy.	1
	214200 ②	Drum/Hub Assy.	1
13	86951 ②	Sprocket-Rim .375P	1
14	86958 ②	Washer-Shim	1
15	110971	Bearing-Needle	1
16	92354	Jacket-Cylinder	1
17	120081	Screw-Pan Hd M4 x 16 (15-20 in. lb. torque)	4
18	219159	Starter Assembly	1
19	111038	.Nut-1/4-20 (25-30 in. lb. torque)	1
20	95401	. Washer-Starter	1
21	216589	. Spacer-Starter	1
22	215848	. Step Bolt-Starter	1
23	219163	. Drum/Rope Kit-Starter	1
24	87670	.. Rope-Starter	1
25	217730	.. Bushing-Rope	1
26	87668	. Spring-Starter Rewind	1
27	93137	Starter Handle	1
28	214699	Insert Handle	1
29	120002	Screw-Pan Hd M5 x 14 (30-35 in. lb. torque)	1
30	93232	Screw-Fan Housing M5 x 40 (45-50 in. lb. torque)	1
31	93233	Screw-Fan Housing M5 x 35 (45-50 in. lb. torque)	1
32	93234	Screw-Fan Housing M5 x 30 (45-50 in. lb. torque)	1
33	Fig. 3	Fan Housing/Fuel Tank Assy	1
34	217651	Cover Assy-Filter	1
35	91991	. Knob-Air Filter Cover	1
36	110565	. Ring-Retaining	1
37	95216	Air Box Assembly	1
38	95214	. Box-Air	1
39	93261	. Grommet-Choke	1
40	69597	. Boot-Control Rod	1
41	92065	. Isolator	1
42	93253	. Grommet-Strut	1
43	214226	Filter-Air	1
44	120004	Screw-Hx Hd M5 x 56 (35-40 in. lb. torque)	2
45	91938	Bracket Assy-Filter/Cover	1
45A	94482	Choke & Rod Kit	1
46	94151	. Choke-Carburetor	1
47	94171	. Rod-Choke	1
48	Fig. 3,4	Carburetor Assembly	1
49	91924	Gasket-Carburetor	1
50	91995-01	Grommet-Carburetor Needle	1

ITEM NO.	PART NUMBER	DESCRIPTION	UNITS PER ASY.
51	93458	Clip-Oiler Button	1
52	92067-01	Button/Rod Assy-Oiler	1
53	105614	'O' Ring	1
54	215266	Screw-Pan M5 Special (25-30 in. lb. torque)	2
55	110990	Washer	4
56	93252-01	Strut-Handle	1
57	93253	Grommet-Strut	1
58	111015	Screw-Pan Hd 1/4-14 x 2.5 (70-80 in. lb. torque)	2
59	92071	Spacer	1
60	92066	Cup-Isolator	2
61	102115	Washer-Plain	1
62	111014	Screw-Pan Hd 1/4-14 x 1.75 (70-80 in. lb. torque)	1
63	92071	Spacer	1
64	111027	Washer-Plain	1
65	93913	Isolator	1
66	94140	Isolator	1
	94847 ③	Isolator	1
67	111027	Washer-Plain	1
68	91951	Frame	1
69	214723	Handle Assembly	1
70	110994	. Pin-Roll	2
71	93771	. Spring-Trigger	1
72	93538-01	. Trigger	1
73	111013	.. Screw-Set	1
74	91955	. Release-Trigger	1
75	214504	. Rod-Throttle	1
76	93459	Boot-Handle	1
77	92161	Seal-Air Box	1
78	120037	Screw-Hx Hd M5 x 25 (Sems) (35-40 in. lb. torque)	1
79	120039	Screw-Hx Hd M5 x 30 (Sems) (35-40 in. lb. torque)	2
80	93460	Washer-Insulator	1
81	94018	Gasket-Air Box	1
82	94017-01	Insulator-Carburetor	1
83	91933	Gasket-Air Box	1
84	91934	Insulator-Air Box	1
85	92038	Gasket-Insulator	1
86	120037	Screw-Hx Hd M5 x 25 (Sems) (45-50 in. lb. torque)	2
87	93460	Washer-Insulator	2
88	104810	Nut-Hx 15/32-32 (30-35 in. lb. torque)	1
89	218561	Shroud-Cylinder	1
90	93890	Switch-Ignition	1
91	92466	Wire Assembly-Switch	1
92	120002	Screw-Pan Hd M5 x 14 (45-50 in. lb. torque)	4
93	214670	Shroud-Bottom	1
94	Fig. 6	Powerhead & Oiler Assy	1
95	120002 ④	Screw-Pan Hd M5 x 14	2
96	120044 ④	Nut-Hx M5 Lock	2
97	93668 ④	Spike	1
98	219058	Safety Decal	1

① Used on all models except PM 650.

② Used on all PM 650 Models.

③ Pm 650 Model 600046-10 uses only one (1) Isolator, p/n 94847, in place of two (2) Isolators, one (1) p/n 93913 and one (1) p/n 94140.

④ PM 610 Models: 41-01, -02
128-05, -06
PM 650 Models: 46-02, -11, -19

NOTE:
PM 650 Models 46-01, -03, -04, -07, -08, -19 use four (4) screws, two (2) nuts and two (2) spikes.

Figure 2 Powerhead & Oiler Assembly

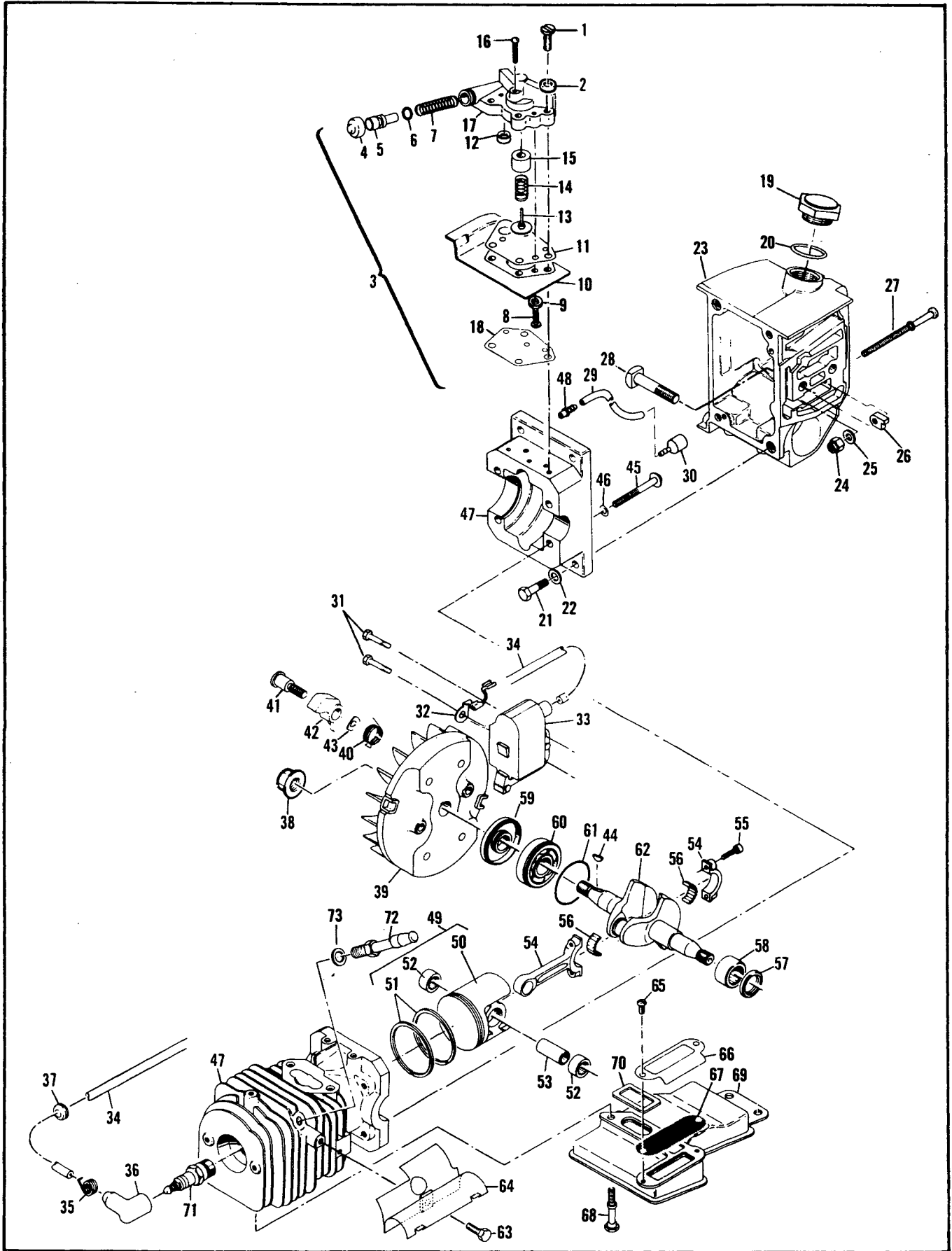

FIGURE 2 POWERHEAD & OILER ASSEMBLY

ITEM NO.	PART NUMBER	DESCRIPTION	UNITS PER ASY.	ITEM NO.	PART NUMBER	DESCRIPTION	UNITS PER ASY.	
1	120036	Screw-Pan Hd M4 x 25 (Sems) (10-15 in. lb. torque)	4	44	100106	Key-Woodruff	1	
2	67177	Washer-Insulating	4	45	62106	Screw-Wsh. Hd 12-24 x 1 3/4 (70-75 in. lb. torque)	4	
3	219380	Pump Assy-Oiler (Pulse)	1	46	111025	Washer-Sealing	4	
4	215151	.Cap-Oil Pump	1	47	94536	Cyl/C'Case Assembly	1	
5	93933	.Plunger-Oil Pump	1	①	218814	Cyl/C'Case Assembly	1	
6	105614	.'O' Ring	1	48	92096	.Nipple-Oil Line	1	
7	66687	.Spring-Plunger	1	49	②	94130	Piston Assembly	1
8	110706	.Screw-Pan Hd 8-18 x .50 (10-15 in. lb. torque)	3	①	219269	Piston Assembly	1	
9	216354	.Gasket Washer	1	50	-- --	.Piston	1	
10	217218	.Cover-Diaphragm	1	①	92514	.Piston-1.807	1	
11	216992	.Diaphragm-Oiler	1	51	②	94132	.Ring Set-Piston	1
12	217217	.Valve-Oiler	1	①	92517	.Ring Set-Piston	1	
13	91945	.Piston Assembly-Pulse	1	52	111021	.Bearing-Needle	2	
14	94322	.Spring-Return	1	53	87710	.Pin-Piston	1	
15	91944	.Sleeve-Oil Pump	1	54	85352	Rod Assembly-Connecting	1	
16	218530	.Screw-Hex/Slot 6-40 x .875	1	55	61627-01	.Screw-Con Rod (55-65 in. lb. torque)	2	
17	217202	.Body-Assembly-Oil Pump	1	56	63225	Roller Bearing-Needle (set of 20)	1	
18	91950	Gasket-Oil Pump	1	57	110260	Seal-Oil .625 I.D. x .875	1	
19	216052	Cap w/Retainer-Oil	1	58	104357	Bearing-Needle	1	
20	101148	'O' Ring	1	59	67906	Seal-Oil	1	
21	120006	Screw-H5 Hd M6.3 x 24 (75-80 in. lb. torque)	4	60	67905	Bearing Ball	1	
22	100004	Washer-Pl. .265 I.D. x .032	4	61	63464	Ring-Snap	1	
23	218583	Tank Assembly-Oil	1	62	217041	Crankshaft	1	
24	110950	.Nut-Lock	1	63	102762	Screw-Hx Hd 10-24 x 1/2 (55-60 in. lb. torque)	1	
25	102115	.Washer-Plain	1	64	217607	Deflector-Exhaust	1	
26	91982	.Nut-Bar Adjustment	1	65	120038	Screw-Pan M4 x 8 (34-45 in. lb. torque)	2	
27	94362	.Screw-Bar Adjustment	1	66	93481	Plate-Deflector	1	
28	92459	.Bolt-Bar	2	67	94958	Screen-Muffler	1	
29	92616	Hose-Oil Pickup	1	68	95444	Screw-Muffler (65-75 in. lb. torque)	2	
30	92465	Pickup-Oil	1	69	93603	Muffler Assembly	1	
31	120037	Screw-Hx M5 x 25 (Sems) (55-60 in. lb. torque)	2	70	84007	Gasket-Muffler	1	
32	84686-01	Wire Assembly	1	71	235593	Spark Plug (120 in. lb. Torque)	1	
33	95553	Ignition Assembly-Electronic	1	72	③	214304	Valve-DSP	1
34	95270	.Wire Assembly-Spark	1	73	③	214765	Washer-DSP Valve	1
35	102556	..Connector-Spark Plug	1					
36	95266	..Boot-Spark Plug	1					
37	110995	.Grommet-Spark Plug Wire	1					
38	94500	Nut-Hx Flange M10 (265-325 in. lb. torque)	1					
39	216739	Flywheel/Pawl Assembly	1					
40	93144	.Spring-Starter	2					
41	95362	.Screw-Starter Pawl	2					
42	95361	.Pawl-Starter	2					
43	213253	.Washer-Spring	2					

① Use on PM 605, 645 only.

② Before ordering piston ring set for your PM 610, PM 650, PM 655 see service notes on Page 10.

③ Used on all PM 650 models equipped with a DSP valve.

Figure 3 CARBURETOR ASSEMBLY

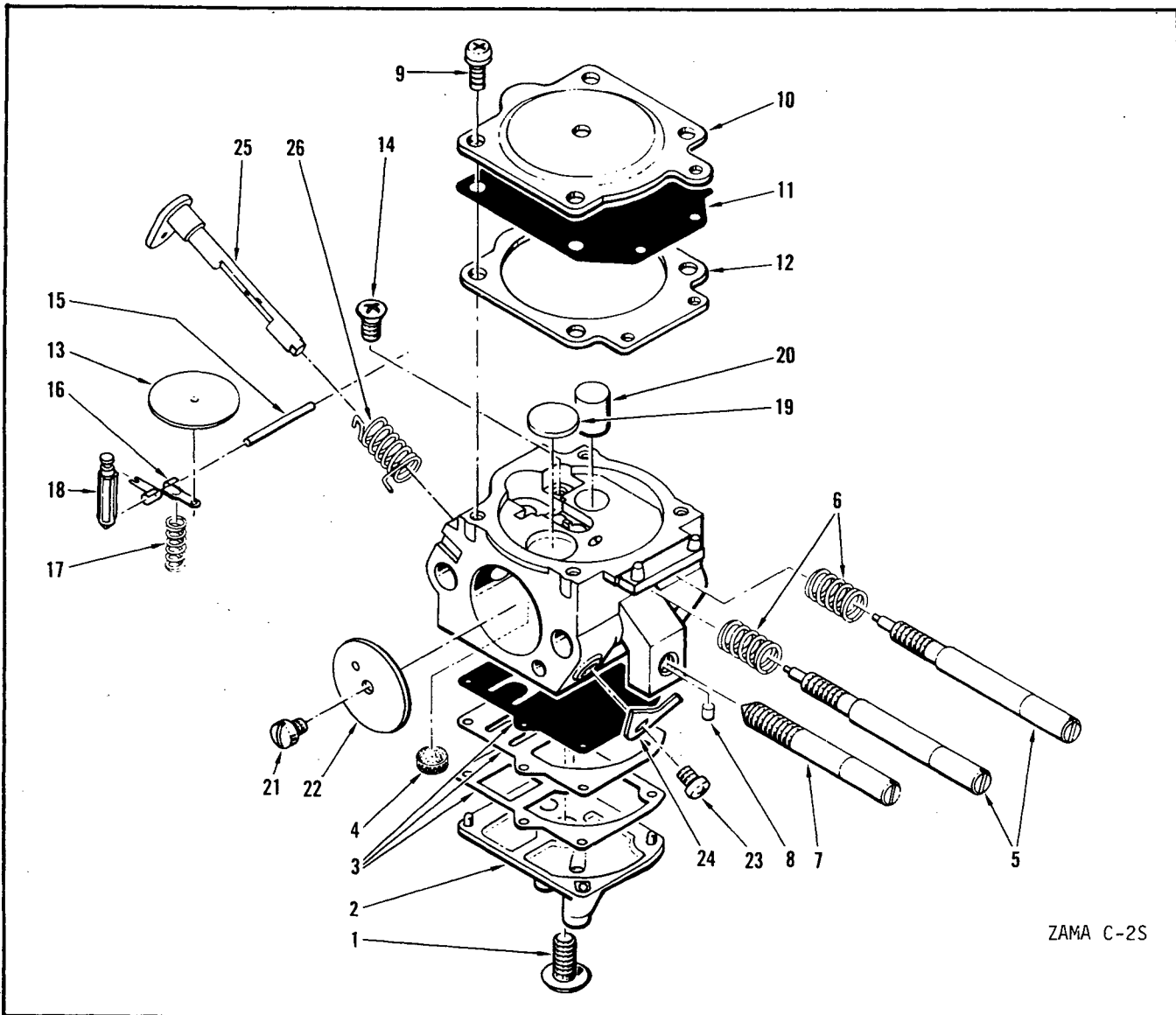

ZAMA C-2S

ITEM NO.	PART NUMBER	DESCRIPTION	UNITS PER ASY.
	95763	Carburetor Asy. (Zama C-2S)	
1	-	. Screw - Pump Cover	1
2	214954	. Cover - Pump	1
3	-	①② . Kit - Pump Diaphragm	1
4	-	① . Screen - Filter	1
5	-	① . Screw - Adjustment	2
6	-	① . Spring - Adjustment Screw	2
7	-	. Screw - Throttle Adjustment	1
8	-	. Piece - Friction	1
9	93945	. Screw - Diaphragm Cover	4
10	214945	. Cap	1
11	-	①② . Diaphragm - Main	1
12	-	①② . Gasket - Main	1
13	-	① . Disk	1

ITEM NO.	PART NUMBER	DESCRIPTION	UNITS PER ASY.
14	91814	② . Screw Pin Lever	1
15	93942	① . Pin - Arm	1
16	-	② . Arm - Needle Valve	1
17	-	② . Spring - Arm	1
18	-	① . Valve - Needle	1
19	93951	. Plug - Welsh	1
20	-	① . Orifice - Main Fuel	1
21	-	. Screw - Plate	1
22	-	. Valve - Throttle	1
23	-	. Screw	1
24	-	. Lever - Throttle Adjustment	1
25	-	. Shaft Assembly - Throttle	1
26	-	. Spring - Throttle Return	1

NOTE: Used on all models except PM 650.

① Contained in Repair Kit, P/N 214959.

② Contained in Gasket/Diaphragm Kit, P/N 218892.

NOTE: Items are listed for identification and disassembly sequence purposes and only those items with part numbers listed or items included in the repair kits are available as service parts.

CARBURETOR ASSEMBLY

Figure 4

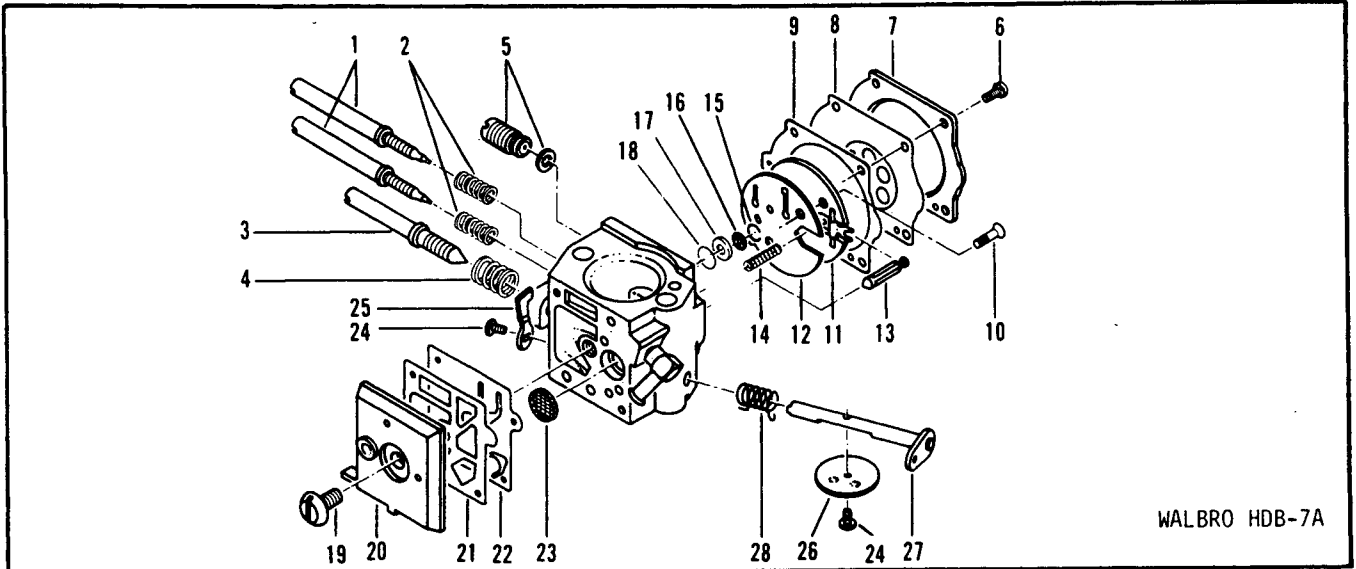

WALBRO HDB-7A

ITEM NO.	PART NUMBER	DESCRIPTION	UNITS PER ASY.
	95631	Carburetor - Walbro HDB-7A (PM 650)	
1	- - ①	. Needle - Hi Speed & Idle	2
2	- - ①	. Spring - Needle Adjustment	2
3	- -	. Screw - Idle	1
4	- -	. Spring - Idle Adjustment	1
5	- -	. Governor Asy. (HDB-7A Only)	1
6	- -	. Screw - Metering Cover	4
7	- -	. Cover - Metering Diaphragm	1
8	- - ① ②	. Diaphragm Asy. - Metering	1
9	- - ① ②	. Gasket - Metering Diaphragm	1
10	- - ①	. Screw - Circuit Plate	1
11	- - ①	. Plate Assembly - Circuit	1
12	- - ① ②	. Gasket - Circuit Plate	1

ITEM NO.	PART NUMBER	DESCRIPTION	UNITS PER ASY.
13	- - ① ②	. Valve - Inlet Needle	1
14	- - ① ②	. Spring - Metering Lever	1
15	- - ① ②	. Ring - Screen Retaining	1
16	- - ① ②	. Screen - Check Valve	1
17	- -	. Retainer - Check Valve	1
18	- -	. Valve - Check	1
19	- -	. Screw - Fuel Pump Cover	1
20	- -	. Cover - Fuel Pump	1
21	- - ① ②	. Gasket - Fuel Pump	1
22	- - ① ②	. Diaphragm - Fuel Pump	1
23	- - ① ②	. Screen - Inlet	1
24	- - ①	. Screw - Valve	2
25	- -	. Stop - Throttle	1
26	- -	. Valve - Throttle	1
27	- -	. Shaft Assembly - Throttle	1
28	- - ①	. Spring Throttle Return	1

① Contained in Major Repair Kit, P/N 217075. 224146

② Contained in Minor Repair Kit, P/N 217077. 224143

NOTE: Items are listed for identification and disassembly sequence purposes and ONLY those items included in the Major and Minor Repair Kits are available as service replacement parts.

Figure 5 CHAIN BRAKE® ASSEMBLY

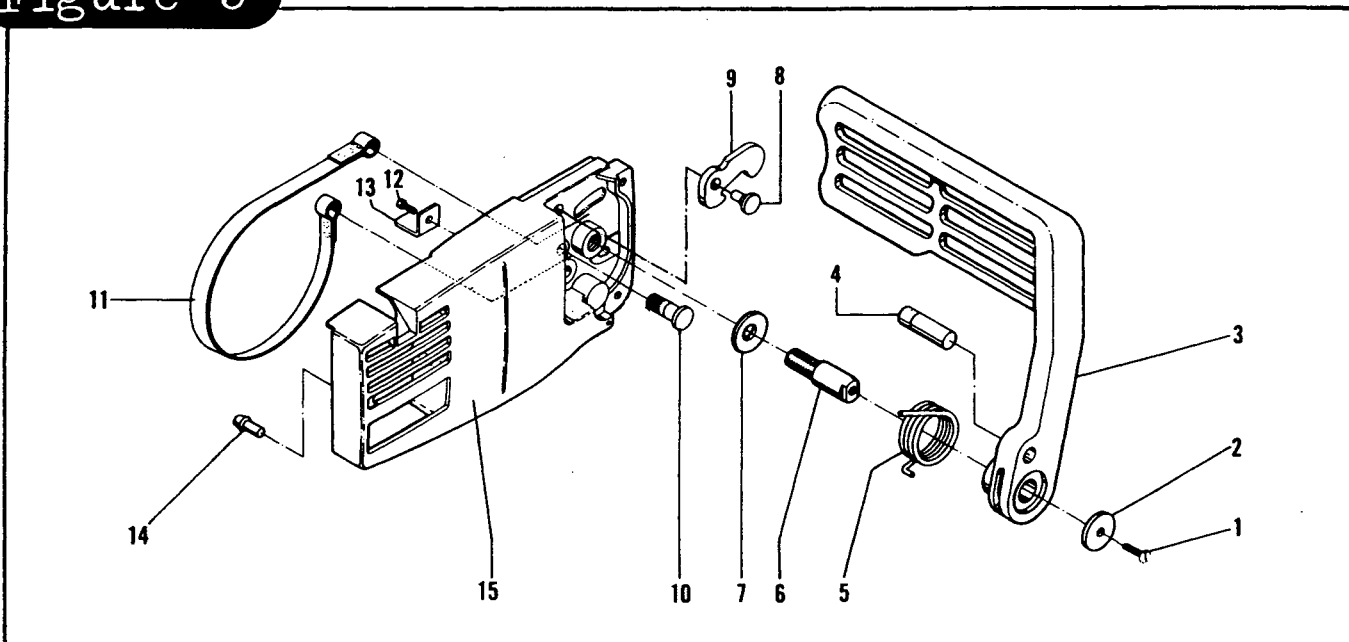

ITEM NO.	PART NUMBER	DESCRIPTION	UNITS PER ASY.
	217697	Brake Assembly	1
1	216634	. Screw 10 24 x .50	1
2	216633	. Washer-Plain	1
3	217115	. Flag Assembly-Brake	1
4	214366	. Pin Assembly-Roller	1
5	93085	. Spring-Brake	1
6	91246	. Pin-Lever Pivot	1
7	91245	. Washer-Thrust	1
8	94144	. Pivot-Latch	1

ITEM NO.	PART NUMBER	DESCRIPTION	UNITS PER ASY.
9	217235	. Latch	1
10	93082	. Pin-Band Anchor	1
11	93081	. Band-Brake	1
12	216687	. Screw-M5 x 14.25	1
13	92178	. Stop-Chain	1
14	92086	. Snubber-Brake Housing	1
15	217698	. Housing-Brake	1

Figure 6 Fan Housing & Fuel Tank Assemblies

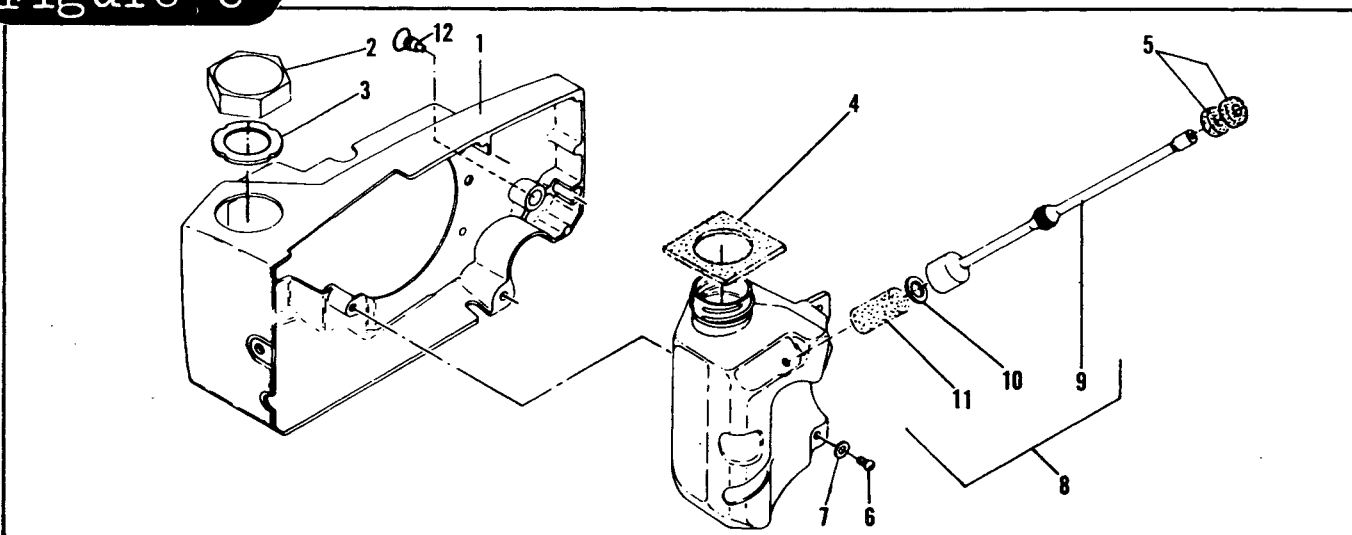

ITEM NO.	PART NUMBER	DESCRIPTION	UNITS PER ASY.
1	216154	Housing-Fan	1
2	216157	Cap/Retainer Assembly-Fuel	1
3	94707	. Gasket-Fuel Cap	1
4	93251	Seal-Fuel Vent	1
5	92161	Seal-Air Box	2
6	120068	Screw-Pan Hd M4 x 12 (SEMS)	2

ITEM NO.	PART NUMBER	DESCRIPTION	UNITS PER ASY.
7	69322	Washer-Hard No. 8	2
8	94901	Tank Assembly-Fuel	1
9	94899	. Hose Assembly-Fuel	1
10	100440	. Washer-5/16	1
11	63932	. Filter-Fuel	1
12	216316	Plug-Push	1

① Used only if your unit is so equipped.

SPECIFICATIONS Figure 7

Displacement PM 610/650/E.B. 3.7	3.7 cu. in. (60cc)
PM 605.	3.5 cu. in. (58cc)
Bore and Stroke PM 610/650/E.B. 3.7.	1.9 in. x 1.5 in. (4.7mm to 35mm)
PM 605	1.8 in. x 1.375 in. (40mm x 35mm)
Ignition	Electronic (C.D.I.)
Lamination Gap011 in. to .015 in. (.28mm to .38mm)
Timing	26 BTDC
Spark Plug Gap025 in. (.63mm)
Clutch Engagement Speed.	2800 to 3000 RPM
Idle Speed	1800 to 2000 RPM
Fuel Tank Capacity	17.3 Ounces (510cc)
Fuel Type.	Regular Grade Leaded or Unleaded Gas
Fuel/Oil Mixture	40:1 Using McCulloch Oil
	20:1 Using SAE Two Cycle
Oil Tank Capacity.	14.6 Ounces (430cc)
Main Bearings.	Needle and Ball
Connecting Rod Bearings.	Needle
Weight (Power Unit Only) All except PM 650	14.7 Lbs.
PM 650.	14.8 Lbs.

Figure 8 Bar/Chain/Chain Sharpening Tools

PART NUMBER	BAR DESCRIPTION	PART NUMBER	CHAIN DESCRIPTION	FILE PLATE PART NUMBER	ROUND FILE PART NUMBER
214237	Sprocket Tip 16"	218839-12	PMR370 GLX-60CL	219132	219161* 56698-23**
217025	Sprocket Tip 18"	218062-12	PMR370 GLX-66CL	219132	219161* 56698-23**
214238	Sprocket Tip 20"	218069-12	PMR370 GLX-70CL	219132	219161* 56698-23**

* 7/32" Round File Twin Pack
 ** 7/32" Round File 12-Pack

TOOLS & ACCESSORIES Figure 9

PART NUMBER	DESCRIPTION	PART NUMBER	DESCRIPTION
215432	Pressure Test Tool	93770	Case Custom Lubricant 40:1
63137	Adaptor - Exhaust		Case Contains 48 cans 6 ounces
94415	Adaptor - Intake	95159	Allen Wrench - 5mm
84223	Kit - Piston Tools	69794	Locquic
95218	Air Filter - Felt	110083	R.T.V. Sealant
214221	Scrench	94121	Kit - Carrying Case 20 Inches
214195	Gun-Lube (Disposable)	214203	. Scabbard 20 Inches
214194	Gun-Lube (Deluxe)	214208	Kit - Spike
85707	Case - Custom Lubricant 40:1		
	Case contains 24 cans 16 ounces		

SERVICE NOTES:

PM 610 PISTON RINGS

Piston rings used on PM 610 Chain saws built before February 1984 are different than piston rings used on PM 610 units built since 1984. The rings are not interchangeable.

BEFORE FEBRUARY 1984

PM 610 Piston Rings (Thick)

If PM 610 being serviced is equipped with the thicker piston ring as illustrated in ACTUAL SIZE below, order p/n 94133.

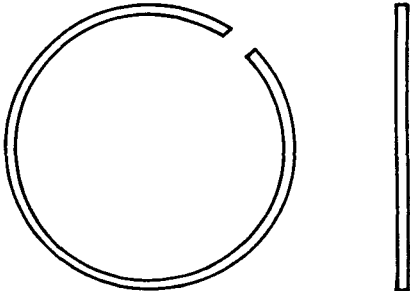

SINCE FEBRUARY 1984

PM 610 PISTON RINGS (Thin)

If PM 610 being serviced is equipped with the thinner piston ring as illustrated in ACTUAL SIZE below, order p/n 94132.

