

**Spare Parts List**  
**Ersatzteilliste**  
**Liste de pièces détachées**  
**Lista de piezas de repuesto**

2009-10

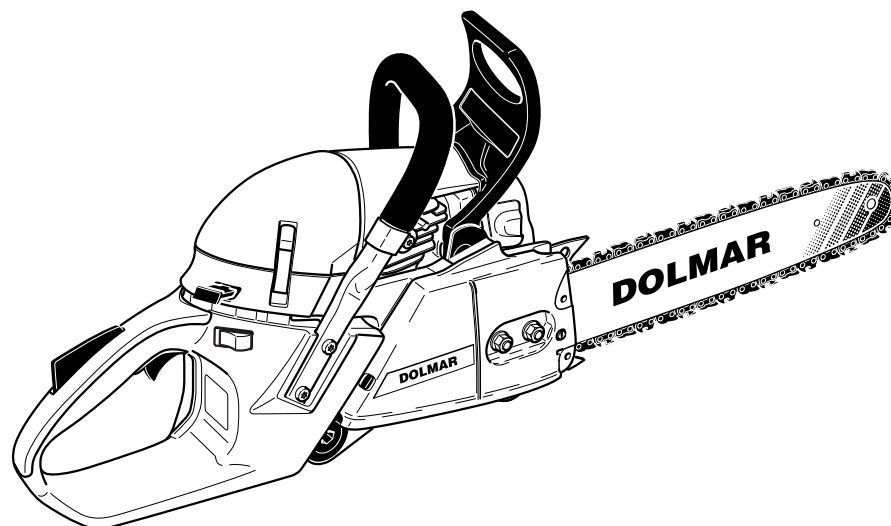

PS-630  
PS-6400  
PS-7300  
PS-7900  
PS-6400 D  
PS-7300 D  
PS-7900 D  
PS-6400 H  
PS-7300 H  
PS-7900 H  
PS-6400 DH  
PS-7300 DH  
PS-7900 DH  
PS-6400 (USA)  
PS-7300 (USA)  
PS-7900 (USA)  
PS-6400 H (USA)  
PS-7300 H (USA)  
PS-7900 H (USA)

**DOLMAR**



A member of the *Makita* Group

995700059 (D, GB, F, E)

PS-630, PS-6400, PS-7300, PS-7900, PS-6400 D, PS-7300 D, PS-7900 D, PS-6400 H, PS-7300 H, PS-7900 H, PS-6400 DH, PS-7300 DH, PS-7900 DH, PS-6400 , PS-7300 , PS-7900 , PS-6400 H , PS-7300 H , PS-7900 H

1

Kraftstofftank, Bügelgriff  
Fuel tank, tubular grip  
Réserv. carburant, poignée tubulaire  
Depósito de combustible, mango tubular

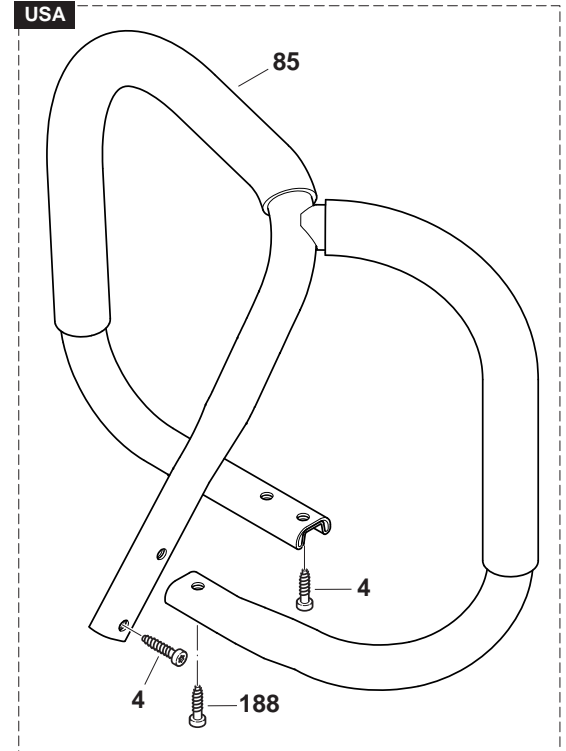
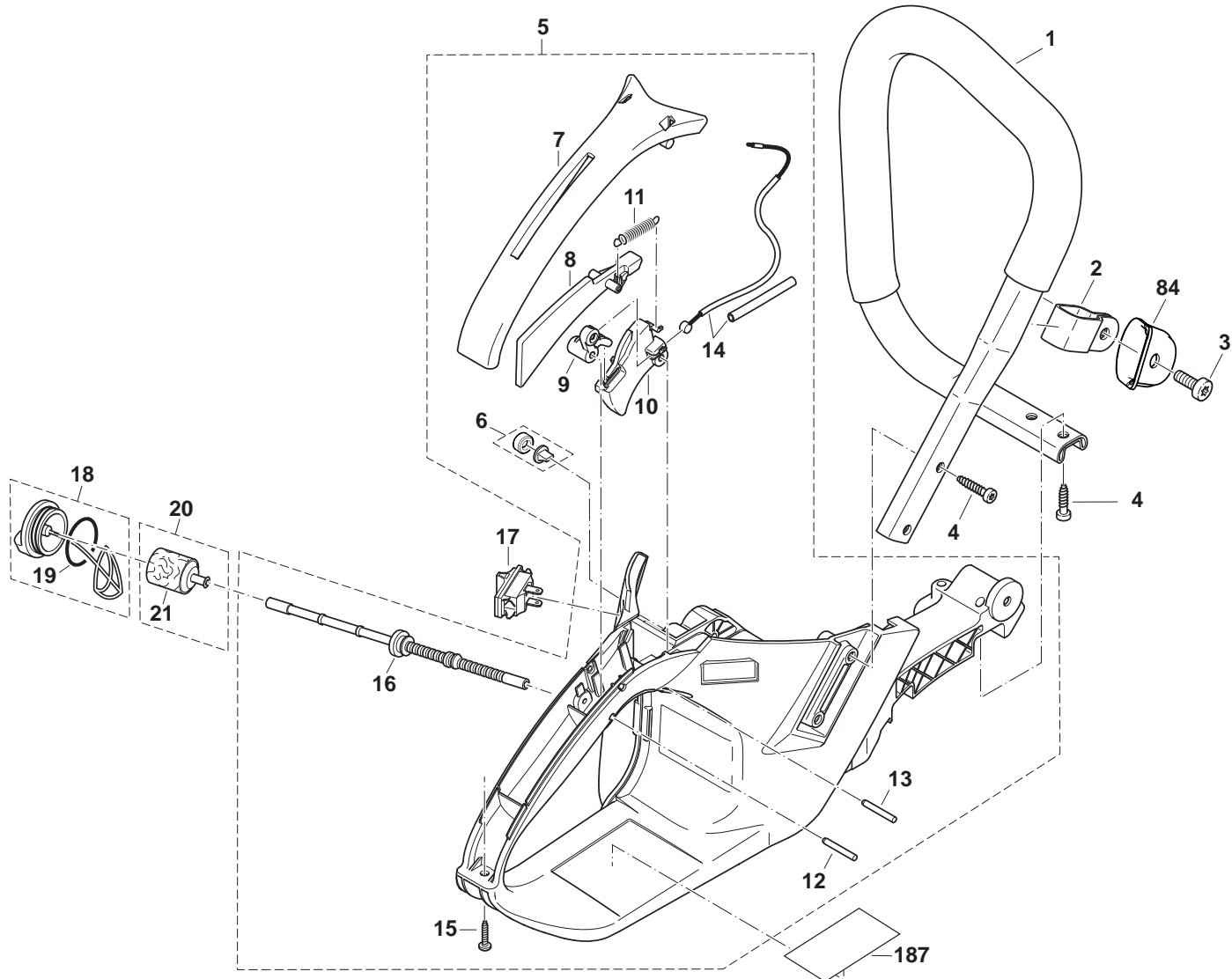

PS-630, PS-6400, PS-7300, PS-7900, PS-6400 D, PS-7300 D, PS-7900 D, PS-6400 H, PS-7300 H, PS-7900 H, PS-6400 DH, PS-7300 DH, PS-7900 DH, PS-6400 , PS-7300 , PS-7900 , PS-6400 H , PS-7300 H , PS-7900 H

1

Kraftstofftank, Bügelgriff  
Fuel tank, tubular grip  
Réserv. carburant, poignée tubulaire  
Depósito de combustible, mango tubular

**DOLMAR**  
A member of the **Takita** Group

Seite / Page	Pos.	PS-630	PS-6400	PS-7300	PS-7900	PS-6400 D	PS-7300 D	PS-7900 D	PS-6400 H	PS-7300 H	PS-7900 H	PS-6400 DH	PS-7300 DH	PS-7900 DH	PS-6400 (USA)	PS-7300 (USA)	PS-7900 (USA)	PS-6400 H (USA)	PS-7300 H (USA)	PS-7900 H (USA)	Teil-Nr. Part No. No. de pièce No. de pieza	Hinweise Notes Renseign. Nota	Bezeichnung	Spezifikation Specification	Description	Désignation	Denominación
1	1	1	1	1	1	1	1	1							1	1	1				038 310 020		BÜGELGRIFF KPL.		TUBULAR HANDLE ASSY.	POIGNÉE TUBULAIRE CPL.	MANGO TUBULAR CPL.
1	2	1	1	1	1	1	1	1	1	1	1	1	1	1	1	1	1	1	1	1	038 310 061	TI 2002/07	SCHELLE		CLAMP	BRIDE DE FIXATION	ABRAZADERA
1	3	1	1	1	1	1	1	1	1	1	1	1	1	1	1	1	1	1	1	1	908 006 145		SCHRAUBE	M6x14	SCREW	VIS	TORNILLO
1	4	2	2	2	2	2	2	2	2	2	2	2	2	2	2	2	2	2	2	2	913 455 164		INNENSTERN SCHRAUBE	5,5X16	SCREW	VIS	TORNILLO
1	5	1	1	1	1	1	1	1							1	1	1				038 114 107		KRAFTSTOFFTANK KPL. ROT		TANK CPL. RED	RÉSERVOIR CPL. ROUGE	DEPÓSITO CPL. ROJO
1	6	1	1	1	1	1	1	1	1	1	1	1	1	1	1	1	1	1	1	1	957 114 061		BELÜFTUNGSVENTIL KPL.		AIR VALVE CPL.	SOUPAPE D'AERATION CPL.	VÁLVULA VENTILACION CPL.
1	8	1	1	1	1	1	1	1	1	1	1	1	1	1	1	1	1	1	1	1	038 117 020		SICHERHEITSSPERRTA STE		CATCH LEVER	LEVIER DE VERROUILLAGE	PALANCA TRINCADA
1	7	1	1	1	1	1	1	1	1	1	1	1	1	1	1	1	1	1	1	1	038 114 031		HANDSCHALE ROT		GRIP PLATE RED	PLAQUE DE POIGNÉE ROUGE	CAPA DE MANGO ROJO
1	9	1	1	1	1	1	1	1	1	1	1	1	1	1	1	1	1	1	1	1	038 117 030		UMLENKHEBEL		ROCKER	LEVIER DE RENVOI	PALANCA DE CAMBIO
1	10	1	1	1	1	1	1	1	1	1	1	1	1	1	1	1	1	1	1	1	038 117 010		GASHEBEL		THROTTLE LEVER	LEVIER D'ACCÉLÉRATION	ACELERADOR
1	11	1	1	1	1	1	1	1	1	1	1	1	1	1	1	1	1	1	1	1	038 117 050		ZUGFEDER		SPRING	RESSORT	RESORTE
1	12	1	1	1	1	1	1	1	1	1	1	1	1	1	1	1	1	1	1	1	935 930 240		ZYLINDERSTIFT	3x24	CYLINDRICAL PIN	GOUPILLE CYL.	PRISIONERO
1	14	1	1	1	1	1	1	1	1	1	1	1	1	1	1	1	1	1	1	1	010 117 040		BOWDENZUG KPL.		BOWDEN CABLE	CÂBLE DE COMMANDE	TRANSMIS. FLEXIBLE BOWDEN
1	13	1	1	1	1	1	1	1	1	1	1	1	1	1	1	1	1	1	1	1	935 930 280		ZYLINDERSTIFT	ø 3x28	CYLINDRICAL PIN	GOUPILLE CYLINDRIQUE	PRISIONERO
1	15	1	1	1	1	1	1	1	1	1	1	1	1	1	1	1	1	1	1	1	913 340 204		INNENSTERN-SCHLITZ SCHRAUBE	4x20	SCREW	VIS	TORNILLO
1	16	1	1	1	1	1	1	1	1	1	1	1	1	1	1	1	1	1	1	1	038 114 051		KRAFTSTOFFLEITUNG		FUEL LINE	CONDUITE CARB.	TUBO COMB.
1	17	1	1	1	1	1	1	1	1	1	1	1	1	1	1	1	1	1	1	1	975 001 240		KURZSCHLUßSCHALTE R		SHORT-CIRCUIT SWITCH	INTERRUPTEUR COURT-CIRCUIT	INTERRUPTOR CORTO CIRCUITE
1	18	1	1	1	1	1	1	1	1	1	1	1	1	1	1	1	1	1	1	1	010 114 050		TANKVERSCHLUß KPL. (KRAFTST.)		TANK CAP ASSY. (FUEL)	BOUCHON RÉSERV. CPL. (CARB.)	CIERRE DE DEPÓSITO CPL.
1	19	1	1	1	1	1	1	1	1	1	1	1	1	1	1	1	1	1	1	1	963 228 030		O-RING	ø 28x3	PACKING RING	BAGUE-JOINT	ANILLO DE GUARNICIÓN
1	20	1	1	1	1	1	1	1	1	1	1	1	1	1	1	1	1	1	1	1	963 601 121		SAUGKOPF KPL.		SUCTION HEAD	TÊTE D'ASPIRATION	CABEZA DE ASPIRACIÓN
1	21	1	1	1	1	1	1	1	1	1	1	1	1	1	1	1	1	1	1	1	963 601 240		FILZFILTER		FELT	FEUTRE	FIELTRO
1	84	1	1	1	1	1	1	1	1	1	1	1	1	1	1	1	1	1	1	1	038 310 070		FEDERANSCHLAG		SPRING LIMITER	RESSORT DE BUTEE	MUELLE DE TOPE
1	85														1	1	1				038 310 110	USA	RUNDUMBÜGELGRIFF KPL.		WRAP AROUND HANDLE ASSY.	POIGNÉE CIRCULAIRE CPL.	MANGO CIRCULAR CPL.
1	188	2	2	2	2	2	2	2	2	2	2	2	2	2	2	2	2	2	2	2	913 455 204		SCHRAUBE	5,5x20	SCREW	VIS	TORNILLO

PS-630, PS-6400, PS-7300, PS-7900, PS-6400 D, PS-7300 D, PS-7900 D, PS-6400 H, PS-7300 H, PS-7900 H, PS-6400 DH, PS-7300 DH, PS-7900 DH, PS-6400 , PS-7300 , PS-7900 , PS-6400 H , PS-7300 H , PS-7900 H

2

Abdeckhaube, Luftfilter, Schalldämpfer  
 Hood, air filter, muffler  
 Capot protecteur, filtre à air, pot d'échappement  
 Cubierta protectora, filtro de aire, silencioso

**DOLMAR**  
 A member of the *Trakita* Group

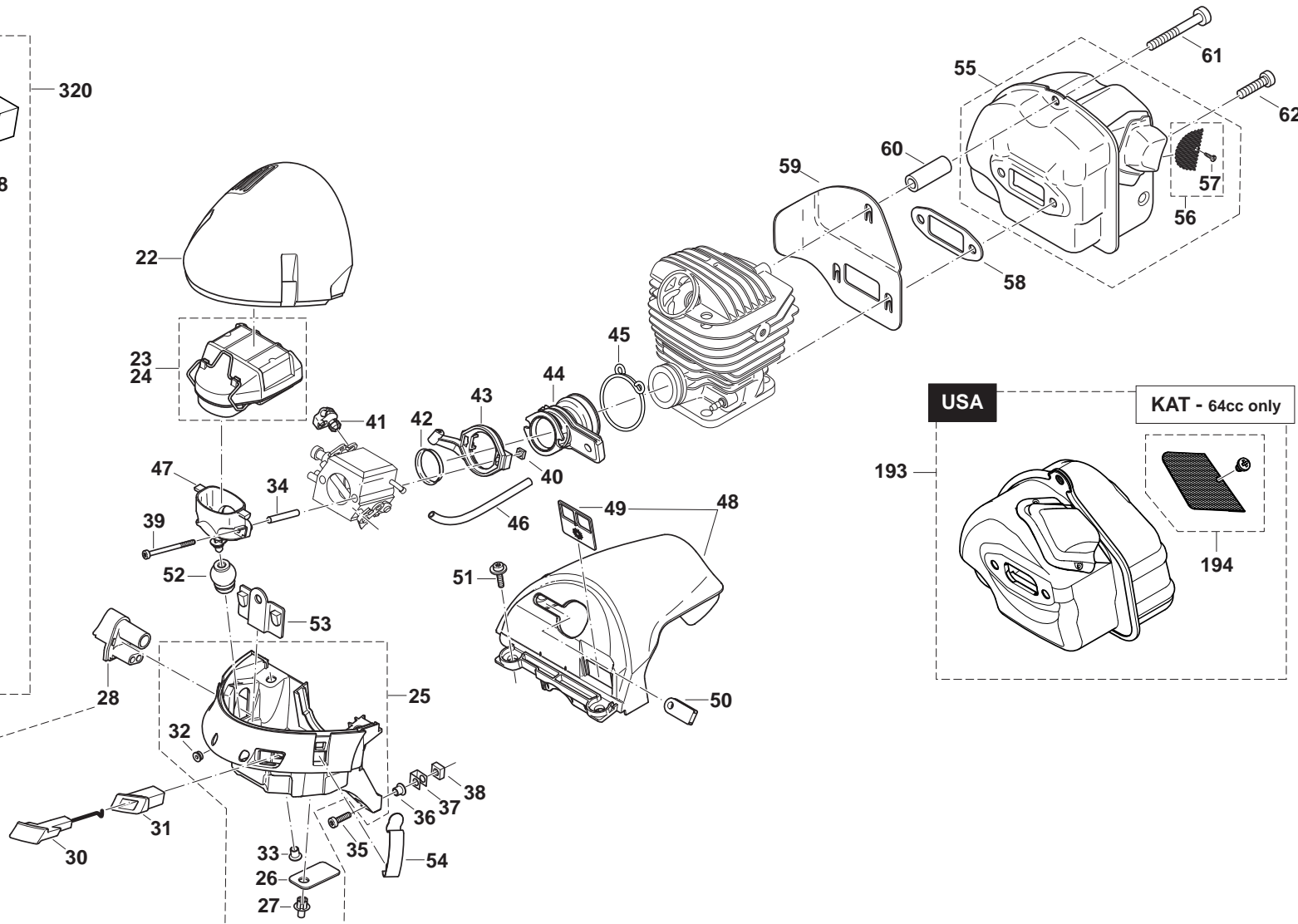
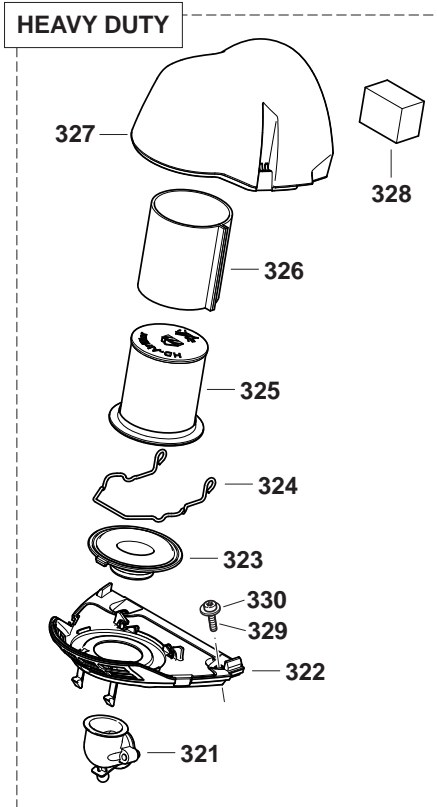

Maschinen älterer Bauart  
 Previous models  
 Machines d'ancienne production  
 Máquinas de fabricación antigua

29

PS-630, PS-6400, PS-7300, PS-7900, PS-6400 D, PS-7300 D, PS-7900 D, PS-6400 H, PS-7300 H, PS-7900 H, PS-6400 DH, PS-7300 DH, PS-7900 DH, PS-6400 , PS-7300 , PS-7900 , PS-6400 H , PS-7300 H , PS-7900 H

2

Abdeckhaube, Luftfilter, Schalldämpfer  
Hood, air filter, muffler  
Capot protecteur, filtre à air, pot d'échappement  
Cubierta protectora, filtro de aire, silencioso

**DOLMAR**  
A member of the **Takita** Group

Seite / Page	Pos.	PS-630	PS-6400	PS-7300	PS-7900	PS-6400 D	PS-7300 D	PS-7900 D	PS-6400 H	PS-7300 H	PS-7900 H	PS-6400 DH	PS-7300 DH	PS-7900 DH	PS-6400 (USA)	PS-7300 (USA)	PS-7900 (USA)	PS-6400 H (USA)	PS-7300 H (USA)	PS-7900 H (USA)	Teil-Nr. Part No. No. de pièce No. de pieza	Hinweise Notes Renseign. Nota	Bezeichnung	Spezifikation Specification	Description	Désignation	Denominación
2	22	1	1	1	1	1	1	1	1	1	1	1	1	1							038 118 022	RUS	DECKEL ROT		COVER RED	CAPOT ROUGE	CUBIERTA ROJO
2	22		1	1	1	1	1	1	1	1	1	1	1	1	1	1	1	1	1	1	038 118 222	USA	DECKEL SCHWARZ		COVER BLACK	CAPOT NOIR	CUBIERTA NEGRO
2	23	1	1	1	1	1	1	1	1	1	1	1	1	1	1	1	1	1	1	1	038 173 101		LUFTFILTER KPL.	VLIES	AIR FILTER CPL.	FILTRE Á AIR CPL.	FILTRO DE AIRE CPL.
2	24	1	1	1	1	1	1	1	1	1	1	1	1	1	1	1	1	1	1	1	038 173 011		LUFTFILTER KPL.	NYLON	AIR FILTER CPL.	FILTRE Á AIR CPL.	FILTRO DE AIRE CPL.
2	24	1	1	1	1	1	1	1	1	1	1	1	1	1	1	1	1	1	1	1	038 173 080	I, P	LUFTFILTER KPL.	NYLON 0,05 MM	AIR FILTER CPL.	FILTRE Á AIR CPL.	FILTRO DE AIRE CPL.
2	25	1	1	1	1	1	1	1	1	1	1	1	1	1	1	1	1	1	1	1	038 118 170		BODEN ROT		BOTTOM RED	FOND ROUGE	FONDO ROJO
2	26	2	2	2	2	2	2	2	2	2	2	2	2	2	2	2	2	2	2	2	038 118 110		GUMMIKLAPPE		RUBBER FLAP	CLAPET CAOUTCHOUC	VÁLVULA DE GOMA
2	27	2	2	2	2	2	2	2	2	2	2	2	2	2	2	2	2	2	2	2	938 650 062		SPREIZNIET		RIVET	RIVET	REMACHE
2	28	1	1	1	1	1	1	1	1	1	1	1	1	1	1	1	1	1	1	1	038 118 082		EINSTELLFÜHRUNG		ADJUSTING GUIDE	GUIDAGE D' AJUSTAGE	GUÍA DE AJUSTE
2	29	1	1	1	1	1	1	1	1	1	1	1	1	1	1	1	1	1	1	1	038 118 081	=> 2009-09	EINSTELLFÜHRUNG		ADJUSTING GUIDE	GUIDAGE D' AJUSTAGE	GUÍA DE AJUSTE
2	30	1	1	1	1	1	1	1	1	1	1	1	1	1	1	1	1	1	1	1	038 155 051		CHOKESTANGE		CHOKE SHAFT	LEVIER DE STARTER	PALANCA ESTRANGUL.AIRE
2	31	1	1	1	1	1	1	1	1	1	1	1	1	1	1	1	1	1	1	1	038 155 020		CHOKEFÜHRUNG		CHOKE GUIDE	GAINE STARTER	GUÍA DEL STARTER
2	32	1	1	1	1	1	1	1	1	1	1	1	1	1	1	1	1	1	1	1	038 118 300	2007-10-18 =>	GUMMITÜLLE		RUBBER BUSH	GAINE CAOUTCHOUC	BOQUILLA DE CAUCHO
2	32	1	1	1	1	1	1	1	1	1	1	1	1	1	1	1	1	1	1	1	965 401 020	=> 2007-10-18	GUMMITÜLLE		RUBBER BUSH	GAINE CAOUTCHOUC	BOQUILLA DE CAUCHO
2	33	2	2	2	2	2	2	2	2	2	2	2	2	2	2	2	2	2	2	2	001 118 100		BUCHSE		BUSHING	DOUILLE	CASQUILLO
2	34	2	2	2	2	2	2	2	2	2	2	2	2	2	2	2	2	2	2	2	038 155 060		DISTANZROHR	30 mm	SPACER	DOUILLE DE DISTANCE	CASQUILLO SEPARADOR
2	35	2	2	2	2	2	2	2	2	2	2	2	2	2	2	2	2	2	2	2	908 005 205		INNENSTERN SCHRAUBE	M5x20	SCREW	VIS	TORNILLO
2	36	2	2	2	2	2	2	2	2	2	2	2	2	2	2	2	2	2	2	2	001 118 100		BUCHSE		BUSHING	DOUILLE	CASQUILLO
2	37	2	2	2	2	2	2	2	2	2	2	2	2	2	2	2	2	2	2	2	038 111 050		KLAMMER		CLIP	AGRAFE	GRAPA
2	38	2	2	2	2	2	2	2	2	2	2	2	2	2	2	2	2	2	2	2	038 111 060		4KT-MUTTER	M5, SW10	SQUARE NUT	ECROU CARRÉ	TUERCA CUADR.
2	39	2	2	2	2	2	2	2	2	2	2	2	2	2	2	2	2	2	2	2	908 204 555		INNENSTERN-SCHRAUBE	M4x55	SCREW	VIS	TORNILLO
2	40	2	2	2	2	2	2	2	2	2	2	2	2	2	2	2	2	2	2	2	921 804 004		4KT-MUTTER	M4	SQUARE NUT	ECROU CARRÉ	TUERCA CUADR.
2	41	1	1	1	1	1	1	1	1	1	1	1	1	1	1	1	1	1	1	1	038 155 012		AUFNAHME FÜR BOWDENZUG		RETAINING CLIP	SUPPORT DU DISPOS. DE TIRAGE	TRACCIÓN BOWDEN, SOPORTE
2	42	1	1	1	1	1	1	1	1	1	1	1	1	1	1	1	1	1	1	1	038 131 031		EINSATZ FÜR ANSAUGSCHLAUCH		INSERT FOR SUCTION HOSE	PIÈCE P. TUYAU D' ASPIRATION	SUPLEMENTO P. TUBO DE ASP.
2	43	1	1	1	1	1	1	1	1	1	1	1	1	1	1	1	1	1	1	1	038 171 041		FLANSCHRING		FLANGE	BRIDE	BRIDA
2	44	1	1	1	1	1	1	1	1	1	1	1	1	1	1	1	1	1	1	1	038 131 011		ANSAUGSCHLAUCH		SUCTION HOSE	TUYAU D' ASPIRATION	TUBO DE ASPIRACIÓN
2	45	1	1	1	1	1	1	1	1	1	1	1	1	1	1	1	1	1	1	1	038 131 070		FEDERSCHELLE		HOSE CLIP	COLLIER DE SERRAGE	ABRAZADERA
2	46	m	m	m	m	m	m	m	m	m	m	m	m	m	m	m	m	m	m	m	965 452 380		SCHLAUCH	65 mm	TUBE	GAINE	TUBO

PS-630, PS-6400, PS-7300, PS-7900, PS-6400 D, PS-7300 D, PS-7900 D, PS-6400 H, PS-7300 H, PS-7900 H, PS-6400 DH, PS-7300 DH, PS-7900 DH, PS-6400 , PS-7300 , PS-7900 , PS-6400 H , PS-7300 H , PS-7900 H

2

Abdeckhaube, Luftfilter, Schalldämpfer  
 Hood, air filter, muffler  
 Capot protecteur, filtre à air, pot d'échappement  
 Cubierta protectora, filtro de aire, silencioso

**DOLMAR**  
 A member of the *Trakita* Group

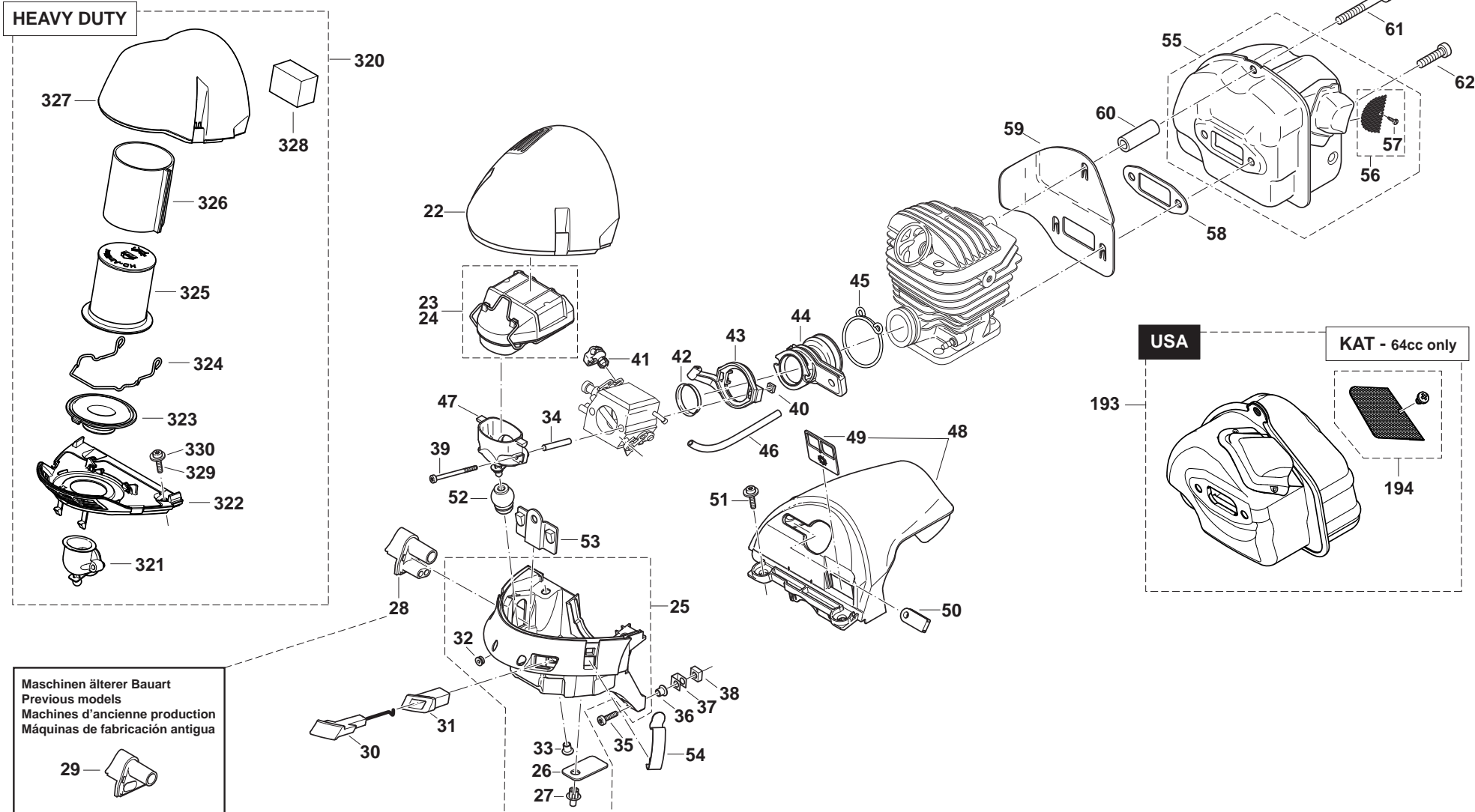

PS-630, PS-6400, PS-7300, PS-7900, PS-6400 D, PS-7300 D, PS-7900 D, PS-6400 H, PS-7300 H, PS-7900 H, PS-6400 DH, PS-7300 DH, PS-7900 DH, PS-6400 , PS-7300 , PS-7900 , PS-6400 H , PS-7300 H , PS-7900 H

2

Abdeckhaube, Luftfilter, Schalldämpfer  
Hood, air filter, muffler  
Capot protecteur, filtre à air, pot d' échappement  
Cubierta protectora, filtro de aire, silencioso

**DOLMAR**  
A member of the **Takita** Group

Seite / Page	Pos.	PS-630	PS-6400	PS-7300	PS-7900	PS-6400 D	PS-7300 D	PS-7900 D	PS-6400 H	PS-7300 H	PS-7900 H	PS-6400 DH	PS-7300 DH	PS-7900 DH	PS-6400 (USA)	PS-7300 (USA)	PS-7900 (USA)	PS-6400 H (USA)	PS-7300 H (USA)	PS-7900 H (USA)	Teil-Nr. Part No. No. de pièce No. de pieza	Hinweise Notes Renseign. Nota	Bezeichnung	Spezifikation Specification	Description	Désignation	Denominación	
2	47	1	1	1	1	1	1	1	1	1	1	1	1	1	1	1	1	1	1	1	1	038 171 011		ANSAUGKRÜMMER		CONNECTING MUFF	MANCHON DE JONCTION	MANGUITO DE CONEXIÓN
2	48		1	1	1				1	1	1											038 118 012	RUS	ABDECKHAUBE ROT		HOOD CPL. RED	CAPOT PROT. CPL. ROUGE	TAPA PROT. CPL. ROJO
2	48	1				1	1	1				1	1	1								038 118 091	RUS	ABDECKHAUBE ROT	DECO	HOOD CPL. RED	CAPOT PROT. CPL. ROUGE	TAPA PROT. CPL. ROJO
2	48		1	1	1				1	1	1											038 118 212	USA	ABDECKHAUBE SCHWARZ		HOOD CPL. BLACK	CAPOT PROT. CPL. NOIR	TAPA PROT. CPL. NEGRO
2	48					1	1	1				1	1	1	1	1	1	1	1	1	1	038 118 291	USA	ABDECKHAUBE SCHWARZ	DECO	HOOD CPL. BLACK	CAPOT PROT. CPL. NOIR	TAPA PROT. CPL. NEGRO
2	49	1	1	1	1	1	1	1	1	1	1	1	1	1	1	1	1	1	1	1	1	038 118 140		WINTERSTOPFEN		INSERT	PIÈCE D' INSERTION	PIEZA DE CIERRE
2	50	1	1	1	1	1	1	1	1	1	1	1	1	1	1	1	1	1	1	1	1	038 118 130		KABELDURCHFÜHRUNG		CABLE GUIDE	PASSAGE DU CÂBLE	BOQUILLA DE PASO PARA CABLES
2	51	2	2	2	2	2	2	2	2	2	2	2	2	2	2	2	2	2	2	2	2	917 105 205		INNENSTERN-KOMBISCHRAUBE	M5X20	SCREW	VIS	TORNILLO
2	52	1	1	1	1	1	1	1	1	1	1	1	1	1	1	1	1	1	1	1	1	038 171 030		HALTERUNG FÜR ANSAUGKRÜMMER		HOLDER	SUPPORT	SOPORTE
2	53	1	1	1	1	1	1	1	1	1	1	1	1	1	1	1	1	1	1	1	1	038 118 100		STOPFEN		PLUG	OBTURATION	TAPABOCADOS
2	54	2	2	2	2	2	2	2	2	2	2	2	2	2	2	2	2	2	2	2	2	038 118 071		STAHLKLAMMER		STEELCLIP	AGRAFE	PINZA DE ACERO
2	55	1	1	1	1	1	1	1	1	1	1	1	1	1	1	1	1	1	1	1	1	038 174 200		SCHALLDÄMPFER		MUFFLER	POT D' ÉCHAPPEMENT	SILENCIADOR
2	56	1	1	1	1	1	1	1	1	1	1	1	1	1	1	1	1	1	1	1	1	038 174 040	USA, AUS	FUNKENSCHUTZSIEBKPL.		SPARK ARRESTER SCREEN CPL.	TAMIS CPL.	TAMIZ CPL.
2	57	1	1	1	1	1	1	1	1	1	1	1	1	1	1	1	1	1	1	1	1	915 035 120	USA, AUS	SCHRAUBE		SCREW	VIS	TORNILLO
2	58	1	1	1	1	1	1	1	1	1	1	1	1	1	1	1	1	1	1	1	1	965 531 131		DICHTUNG		GASKET	JOINT	JUNTA
2	59	1	1	1	1	1	1	1	1	1	1	1	1	1	1	1	1	1	1	1	1	038 174 021		ABSCHIRMBLECH		COOLING PLATE	TÔLE DE PROTECTION	CHAPA DEFLECTORA
2	60	1	1	1	1	1	1	1	1	1	1	1	1	1	1	1	1	1	1	1	1	038 174 030		ZWISCHENSTÜCK		CONNECTING LINK	INTERMEDIARE	PIEZA INTERMEDIARIA
2	61	1	1	1	1	1	1	1	1	1	1	1	1	1	1	1	1	1	1	1	1	908 305 405		INNENSTERN-SCHRAUBE	M5x20x40	SCREW	VIS	TORNILLO
2	62	2	2	2	2	2	2	2	2	2	2	2	2	2	2	2	2	2	2	2	2	908 405 205		INNENSTERN-SCHRAUBE	M5x20	SCREW	VIS	TORNILLO
2	193														1							038 174 300	USA	SCHALLDÄMPFER	KAT	MUFFLER	POT D' ÉCHAPPEMENT	SILENCIADOR
2	320	1	1	1	1	1	1	1	1	1	1	1	1	1	1	1	1	1	1	1	1	957 173 400	ACC.	LUFTFILTER	HEAVY DUTY	AIR FILTER	FILTRE À AIR	FILTRO DE AIRE
2	321	1	1	1	1	1	1	1	1	1	1	1	1	1	1	1	1	1	1	1	1	038 171 050		ANSAUGKRÜMMER	HEAVY DUTY	CONNECTING MUFF	MANCHON DE JONCTION	MANGUITO DE CONEXIÓN
2	322	1	1	1	1	1	1	1	1	1	1	1	1	1	1	1	1	1	1	1	1	038 118 460		ZWISCHENBODEN		INTERMEDIATE BOTTOM	FOND	PALIER INTERMÉDIAIRE
2	323	1	1	1	1	1	1	1	1	1	1	1	1	1	1	1	1	1	1	1	1	038 118 490		BALG		BELLOWS	BELLOWS	PIEL
2	324	1	1	1	1	1	1	1	1	1	1	1	1	1	1	1	1	1	1	1	1	038 118 450		BÜGELKLAMMER		CLIP FOR BOW	CRAMPON	GRAPA

PS-630, PS-6400, PS-7300, PS-7900, PS-6400 D, PS-7300 D, PS-7900 D, PS-6400 H, PS-7300 H, PS-7900 H, PS-6400 DH, PS-7300 DH, PS-7900 DH, PS-6400 , PS-7300 , PS-7900 , PS-6400 H , PS-7300 H , PS-7900 H

2

Abdeckhaube, Luftfilter, Schalldämpfer  
 Hood, air filter, muffler  
 Capot protecteur, filtre à air, pot d'échappement  
 Cubierta protectora, filtro de aire, silencioso

**DOLMAR**  
 A member of the *Trakita* Group

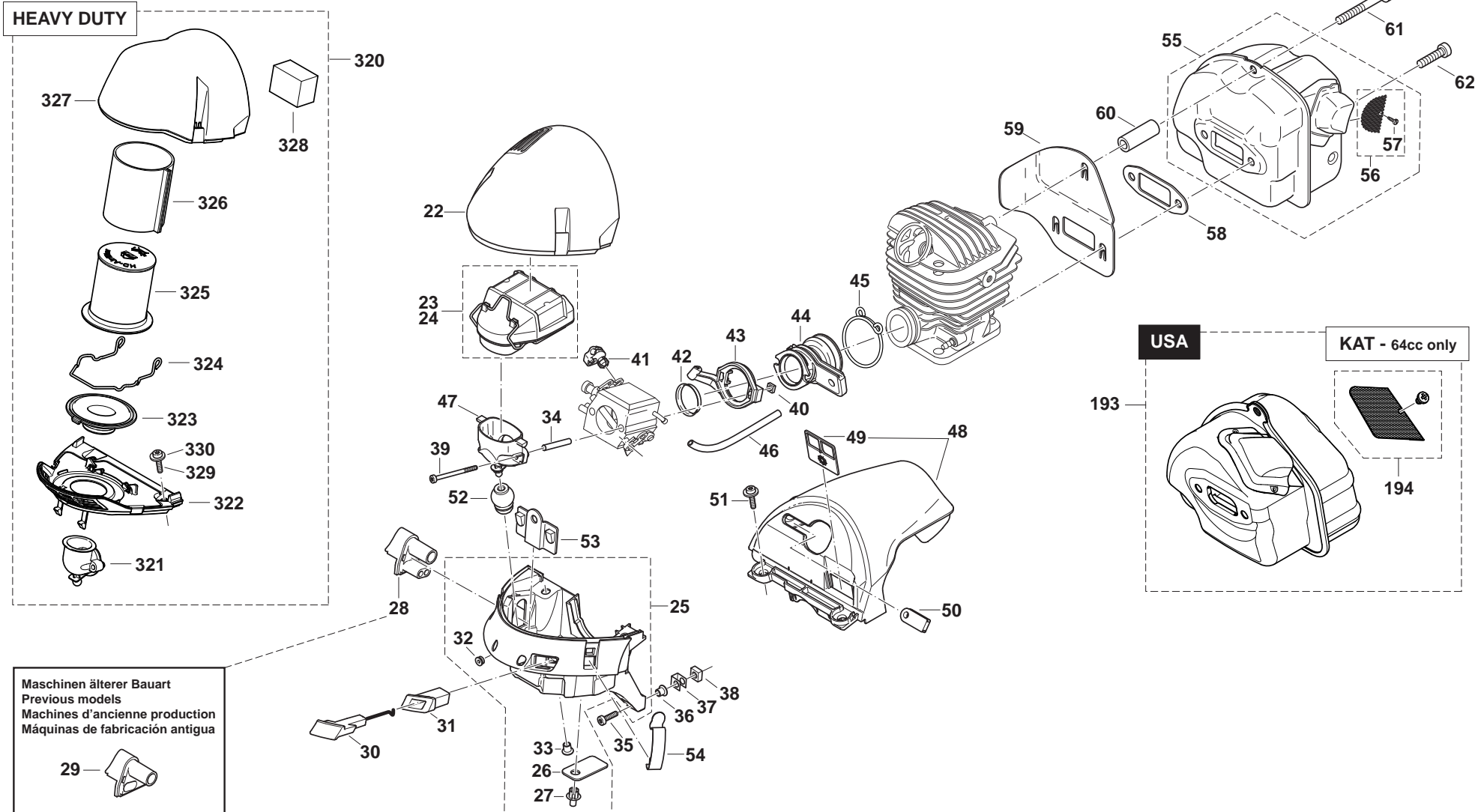



PS-630, PS-6400, PS-7300, PS-7900, PS-6400 D, PS-7300 D, PS-7900 D, PS-6400 H, PS-7300 H, PS-7900 H, PS-6400 DH, PS-7300 DH, PS-7900 DH, PS-6400 , PS-7300 , PS-7900 , PS-6400 H , PS-7300 H , PS-7900 H

2

Abdeckhaube, Luftfilter, Schalldämpfer  
Hood, air filter, muffler  
Capot protecteur, filtre à air, pot d' échappement  
Cubierta protectora, filtro de aire, silencioso

**DOLMAR**



A member of the **Takita** Group

Seite / Page	Pos.	PS-630	PS-6400	PS-7300	PS-7900	PS-6400 D	PS-7300 D	PS-7900 D	PS-6400 H	PS-7300 H	PS-7900 H	PS-6400 DH	PS-7300 DH	PS-7900 DH	PS-6400 (USA)	PS-7300 (USA)	PS-7900 (USA)	PS-6400 H (USA)	PS-7300 H (USA)	PS-7900 H (USA)	Teil-Nr. Part No. No. de pièce No. de pieza	Hinweise Notes Renseign. Nota	Bezeichnung	Spezifikation Specification	Description	Désignation	Denominación
2	325	1	1	1	1	1	1	1	1	1	1	1	1	1	1	1	1	1	1	1	038 173 310		LUFTFILTERPATRONE		AIR-FILTER CARTRIDGE	FILTRE A AIR DE CARTOUCHE	FILTRO DE AIRE DEL CARTUCHO
2	326	1	1	1	1	1	1	1	1	1	1	1	1	1	1	1	1	1	1	1	038 173 350		VORFILTERPATRONE		PRE-FILTER	PRE-FILTER	FILTRO
2	327	1	1	1	1	1	1	1	1	1	1	1	1	1	1	1	1	1	1	1	038 118 410		DECKEL	BLACK, HD	COVER	COUVERCLE	TAPA
2	328	1	1	1	1	1	1	1	1	1	1	1	1	1	1	1	1	1	1	1	038 173 370		VORFILTER	S/W	PRE-FILTER	PREFILTRE	PRIMER FILTRO
2	329	2	2	2	2	2	2	2	2	2	2	2	2	2	2	2	2	2	2	2	908 405 255		INNENSTERN-SCHRA UBE	M5x25	SCREW	VIS	TORNILLO
2	330	2	2	2	2	2	2	2	2	2	2	2	2	2	2	2	2	2	2	2	924 805 310		SCHEIBE	ø5,3/15x1	DISC	DISQUE	DISCO DE TOPE

PS-630, PS-6400, PS-7300, PS-7900, PS-6400 D, PS-7300 D, PS-7900 D, PS-6400 H, PS-7300 H, PS-7900 H, PS-6400 DH, PS-7300 DH, PS-7900 DH, PS-6400 , PS-7300 , PS-7900 , PS-6400 H , PS-7300 H , PS-7900 H

3

Zylinder, Kurbelgehäuse  
Cylinder, crankcase  
Cylindre, carter-vilebrequin  
Cilindro, cárter cigüeñal

**DOLMAR**



A member of the **Takita** Group

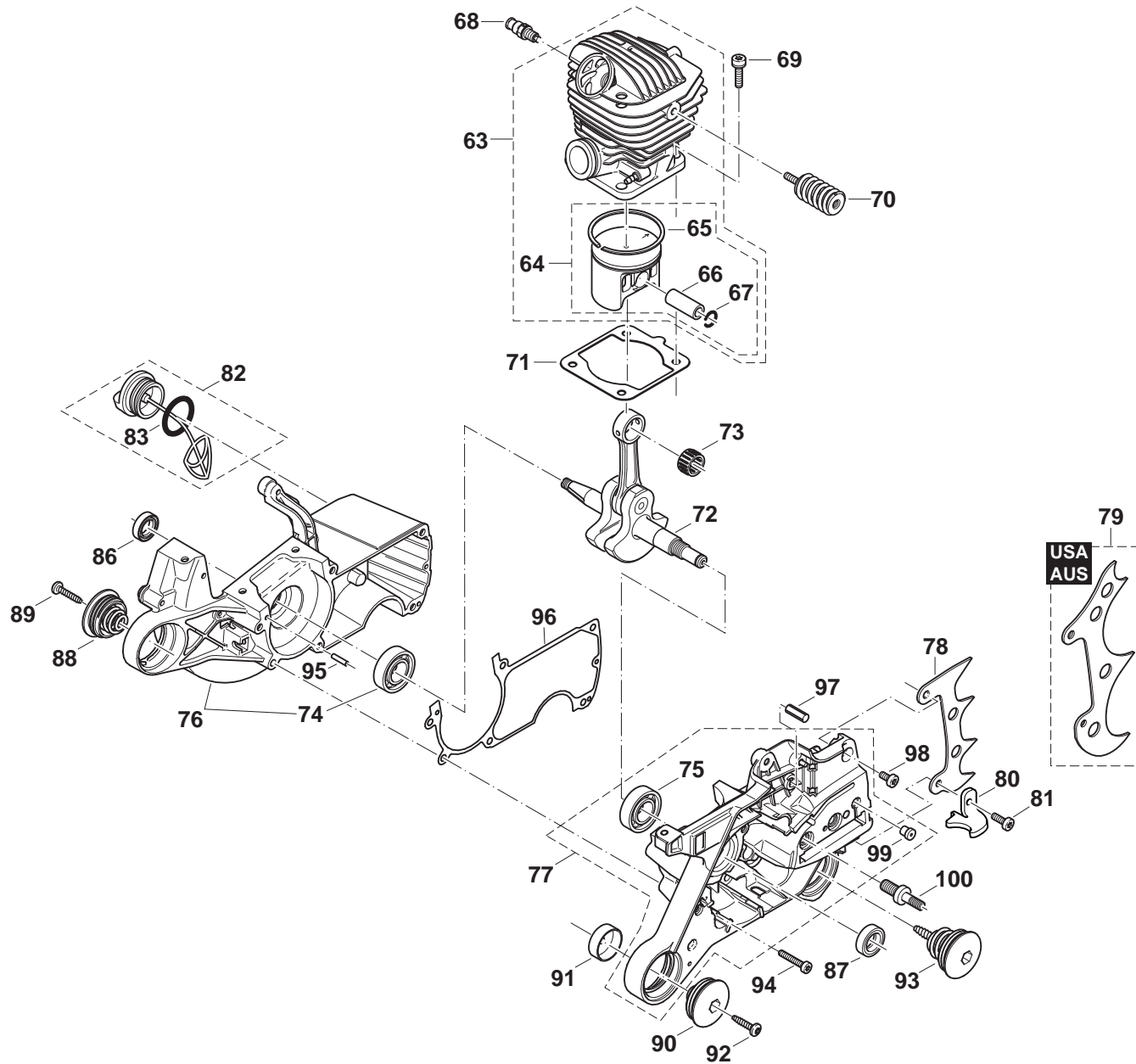

PS-630, PS-6400, PS-7300, PS-7900, PS-6400 D, PS-7300 D, PS-7900 D, PS-6400 H, PS-7300 H, PS-7900 H, PS-6400 DH, PS-7300 DH, PS-7900 DH, PS-6400 , PS-7300 , PS-7900 , PS-6400 H , PS-7300 H , PS-7900 H

3

Zylinder, Kurbelgehäuse  
Cylinder, crankcase  
Cylindre, carter-vilebrequin  
Cilindro, cárter cigüeñal

**DOLMAR**  
A member of the **Takita** Group

Seite / Page	Pos.	PS-630	PS-6400	PS-7300	PS-7900	PS-6400 D	PS-7300 D	PS-7900 D	PS-6400 H	PS-7300 H	PS-7900 H	PS-6400 DH	PS-7300 DH	PS-7900 DH	PS-6400 (USA)	PS-7300 (USA)	PS-7900 (USA)	PS-6400 H (USA)	PS-7300 H (USA)	PS-7900 H (USA)	Teil-Nr. Part No. No. de pièce No. de pieza	Hinweise Notes Renseign. Nota	Bezeichnung	Spezifikation Specification	Description	Désignation	Denominación
3	63		1						1												040 130 023	TI 2002-08	ZYLINDER / KOLBEN KPL.	D=47	CYLINDER / PISTON CPL.	CYLINDRE ET PISTON CPL.	CILINDRO CON PISTÓN CPL.
3	63			1						1											039 130 021	TI 2002-08	ZYLINDER / KOLBEN KPL.	D=50	CYLINDER / PISTON CPL.	CYLINDRE ET PISTON CPL.	CILINDRO CON PISTÓN CPL.
3	63				1						1										038 130 021	TI 2002-08	ZYLINDER / KOLBEN KPL.	D=52	CYLINDER / PISTON CPL.	CYLINDRE ET PISTON CPL.	CILINDRO CON PISTÓN CPL.
3	63	1				1						1						1			040 130 033	TI 2002-08	ZYLINDER / KOLBEN KPL.	D=47 DECO	CYLINDER / PISTON CPL.	CYLINDRE ET PISTON CPL.	CILINDRO CON PISTÓN CPL.
3	63						1						1						1		039 130 031	TI 2002-08	ZYLINDER / KOLBEN KPL.	D=50 DECO	CYLINDER / PISTON CPL.	CYLINDRE ET PISTON CPL.	CILINDRO CON PISTÓN CPL.
3	63							1						1					1		038 130 031	TI 2002-08	ZYLINDER / KOLBEN KPL.	D=52 DECO	CYLINDER / PISTON CPL.	CYLINDRE ET PISTON CPL.	CILINDRO CON PISTÓN CPL.
3	64	1	1			1			1			1						1			325 132 033		KOLBEN A KPL.	ø 47	PISTON CPL.	PISTON CPL.	PISTÓN CPL.
3	64			1		1			1			1							1		394 132 112		KOLBEN AB KPL.	ø 50	PISTON CPL.	PISTON CPL.	PISTÓN CPL.
3	64				1		1			1		1							1		038 132 000		KOLBEN KPL.	D=52	PISTON CPL.	PISTON CPL.	PISTÓN CPL.
3	65	1	1			1			1			1									325 132 050		KOLBENRING	ø 47	PISTON RING	SEGMENT DE PISTON	SEGMENTO DE PISTÓN
3	65			1		1				1		1									394 132 020		KOLBENRING	ø 50	PISTON RING	SEGMENT DE PISTON	SEGMENTO DE PISTÓN
3	65				1		1			1		1							1		038 132 020		KOLBENRING	ø 52	PISTON RING	SEGMENT DE PISTON	SEGMENTO DE PISTÓN
3	66	1	1	1		1	1		1	1		1	1					1	1		119 132 030		KOLBENBOLZEN		PISTON PIN	AXE DE PISTON	PERNO DE PISTÓN
3	66				1		1			1		1								1	038 132 040		KOLBENBOLZEN		PISTON PIN	AXE DE PISTON	PERNO DE PISTÓN
3	67	2	2	2	2	2	2	2	2	2	2	2	2	2	2	2	2	2	2	2	119 132 060		SPRENGRING	C12X1	SPRING RING	ANNEAU-RESSORT	ANILLO ELÁSTICO
3	68	1				1	1	1				1	1	1	1	1	1	1	1	1	001 131 150		DEKOMPRESSIVSVENTIL		VALVE	SOUPAPE	VÁLVULA
3	69	4	4	4	4	4	4	4	4	4	4	4	4	4	4	4	4	4	4	4	908 805 235		INNENSTERNSCHRAUBE MIT SPANNSCHEIBE	M5x23	SCREW	VIS	TORNILLO
3	70	1	1	1	1	1	1	1	1	1	1	1	1	1	1	1	1	1	1	1	038 114 152	TI 2002-07	FEDER MIT 2 GEWINDEINSÄTZEN		SPRING W. THREADED INSERT	RESSORT AVEC FILETAGE	MUELLE CON ROSCA
3	71	1	1	1	1	1	1	1	1	1	1	1	1	1	1	1	1	1	1	1	965 531 160		ZYLINDERFUßDICHTUNG, METALL		GASKET, METAL	JOINT, MÉTAL	JUNTA, METAL
3	72	1	1	1	1	1	1	1	1	1	1	1	1	1	1	1	1	1	1	1	038 120 021		KURBELWELLE KPL.		CRANKSHAFT CPL.	VILEBREQUIN CPL.	CIGÜEÑAL CPL.
3	73	1	1	1	1	1	1	1	1	1	1	1	1	1	1	1	1	1	1	1	962 210 019		NADELKÄFIG		NEEDLE CAGE	CAGE À AIGUILLES	JAULA DE AGUJAS
3	74	1	1	1	1	1	1	1	1	1	1	1	1	1	1	1	1	1	1	1	960 102 159		KUGELLAGER (EINKLEBEN)	6202	BALL BEARING (USE GLUE)	ROULEMENT À BILLES (À COLLER)	RODAM. DE BOLAS (A COLAR)
3	75	1	1	1	1	1	1	1	1	1	1	1	1	1	1	1	1	1	1	1	960 102 179		KUGELLAGER	6203 C4	BALL BEARING	ROULEMENT À BILLES	RODAMIENTO DE BOLAS
3	76	1	1	1	1	1	1	1							1	1	1				038 111 160		KURBELGEHÄUSE MS ROT		CRANKC. MAG. SIDE RED	CARTER-COTÉ MAGN. ROUGE	CÁRTER CIG. LADO MAG. ROJO
3	77	1	1	1	1	1	1	1	1	1	1	1	1	1	1	1	1	1	1	1	038 111 141		KURBELGEHÄUSE KS ROT		CRANKC. CLUTCH SIDE RED	CARTER-COTÉ EMBR. ROUGE	CÁRTER CIG. LADO EMBR. ROJO

PS-630, PS-6400, PS-7300, PS-7900, PS-6400 D, PS-7300 D, PS-7900 D, PS-6400 H, PS-7300 H, PS-7900 H, PS-6400 DH, PS-7300 DH, PS-7900 DH, PS-6400 , PS-7300 , PS-7900 , PS-6400 H , PS-7300 H , PS-7900 H

3

Zylinder, Kurbelgehäuse  
Cylinder, crankcase  
Cylindre, carter-vilebrequin  
Cilindro, cárter cigüeñal

**DOLMAR**

A member of the **Takita** Group

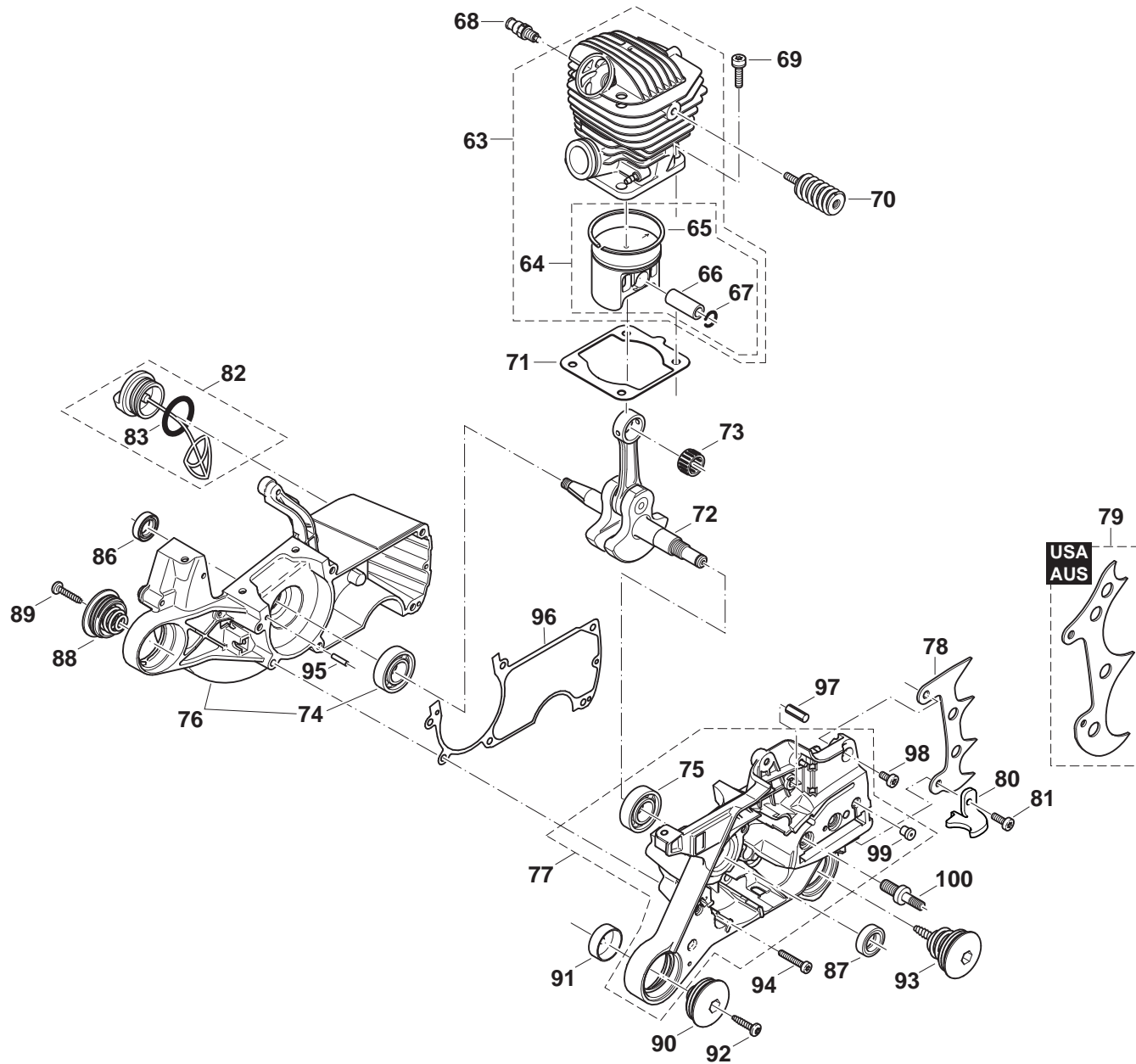

PS-630, PS-6400, PS-7300, PS-7900, PS-6400 D, PS-7300 D, PS-7900 D, PS-6400 H, PS-7300 H, PS-7900 H, PS-6400 DH, PS-7300 DH, PS-7900 DH, PS-6400 , PS-7300 , PS-7900 , PS-6400 H , PS-7300 H , PS-7900 H

3

Zylinder, Kurbelgehäuse  
Cylinder, crankcase  
Cylindre, carter-vilebrequin  
Cilindro, cárter cigüeñal

**DOLMAR**  
A member of the **Takita** Group

Seite / Page	Pos.	PS-630	PS-6400	PS-7300	PS-7900	PS-6400 D	PS-7300 D	PS-7900 D	PS-6400 H	PS-7300 H	PS-7900 H	PS-6400 DH	PS-7300 DH	PS-7900 DH	PS-6400 (USA)	PS-7300 (USA)	PS-7900 (USA)	PS-6400 H (USA)	PS-7300 H (USA)	PS-7900 H (USA)	Teil-Nr. Part No. No. de pièce No. de pieza	Hinweise Notes Renseign. Nota	Bezeichnung	Spezifikation Specification	Description	Désignation	Denominación
3	78	1	1	1	1	1	1	1	1	1	1	1	1	1	1	1	1	1	1	1	038 250 021		ZACKENLEISTE		SPIKE BAR	BARRE DENTÉE	BARRA DENTADA
3	79		1	1	1	1	1	1	1	1	1	1	1	1	1	1	1	1	1	1	038 250 201		ZACKENLEISTE	USA, AUS	SPIKE BAR	BARRE DENTÉE	BARRA DENTADA
3	80	1	1	1	1	1	1	1	1	1	1	1	1	1	1	1	1	1	1	1	038 111 171		KETTENFÄNGER		CHAIN CATCH	ARRÊTE-CHAÎNE	BULÓN DE RETENCIÓN
3	81	1	1	1	1	1	1	1	1	1	1	1	1	1	1	1	1	1	1	1	908 005 165		SCHRAUBE	M5x16	SCREW	VIS	TORNILLO
3	82	1	1	1	1	1	1	1	1	1	1	1	1	1	1	1	1	1	1	1	010 114 050		TANKVERSCHLUß KPL. (KRAFTST.)		TANK CAP ASSY. (FUEL)	BOUCHON RÉSERV. CPL. (CARB.)	CIERRE DE DEPÓSITO CPL.
3	83	1	1	1	1	1	1	1	1	1	1	1	1	1	1	1	1	1	1	1	963 228 030		O-RING	ø 28x3	PACKING RING	BAGUE-JOINT	ANILLO DE GUARNICIÓN
3	86	1	1	1	1	1	1	1	1	1	1	1	1	1	1	1	1	1	1	1	962 900 052		RADIALDICHRING	ø15/24x7	RADIAL RING	JOINT RADIAL	JUNTA RADIAL
3	87	1	1	1	1	1	1	1	1	1	1	1	1	1	1	1	1	1	1	1	962 900 061		RADIALDICHRING	17X28X5/4	RADIAL RING	JOINT RADIAL	ANILLO RADIAL
3	88	1	1	1	1	1	1	1	1	1	1	1	1	1	1	1	1	1	1	1	038 114 130		FEDER KPL. MIT KAPPE		SPRING CPL. WITH CAP	RESSORT CPL.	RESORTE CPL.
3	89	1	1	1	1	1	1	1	1	1	1	1	1	1	1	1	1	1	1	1	913 455 204		SCHRAUBE	5,5x20	SCREW	VIS	TORNILLO
3	90	1	1	1	1	1	1	1	1	1	1	1	1	1	1	1	1	1	1	1	038 114 130		FEDER KPL. MIT KAPPE		SPRING CPL. WITH CAP	RESSORT CPL.	RESORTE CPL.
3	91	1	1	1	1	1	1	1	1	1	1	1	1	1	1	1	1	1	1	1	038 114 190		TOPF		POT	CAPUCHON	POTE
3	92	1	1	1	1	1	1	1	1	1	1	1	1	1	1	1	1	1	1	1	913 455 204		SCHRAUBE	5,5x20	SCREW	VIS	TORNILLO
3	93	1	1	1	1	1	1	1	1	1	1	1	1	1	1	1	1	1	1	1	038 114 141		FEDER KPL. MIT KAPPE		SPRING CPL. WITH CAP	RESSORT CPL.	RESORTE CPL.
3	94	6	6	6	6	6	6	6	6	6	6	6	6	6	6	6	6	6	6	6	908 005 305		INNENSTERN-SCHRAUB E	M5x30	SCREW	VIS	TORNILLO
3	95	2	2	2	2	2	2	2	2	2	2	2	2	2	2	2	2	2	2	2	936 430 160		SPIRALSPANNSTIFT	3X16	CLAMPING PIN	GOUPILLE	PASADOR
3	96	1	1	1	1	1	1	1	1	1	1	1	1	1	1	1	1	1	1	1	038 111 042		KURBELGEHÄUSEDICHT UNG		GASKET	JOINT	JUNTA
3	97	1	1	1	1	1	1	1	1	1	1	1	1	1	1	1	1	1	1	1	934 660 250		KERBSTIFT	6x24	SLOTTED PIN	GOUPILLE FENDUE	CLAVIJA MUESCA
3	98	1	1	1	1	1	1	1	1	1	1	1	1	1	1	1	1	1	1	1	908 005 125		INNENSTERN-SCHRAUB E	M5x12	SCREW	VIS	TORNILLO
3	99	1	1	1	1	1	1	1	1	1	1	1	1	1	1	1	1	1	1	1	010 245 030		BELÜFTUNGSVENTIL		VENT VALVE	SOUPAPE D AERATION	VALVULA VENTILACION
3	100	2	2	2	2	2	2	2	2	2	2	2	2	2	2	2	2	2	2	2	038 232 010		BEFESTIGUNGSBOLZEN		BOLT	BOULON	BULÓN

PS-630, PS-6400, PS-7300, PS-7900, PS-6400 D, PS-7300 D, PS-7900 D, PS-6400 H, PS-7300 H, PS-7900 H, PS-6400 DH, PS-7300 DH, PS-7900 DH, PS-6400 , PS-7300 , PS-7900 , PS-6400 H , PS-7300 H , PS-7900 H

4

Zündelektronik, Anwerfvorrichtung  
Ignition electronics, starter  
Allumage électronique, dispositif de démarrage  
Bobina encendido, dispositivo de arranque

**DOLMAR**



A member of the **Takita** Group

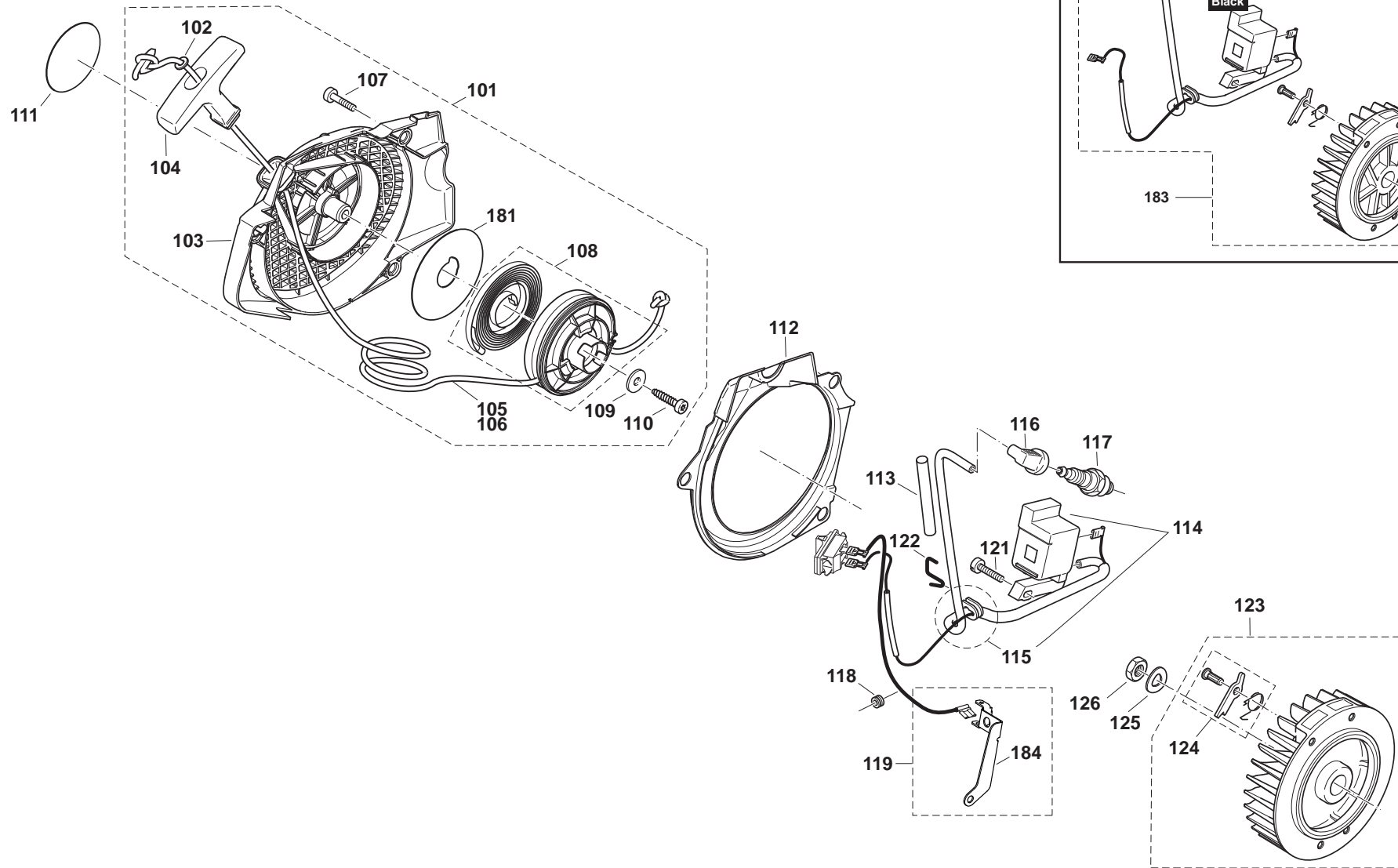

PS-630, PS-6400, PS-7300, PS-7900, PS-6400 D, PS-7300 D, PS-7900 D, PS-6400 H, PS-7300 H, PS-7900 H, PS-6400 DH, PS-7300 DH, PS-7900 DH, PS-6400 , PS-7300 , PS-7900 , PS-6400 H , PS-7300 H , PS-7900 H

4

Zündelektronik, Anwerfvorrichtung  
Ignition electronics, starter  
Allumage électronique, dispositif de démarrage  
Bobina encendido, dispositivo de arranque

**DOLMAR**  
A member of the **Trakita** Group

Seite / Page	Pos.	PS-630	PS-6400	PS-7300	PS-7900	PS-6400 D	PS-7300 D	PS-7900 D	PS-6400 H	PS-7300 H	PS-7900 H	PS-6400 DH	PS-7300 DH	PS-7900 DH	PS-6400 (USA)	PS-7300 (USA)	PS-7900 (USA)	PS-6400 H (USA)	PS-7300 H (USA)	PS-7900 H (USA)	Teil-Nr. Part No. No. de pièce No. de pieza	Hinweise Notes Renseign. Nota	Bezeichnung	Spezifikation Specification	Description	Désignation	Denominación
4	101	1	1	1	1	1	1	1	1	1	1	1	1	1	1	1	1	1	1	1	038 160 004		ANWERFVORRICHTUNG ROT KPL.		STARTER ASSY. RED	DISPOS. DE DÉMARRAGE CPL.	DISPOS. DE ARRANQUE CPL. ROJO
4	102	1	1	1	1	1	1	1	1	1	1	1	1	1	1	1	1	1	1	1	928 405 000		SPANNSCHEIBE		DISC	DISQUE	ARANDELA
4	103	1	1	1	1	1	1	1	1	1	1	1	1	1	1	1	1	1	1	1	038 112 031		VENTILATORGEHÄUSE ROT		FAN HOUSING RED	CARTER DE VENTILATEUR	CÁRTER DE VENTILADOR ROJO
4	104	1	1	1	1	1	1	1	1	1	1	1	1	1	1	1	1	1	1	1	001 161 020		ANWERFGRIF		STARTER GRIP	POIGNÉE DE LANCEMENT	TIRADOR DE ARRANQUE
4	105	1	1	1	1	1	1	1	1	1	1	1	1	1	1	1	1	1	1	1	108 164 020		ANWERFSEIL	ø3,5 x 980 mm	STARTER ROPE	CÂBLE DE DÉMARRAGE	CORDÓN DE ARRANQUE
4	106	1	1	1	1	1	1	1	1	1	1	1	1	1	1	1	1	1	1	1	985 000 155	ACC.	ANWERFSEIL	ø 3,5 x 100 m	STARTER ROPE	CÂBLE DE DÉMARRAGE	CORDÓN DE ARRANQUE
4	107	3	3	3	3	3	3	3	3	3	3	3	3	3	3	3	3	3	3	3	908 605 205		INNENSTERN-SCHLITZ-SCHRAUBE	M5x20	SCREW	VIS	TORNILLO
4	108	1	1	1	1	1	1	1	1	1	1	1	1	1	1	1	1	1	1	1	038 162 024		SEILTROMMEL KPL. MIT RÜCKHOLFEDER		CABLE DRUM CPL.	TAMBOUR DE CÂBLE CPL.	TAMBOUR PARA CORDÓN CPL.
4	109	1	1	1	1	1	1	1	1	1	1	1	1	1	1	1	1	1	1	1	924 605 510		SCHEIBE	Ø 5,5x18x1,6	WASHER	RONDELLE	ARANDELA
4	110	1	1	1	1	1	1	1	1	1	1	1	1	1	1	1	1	1	1	1	913 455 204		SCHRAUBE	5,5x20	SCREW	VIS	TORNILLO
4	111	1																			980 115 420		SCHILD	PS-630	LABEL	PLAQUE	CALCOMANIA
4	111		1																		980 115 338		SCHILD	PS-6400	LABEL	PLAQUE	CALCOMANIA
4	111			1																	980 115 339		SCHILD	PS-7300	LABEL	PLAQUE	CALCOMANIA
4	111				1																980 115 340		SCHILD	PS-7900	LABEL	PLAQUE	CALCOMANIA
4	112	1	1	1	1	1	1	1	1	1	1	1	1	1	1	1	1	1	1	1	038 112 020		LUFTFÜHRUNG		AIR DUCT	PLAQUE DE VENTILATION	PLACA VENTILACIÓN
4	113	m	m	m	m	m	m	m	m	m	m	m	m	m	m	m	m	m	m	m	970 502 110		ISOLIERSCHLAUCH	140 mm	INSULATING HOSE	GAINÉ ISOLANTE	MANGO AISLANTE
4	114	1	1	1	1	1	1	1							1	1	1				038 143 041		ZÜNDSPULE KPL. WEINROT		IGNITION COIL RED	BOBINE D' ALLUMAGE ROUGE	BOBINA ENCENDIDO ROJO
4	115	1	1	1	1	1	1	1	1	1	1	1	1	1	1	1	1	1	1	1	038 143 030		KABELBAUM		CABLE HARNESS	FAISCEAU DE CÂBLES	MAZO DE CABLES
4	116	1	1	1	1	1	1	1	1	1	1	1	1	1	1	1	1	1	1	1	957 604 240		ZÜNDKERZENSTECKER KPL.		SPARK PLUG CAP CPL.	FICHE DE BOUGIE, CPL.	TAPA DE BUJIA CPL.
4	117	1	1	1	1	1	1	1	1	1	1	1	1	1	1	1	1	1	1	1	965 603 021		ZÜNDKERZE		SPARK PLUG	BOUGIE	BUJÍA
4	118	1	1	1	1	1	1	1	1	1	1	1	1	1	1	1	1	1	1	1	965 401 011		GUMMITÜLLE		RUBBER BUSHING	GAINÉ CAOUTCHOUC	BOQUILLA DE CAUCHO
4	119	1	1	1	1	1	1	1	1	1	1	1	1	1	1	1	1	1	1	1	957 311 590		MASSELEITUNG	SET	EARTH CABLE	FIL DE MASSE	CONDUCCIÓN A MASA
4	121	2	2	2	2	2	2	2	2	2	2	2	2	2	2	2	2	2	2	2	908 304 205		SCHRAUBE	M4x20	SCREW	VIS	TORNILLO
4	122	1	1	1	1	1	1	1	1	1	1	1	1	1	1	1	1	1	1	1	038 111 110		KLAMMER		CLIP	AGRAFE	GRAPA
4	123	1	1	1	1	1	1	1							1	1	1				957 141 000		POLRAD KPL.		FLYWHEEL CPL.	ROUE POLAIRE CPL.	VOLANTE ENCEND. CPL.
4	124	2	2	2	2	2	2	2	2	2	2	2	2	2	2	2	2	2	2	2	108 166 051		ANWERFKLINKE KPL.		STARTER RATCHET CPL.	CLIQUET CPL.	TRINQUETE ARRANQUE CPL.
4	125	1	1	1	1	1	1	1	1	1	1	1	1	1	1	1	1	1	1	1	926 208 001		FEDERSCHEIBE	B8 DIN137	SPRING WASHER	RONDELLE ÉLASTIQUE	DISCO AMORTIGUADOR
4	126	1	1	1	1	1	1	1	1	1	1	1	1	1	1	1	1	1	1	1	920 208 024		6KT-MUTTER	M8x1	HEXAGONAL NUT	ECROU HEXAGONAL	TUERCA HEXAGONAL
4	181	1	1	1	1	1	1	1	1	1	1	1	1	1	1	1	1	1	1	1	038 162 050		AUSGLEICHSCHEIBE		SPACER	RONDELLE	ARANDELA

PS-630, PS-6400, PS-7300, PS-7900, PS-6400 D, PS-7300 D, PS-7900 D, PS-6400 H, PS-7300 H, PS-7900 H, PS-6400 DH, PS-7300 DH, PS-7900 DH, PS-6400 , PS-7300 , PS-7900 , PS-6400 H , PS-7300 H , PS-7900 H

4

Zündelektronik, Anwerfvorrichtung  
Ignition electronics, starter  
Allumage électronique, dispositif de démarrage  
Bobina encendido, dispositivo de arranque

**DOLMAR**



A member of the **Takita** Group

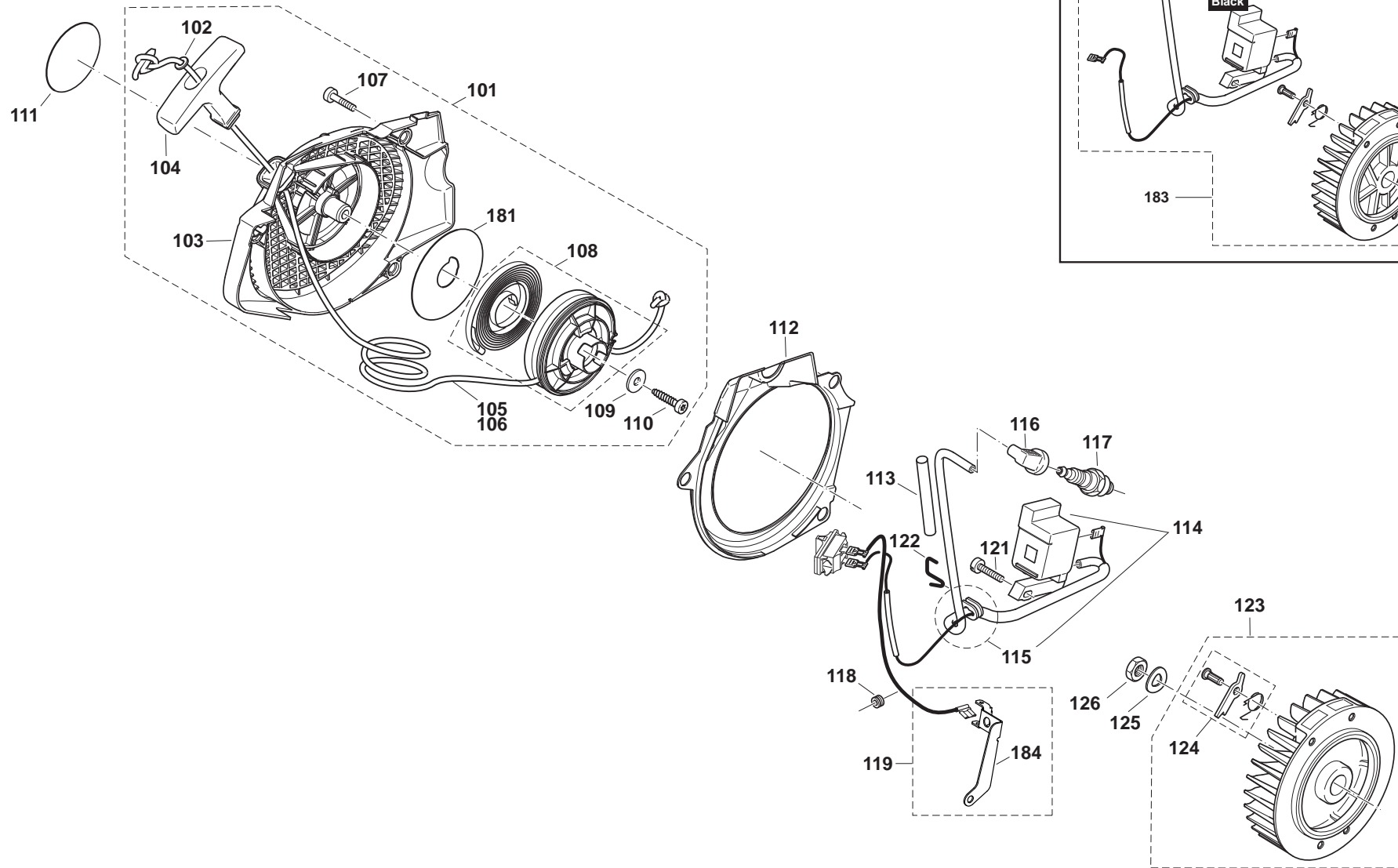



PS-630, PS-6400, PS-7300, PS-7900, PS-6400 D, PS-7300 D, PS-7900 D, PS-6400 H, PS-7300 H, PS-7900 H, PS-6400 DH, PS-7300 DH, PS-7900 DH, PS-6400 , PS-7300 , PS-7900 , PS-6400 H , PS-7300 H , PS-7900 H

4

Zündelektronik, Anwerfvorrichtung  
 Ignition electronics, starter  
 Allumage électronique, dispositif de démarrage  
 Bobina encendido, dispositivo de arranque

**DOLMAR**



A member of the **Takita** Group

Seite / Page	Pos.	PS-630	PS-6400	PS-7300	PS-7900	PS-6400 D	PS-7300 D	PS-7900 D	PS-6400 H	PS-7300 H	PS-7900 H	PS-6400 DH	PS-7300 DH	PS-7900 DH	PS-6400 (USA)	PS-7300 (USA)	PS-7900 (USA)	PS-6400 H (USA)	PS-7300 H (USA)	PS-7900 H (USA)	Teil-Nr. Part No. No. de pièce No. de pieza	Hinweise Notes Renseign. Nota	Bezeichnung	Spezifikation Specification	Description	Désignation	Denominación
4	183	1	1	1	1	1	1	1							1	1	1				010 038 141		POLRAD UND ZÜNDER KPL.		FLYWHEEL AND IGNITION COIL CPL.	ROUE POLAIRE ET BOBINE D' ALLUMAGE CPL.	VOLANTE ENCENDIDO Y BOBINA ENCENDIDO CPL.
4	184	1	1	1	1	1	1	1	1	1	1	1	1	1	1	1	1	1	1	1	038 111 150		KLAMMER MIT MASSEARM		CLAMP	CRAMPON	GRAPA

PS-630, PS-6400, PS-7300, PS-7900, PS-6400 D, PS-7300 D, PS-7900 D, PS-6400 H, PS-7300 H, PS-7900 H, PS-6400 DH, PS-7300 DH, PS-7900 DH, PS-6400 , PS-7300 , PS-7900 , PS-6400 H , PS-7300 H , PS-7900 H

5

Ölpumpe, Kupplung  
 Oil pump, clutch  
 Pompe à huile, embrayage  
 Bomba de aceite, embrague

**DOLMAR**  
 A member of the **Takita** Group

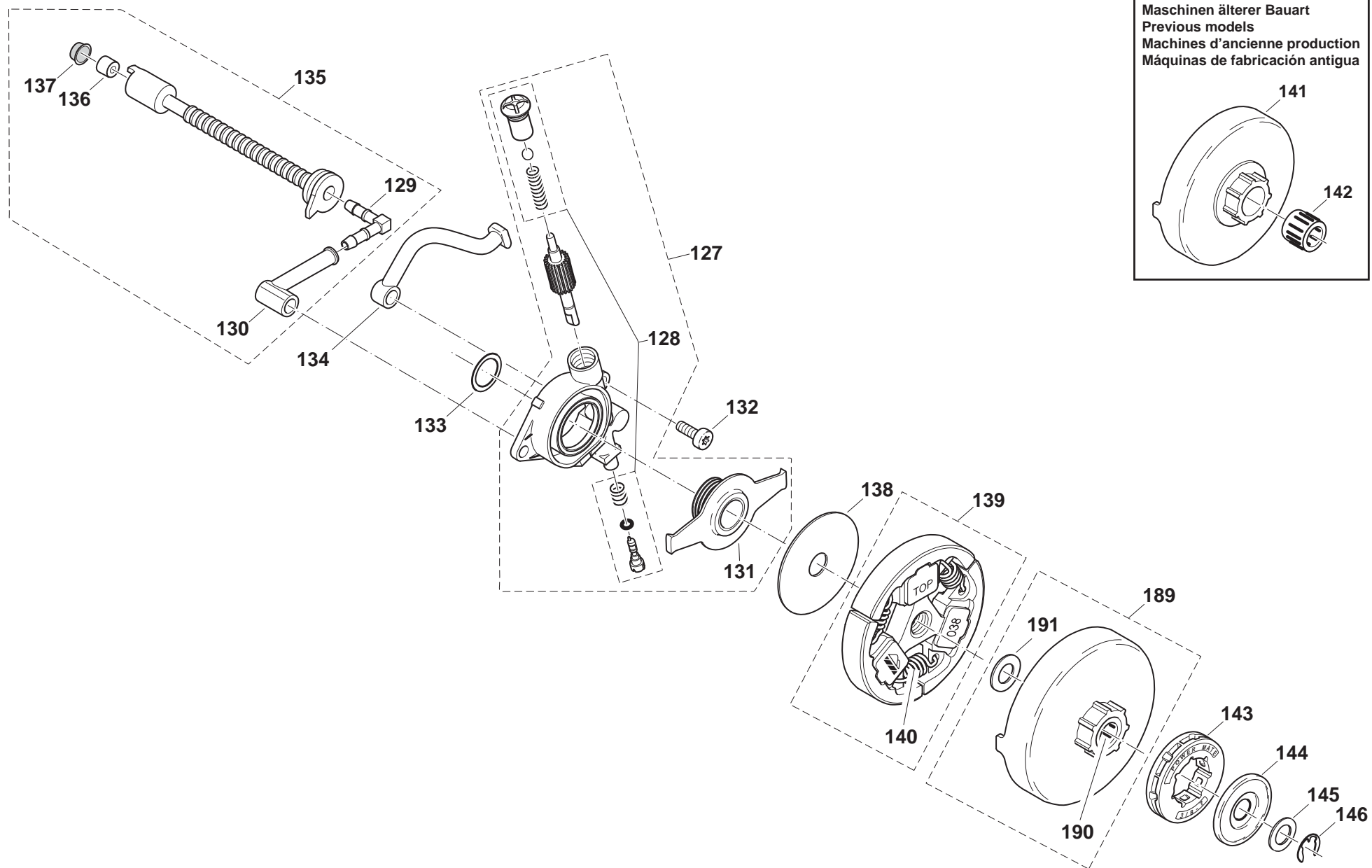

PS-630, PS-6400, PS-7300, PS-7900, PS-6400 D, PS-7300 D, PS-7900 D, PS-6400 H, PS-7300 H, PS-7900 H, PS-6400 DH, PS-7300 DH, PS-7900 DH, PS-6400 , PS-7300 , PS-7900 , PS-6400 H , PS-7300 H , PS-7900 H

5

Ölpumpe, Kupplung  
Oil pump, clutch  
Pompe à huile, embrayage  
Bomba de aceite, embrague

**DOLMAR**  
A member of the **Takita** Group

Seite / Page	Pos.	PS-630	PS-6400	PS-7300	PS-7900	PS-6400 D	PS-7300 D	PS-7900 D	PS-6400 H	PS-7300 H	PS-7900 H	PS-6400 DH	PS-7300 DH	PS-7900 DH	PS-6400 (USA)	PS-7300 (USA)	PS-7900 (USA)	PS-6400 H (USA)	PS-7300 H (USA)	PS-7900 H (USA)	Teil-Nr. Part No. No. de pièce No. de pieza	Hinweise Notes Renseign. Nota	Bezeichnung	Spezifikation Specification	Description	Désignation	Denominación
5	127	1	1	1	1	1	1	1	1	1	1	1	1	1	1	1	1	1	1	1	038 245 010		ÖLPUMPE KPL.		OIL PUMP CPL.	POMPE À HUILE CPL.	BOMBA DE ACEITE CPL.
5	128	1	1	1	1	1	1	1	1	1	1	1	1	1	1	1	1	1	1	1	030 245 070		REPARATURSATZ KPL.		REPAIR KIT CPL.	JEU DE RÉPARATION CPL.	JUEGO DE REPARAR CPL.
5	129	1	1	1	1	1	1	1	1	1	1	1	1	1	1	1	1	1	1	1	001 245 140		WINKELNIPPEL		ANGULAR NIPPLE	TÉTON COUDÉ	BOUQUILLA DE TUBO
5	130	1	1	1	1	1	1	1	1	1	1	1	1	1	1	1	1	1	1	1	038 245 110		ÖLLEITUNG		OIL LINE	CONDUITE HUILE	TUBO ACEITE
5	131	1	1	1	1	1	1	1	1	1	1	1	1	1	1	1	1	1	1	1	038 245 031		PUMPENANTRIEB		PUMP DRIVE	LE COMMANDE DE POMPE	PROPULSOR DE LA BOMBA
5	132	2	2	2	2	2	2	2	2	2	2	2	2	2	2	2	2	2	2	2	908 005 125		INNENSTERN-SCHR AUBE	M5x12	SCREW	VIS	TORNILLO
5	133	1	1	1	1	1	1	1	1	1	1	1	1	1	1	1	1	1	1	1	038 224 021		ANLAUFSCHEIBE		DISC	DISQUE	ARANDELA
5	134	1	1	1	1	1	1	1	1	1	1	1	1	1	1	1	1	1	1	1	038 245 061		ÖLDRUCKLEITUNG		OIL LINE	CONDUITE HUILE	TUBO ACEITE
5	135	1	1	1	1	1	1	1	1	1	1	1	1	1	1	1	1	1	1	1	038 245 020		ÖLSAUGLEITUNG KPL.		SUCTION LINE OIL CPL.	CONDUITE D' ASPIR. HUILE CPL.	CONDUCTO DE ASPIR. ACEITE CPL.
5	136	1	1	1	1	1	1	1	1	1	1	1	1	1	1	1	1	1	1	1	900 005 066		DISTANZRING		DISTANCE RING	BAGUE DE DISTANCE	ANILLO SEPARADOR
5	137	1	1	1	1	1	1	1	1	1	1	1	1	1	1	1	1	1	1	1	963 601 100		SIEB		SCREEN	FILTRE	TAMIZ
5	138	1	1	1	1	1	1	1	1	1	1	1	1	1	1	1	1	1	1	1	001 182 042		FÜHRUNGSSCHEIBE		DISC	DISQUE	DISCO
5	139	1	1	1	1	1	1	1	1	1	1	1	1	1	1	1	1	1	1	1	038 180 011		KUPPLUNG KPL.		CLUTCH ASSY.	EMBRAYAGE CPL.	EMBRAGUE CPL.
5	140	3	3	3	3	3	3	3	3	3	3	3	3	3	3	3	3	3	3	3	024 184 021		ZUGFEDER		SPRING	RESSORT	RESORTE
5	141	1	1	1	1	1	1	1	1	1	1	1	1	1	1	1	1	1	1	1	038 223 020		KUPPLUNGSTROMMEL		CLUTCH DRUM	TAMBOUR	TAMBOR
5	142	1	1	1	1	1	1	1	1	1	1	1	1	1	1	1	1	1	1	1	962 210 024		NADELKÄFIG	10/16X12	NEEDLE CAGE	CAGE À AIGUILLES	JAULA DE AGUJAS
5	143	1	1	1	1	1	1	1	1	1	1	1	1	1	1	1	1	1	1	1	119 224 070		ZAHNKRANZ	3/8" Z=7	RIM SPROCKET	PIGNON	PIÑÓN
5	144	1	1	1	1	1	1	1	1	1	1	1	1	1	1	1	1	1	1	1	181 224 081		TOPFSCHEIBE		DISC	DISQUE	ARANDELA
5	145	1	1	1	1	1	1	1	1	1	1	1	1	1	1	1	1	1	1	1	021 224 011		ANLAUFSCHEIBE	10/16x0,5	SHIM	DISQUE DE DISTANCE	DISCO DE TOPE
5	146	1	1	1	1	1	1	1	1	1	1	1	1	1	1	1	1	1	1	1	927 408 000		SICHERUNGSSCHEIBE	D=8X1,3	WASHER	RONDELLE	ARANDELA
5	189	1	1	1	1	1	1	1	1	1	1	1	1	1	1	1	1	1	1	1	957 223 092		KUPPLUNGSTROMMEL		CLUTCH DRUM	TAMBOUR	TAMBOR
5	190	1	1	1	1	1	1	1	1	1	1	1	1	1	1	1	1	1	1	1	962 300 009		NADELHÜLSE	10/14X12	NEEDLE SLEEVER	DOUILLE D'AIGUILLE	CASQUILLO DE AGUJA
5	191	1	1	1	1	1	1	1	1	1	1	1	1	1	1	1	1	1	1	1	038 223 100		DISTANZSCHEIBE	10,2/18x1,7	SPACER WASHER	RONDELLE D'ÉCARTEMENT	DISCO DISTANCIADOR

PS-630, PS-6400, PS-7300, PS-7900, PS-6400  
D, PS-7300 D, PS-7900 D, PS-6400 H, PS-7300  
H, PS-7900 H, PS-6400 DH, PS-7300 DH,  
PS-7900 DH, PS-6400 , PS-7300 , PS-7900 ,  
PS-6400 H , PS-7300 H , PS-7900 H

6

Kettenbremse  
Chain brake  
Frein de chaîne  
Freno de cadena

**DOLMAR**



A member of the **Takita** Group

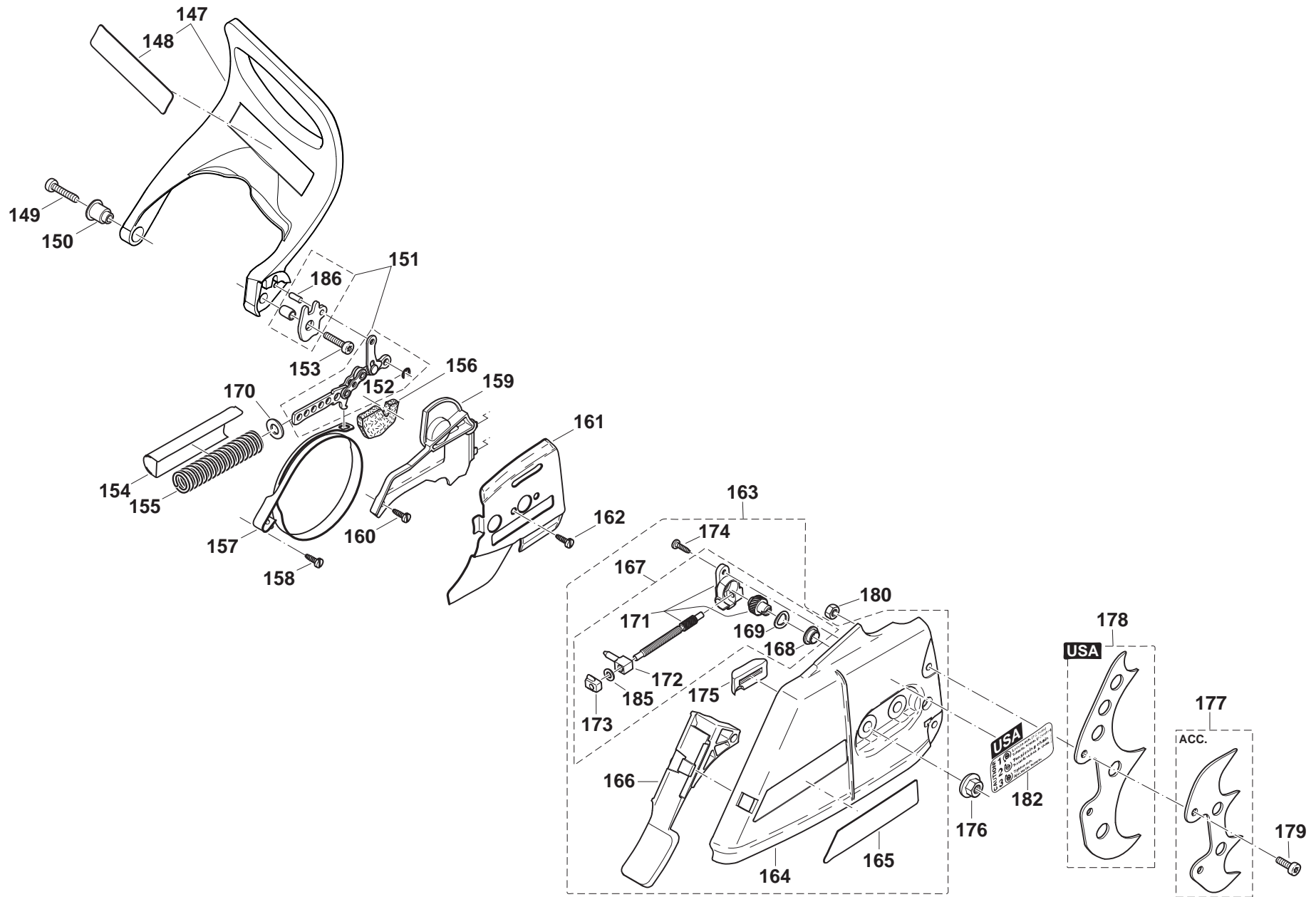

PS-630, PS-6400, PS-7300, PS-7900, PS-6400 D, PS-7300 D, PS-7900 D, PS-6400 H, PS-7300 H, PS-7900 H, PS-6400 DH, PS-7300 DH, PS-7900 DH, PS-6400 , PS-7300 , PS-7900 , PS-6400 H , PS-7300 H , PS-7900 H

6

Kettenbremse  
Chain brake  
Frein de chaîne  
Freno de cadena

**DOLMAR**  
A member of the **Takita** Group

Seite / Page	Pos.	PS-630	PS-6400	PS-7300	PS-7900	PS-6400 D	PS-7300 D	PS-7900 D	PS-6400 H	PS-7300 H	PS-7900 H	PS-6400 DH	PS-7300 DH	PS-7900 DH	PS-6400 (USA)	PS-7300 (USA)	PS-7900 (USA)	PS-6400 H (USA)	PS-7300 H (USA)	PS-7900 H (USA)	Teil-Nr. Part No. No. de pièce No. de pieza	Hinweise Notes Renseign. Nota	Bezeichnung	Spezifikation Specification	Description	Désignation	Denominación
6	147	1	1	1	1	1	1	1	1	1	1	1	1	1	1	1	1	1	1	1	038 213 220		HANDSCHUTZ KPL.		HAND GUARD CPL.	PROTÈGE-MAIN CPL.	PROTECTOR DE MANO CPL.
6	147														1		1				038 213 221	USA	HANDSCHUTZ KPL.	KAT	HAND GUARD CPL.	PROTÈGE-MAIN CPL.	PROTECTOR DE MANO CPL.
6	148	1	1	1	1	1	1	1	1	1	1	1	1	1	1	1	1	1	1	1	980 114 237		SCHILD HANDSCHUTZ		LABEL	PLAQUE	CALCOMANIA
6	149	1	1	1	1	1	1	1	1	1	1	1	1	1	1	1	1	1	1	1	908 405 205		INNENSTERN-SCHRAUBE	M5x20	SCREW	VIS	TORNILLO
6	150	1	1	1	1	1	1	1	1	1	1	1	1	1	1	1	1	1	1	1	038 213 160		BUCHSE		BUSHING	DOUILLE	CASQUILLO
6	151	1	1	1	1	1	1	1	1	1	1	1	1	1	1	1	1	1	1	1	957 213 030		AUSRÜCKMECHANISMUS KPL.		BRAKING MECHANISM	MÉCANISME DE FREINAGE	MECANISMO DE FRENO
6	152	1	1	1	1	1	1	1	1	1	1	1	1	1	1	1	1	1	1	1	927 304 000		SICHERUNGSSCHEIBE		SAFETY WASHER	RONDELLE SÉCURITÉ	ARANDELA SEGURIDAD
6	153	1	1	1	1	1	1	1	1	1	1	1	1	1	1	1	1	1	1	1	908 005 206		ZYLINDERSCHRAUBE	5X20	SCREW	VIS	TORNILLO
6	154	1	1	1	1	1	1	1	1	1	1	1	1	1	1	1	1	1	1	1	038 213 151		FEDERTOPF		POT	CAPUCHON	POTE
6	155	1	1	1	1	1	1	1	1	1	1	1	1	1	1	1	1	1	1	1	038 213 130		DRUCKFEDER		SPRING	RESSORT	RESORTE
6	156	1	1	1	1	1	1	1	1	1	1	1	1	1	1	1	1	1	1	1	038 213 200		SCHAUMSTOFFPLATTE		FOAM SPONGE	PLAQUE DE MOUSSE DE NYLON	CHAPA DE ESPUMA DE PLÁST.
6	157	1	1	1	1	1	1	1	1	1	1	1	1	1	1	1	1	1	1	1	038 213 010		BREMSBAND		BRAKE SPRING	RESSORT DE FREIN	CINTA DE FRENO
6	158	1	1	1	1	1	1	1	1	1	1	1	1	1	1	1	1	1	1	1	915 135 100		SCHNEIDSCHRAUBE	3,5x9,5	SCREW	VIS	TORNILLO
6	159	1	1	1	1	1	1	1	1	1	1	1	1	1	1	1	1	1	1	1	038 213 040		ABDECKPLATTE		PLATE	PLAQUE	PLANCHA
6	160	1	1	1	1	1	1	1	1	1	1	1	1	1	1	1	1	1	1	1	915 135 100		SCHNEIDSCHRAUBE	3,5x9,5	SCREW	VIS	TORNILLO
6	161	1	1	1	1	1	1	1	1	1	1	1	1	1	1	1	1	1	1	1	038 111 030		KETTENFÜHRUNGSBLECH		GUIDE PLATE	TÔLE DE GUIDAGE	CHAPA DE GUÍA
6	162	1	1	1	1	1	1	1	1	1	1	1	1	1	1	1	1	1	1	1	915 135 100		SCHNEIDSCHRAUBE	3,5x9,5	SCREW	VIS	TORNILLO
6	163	1	1	1	1	1	1	1	1	1	1	1	1	1	1	1	1	1	1	1	038 213 103		KETTENRADSCHUTZ KPL. ROT		SPROCKET GUARD CPL. RED	PROTÈGE-PIGNON CPL. ROUGE	PROTECTOR DE PIÑON CPL. ROJO
6	164	1	1	1	1	1	1	1	1	1	1	1	1	1	1	1	1	1	1	1	038 213 035		KETTENRADSCHUTZ ROT		SPROCKET GUARD RED	PROTÈGE-PIGNON ROUGE	PROTECTOR DE PIÑON ROJO
6	165	1	1	1	1	1	1	1	1	1	1	1	1	1	1	1	1	1	1	1	980 114 593		SCHILD	DOLMAR	LABEL	PLAQUE	CALCOMANIA
6	166	1	1	1	1	1	1	1	1	1	1	1	1	1	1	1	1	1	1	1	038 213 190		SPANABWEISER		CHIP GUIDE	GUIDE DE COPEAUX	SALIDA DE VIRUTAS
6	167	1	1	1	1	1	1	1	1	1	1	1	1	1	1	1	1	1	1	1	957 213 023		KETTENSPIANNANTRIEB KPL.		CHAIN TENSIONER CPL.	TENDEUR DE CHAÎNE CPL.	ENSOR DE LA CADENA CPL.
6	168	1	1	1	1	1	1	1	1	1	1	1	1	1	1	1	1	1	1	1	038 213 080		BUCHSE FÜR ANTRIEBSRAD		BUSHING	DOUILLE	CASQUILLO
6	169	1	1	1	1	1	1	1	1	1	1	1	1	1	1	1	1	1	1	1	038 213 230		FEDERSCHEIBE		SPRING WASHER	RONDELLE A RESSORT	ARANDELA ELASTICO
6	170	1	1	1	1	1	1	1	1	1	1	1	1	1	1	1	1	1	1	1	028 213 011		SCHEIBE		WASHER	RONDELLE	ARANDELA
6	171	1	1	1	1	1	1	1	1	1	1	1	1	1	1	1	1	1	1	1	957 213 040		SPANNSCHRAUBE SATZ		TENSIONING SCREW SET	VIS DE TENSION JEU	TORNILLO DE TENSION JUEGO
6	172	1	1	1	1	1	1	1	1	1	1	1	1	1	1	1	1	1	1	1	038 213 091		SPANNMUTTER		TENSIONING NUT	ECROU DE TENSION	TUERCA DE TENSION
6	173	1	1	1	1	1	1	1	1	1	1	1	1	1	1	1	1	1	1	1	038 213 070		SPANNSCHRAUBENLAGER		TENSIONING SCREW BEARING	PALIER DE LA VIS DE TENSION	SOPORTE DEL TORNILLO TENSOR

PS-630, PS-6400, PS-7300, PS-7900, PS-6400 D, PS-7300 D, PS-7900 D, PS-6400 H, PS-7300 H, PS-7900 H, PS-6400 DH, PS-7300 DH, PS-7900 DH, PS-6400 , PS-7300 , PS-7900 , PS-6400 H , PS-7300 H , PS-7900 H

6

Kettenbremse  
Chain brake  
Frein de chaîne  
Freno de cadena

**DOLMAR**



A member of the **Takita** Group

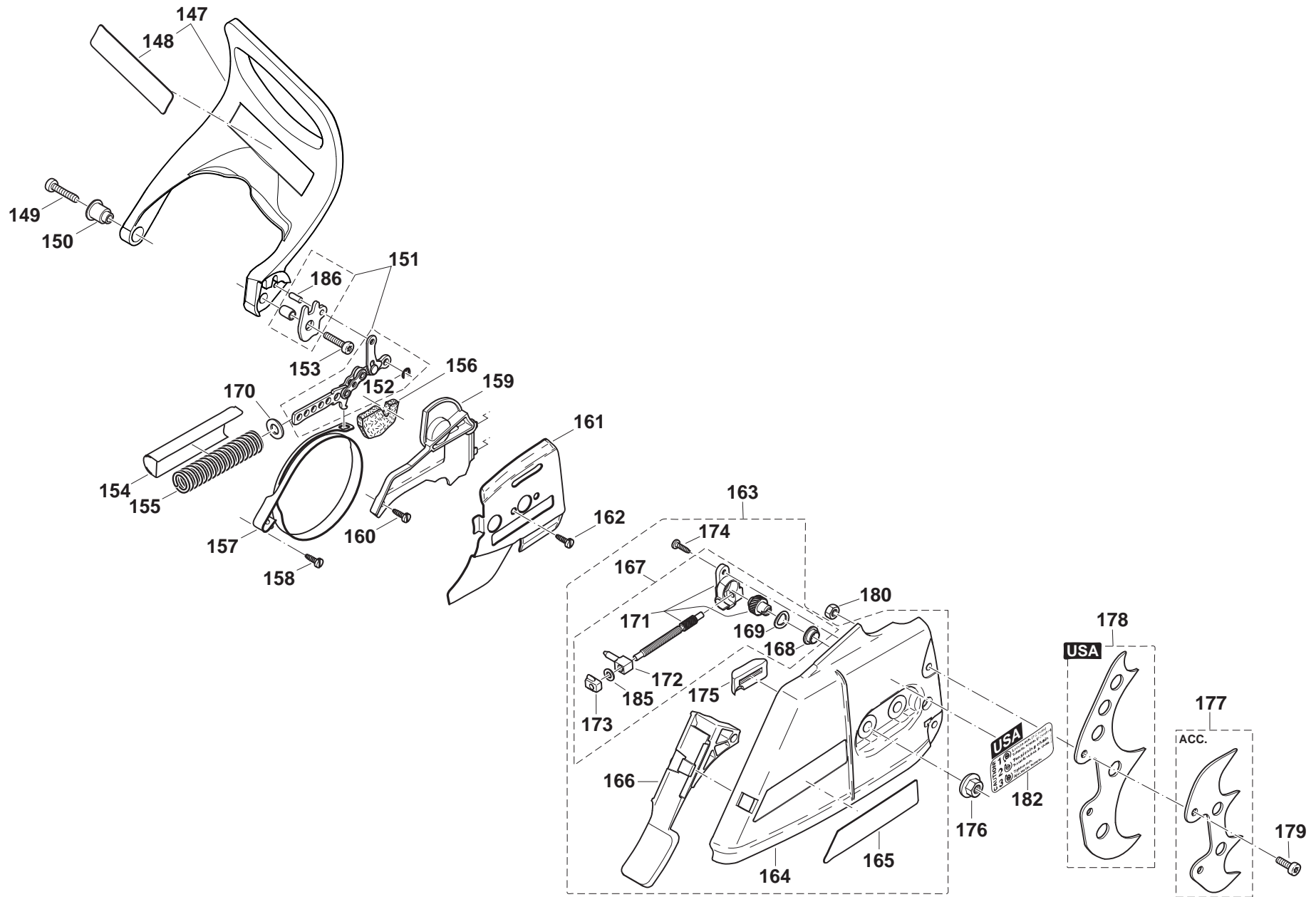

PS-630, PS-6400, PS-7300, PS-7900, PS-6400 D, PS-7300 D, PS-7900 D, PS-6400 H, PS-7300 H, PS-7900 H, PS-6400 DH, PS-7300 DH, PS-7900 DH, PS-6400 , PS-7300 , PS-7900 , PS-6400 H , PS-7300 H , PS-7900 H

6

Kettenbremse  
Chain brake  
Frein de chaîne  
Freno de cadena

**DOLMAR**  
A member of the **Takita** Group

Seite / Page	Pos.	PS-630	PS-6400	PS-7300	PS-7900	PS-6400 D	PS-7300 D	PS-7900 D	PS-6400 H	PS-7300 H	PS-7900 H	PS-6400 DH	PS-7300 DH	PS-7900 DH	PS-6400 (USA)	PS-7300 (USA)	PS-7900 (USA)	PS-6400 H (USA)	PS-7300 H (USA)	PS-7900 H (USA)	Teil-Nr. Part No. No. de pièce No. de pieza	Hinweise Notes Renseign. Nota	Bezeichnung	Spezifikation Specification	Description	Désignation	Denominación
6	174	1	1	1	1	1	1	1	1	1	1	1	1	1	1	1	1	1	1	1	915 135 100		SCHNEIDSCHRAUBE	3,5x9,5	SCREW	VIS	TORNILLO
6	175	1	1	1	1	1	1	1	1	1	1	1	1	1	1	1	1	1	1	1	024 213 240		KETTENFÜHRUNG		CHAIN GUIDE	GUIDE CHAÎNE	GUÍA DE LA CADENA
6	176	2	2	2	2	2	2	2	2	2	2	2	2	2	2	2	2	2	2	2	923 208 004		6KT-MUTTER	M8	HAXAGONAL NUT	ECROU HEXAGONAL	TUERCA HEXAGONAL
6	177	1	1	1	1	1	1	1	1	1	1	1	1	1	1	1	1	1	1	1	957 250 060	ACC.	ZACKENLEISTE KETTENDECKEL KPL.	INCL. POS. 179, 180	SPIKE BAR CPL.	BARRE DENTÉE CPL.	BARRA DENTADA CPL.
6	178		1	1	1	1	1	1	1	1	1	1	1	1	1	1	1	1	1	1	038 250 211	USA	ZACKENLEISTE KETTENDECKEL	USA	SPIKE BAR	BARRE DENTÉE	BARRA DENTADA
6	179	2	2	2	2	2	2	2	2	2	2	2	2	2	2	2	2	2	2	2	908 005 125		INNENSTERN-SCHRAU BE	M5x12	SCREW	VIS	TORNILLO
6	180	2	2	2	2	2	2	2	2	2	2	2	2	2	2	2	2	2	2	2	920 405 000		6KT-MUTTER	M5	HEXAGONAL NUT	ECROU HEXAGONAL	TUERCA HEXAGONAL
6	182	=	=	=	=	=	=	=	=	=	=	=	=	=	=	=	=	=	=	=	980 114 925	USA	SCHILD KETTENSANNER	USA	LABEL	PLAQUE	CALCOMANIA
6	185	1	1	1	1	1	1	1	1	1	1	1	1	1	1	1	1	1	1	1	924 104 300		SCHEIBE	A 4,3	WASHER	RONDELLE	ARANDELA
6	186	1	1	1	1	1	1	1	1	1	1	1	1	1	1	1	1	1	1	1	935 940 100		ZYLINDERSTIFT	4X10	CYLINDRICAL PIN	GOUPILLE CYL.	PRISIONERO

PS-630, PS-6400, PS-7300, PS-7900, PS-6400 D, PS-7300 D, PS-7900 D, PS-6400 H, PS-7300 H, PS-7900 H, PS-6400 DH, PS-7300 DH, PS-7900 DH, PS-6400 , PS-7300 , PS-7900 , PS-6400 H , PS-7300 H , PS-7900 H

7

Vergaser  
Carburetor  
Carburateur  
Carburador

**DOLMAR**



A member of the **Takita** Group

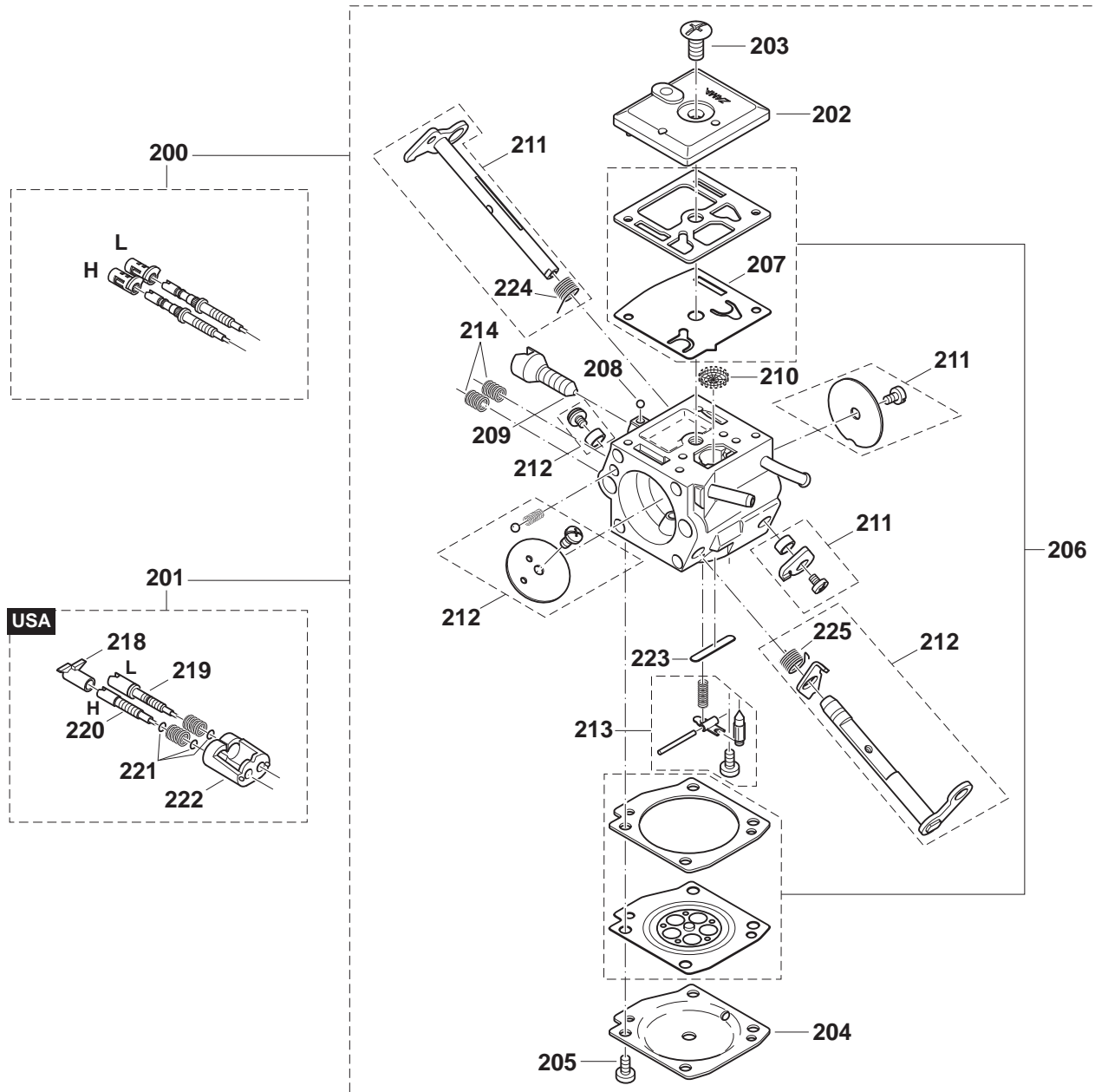



PS-630, PS-6400, PS-7300, PS-7900, PS-6400 D, PS-7300 D, PS-7900 D, PS-6400 H, PS-7300 H, PS-7900 H, PS-6400 DH, PS-7300 DH, PS-7900 DH, PS-6400 , PS-7300 , PS-7900 , PS-6400 H , PS-7300 H , PS-7900 H

7

Vergaser  
Carburetor  
Carburateur  
Carburador

**DOLMAR**  
A member of the **Takita** Group

Seite / Page	Pos.	PS-630	PS-6400	PS-7300	PS-7900	PS-6400 D	PS-7300 D	PS-7900 D	PS-6400 H	PS-7300 H	PS-7900 H	PS-6400 DH	PS-7300 DH	PS-7900 DH	PS-6400 (USA)	PS-7300 (USA)	PS-7900 (USA)	PS-6400 H (USA)	PS-7300 H (USA)	PS-7900 H (USA)	Teil-Nr. Part No. No. de pièce No. de pieza	Hinweise Notes Renseign. Nota	Bezeichnung	Spezifikation Specification	Description	Désignation	Denominación
7	200	1	1	1	1	1	1	1	1	1	1	1	1	1							038 153 014	2004-08 =>	VERGASER	C3M EU	CARBURETOR	CARBURATEUR	CARBURADOR
7	200		1	1	1	1	1	1	1	1	1	1	1								038 153 400	=> 2004-08	VERGASER	C3M	CARBURETOR	CARBURATEUR	CARBURADOR
7	201		1	1	1	1	1	1	1	1	1	1	1	1	1	1	1	1	1	1	038 153 023	USA	VERGASER	C3M USA	CARBURETOR	CARBURATEUR	CARBURADOR
7	202	1	1	1	1	1	1	1	1	1	1	1	1	1	1	1	1	1	1	1	038 153 030		PUMPENDECKEL		PUMP COVER	COUVERCLE DE POMPE	TAPA DE BOMBA
7	203	1	1	1	1	1	1	1	1	1	1	1	1	1	1	1	1	1	1	1	038 153 360		SCHRAUBE		SCREW	VIS	TORNILLO
7	204	1	1	1	1	1	1	1	1	1	1	1	1	1	1	1	1	1	1	1	038 153 040		MEMBRANDECKEL		DIAPHRAGM COVER	COUVERCLE DE MEMBRANE	TAPA DE MEMBRANA
7	205	4	4	4	4	4	4	4	4	4	4	4	4	4	4	4	4	4	4	4	001 153 020		SCHRAUBE FÜR REGELDECKEL		SCREW	VIS	TORNILLO
7	206	1	1	1	1	1	1	1	1	1	1	1	1	1	1	1	1	1	1	1	038 153 410		DICHTUNG UND MEMBRAN, SATZ		SET DIAPHRAGM / GASKETS	JEU DE MEMBRANES / JOINTS	JUEGO MEMBRANAS / JUNTAS
7	207	1	1	1	1	1	1	1	1	1	1	1	1	1	1	1	1	1	1	1	038 153 370	ACC.	PUMPENMEMBRANE, GUMMI		PUMP DIAPHRAGM RUBBER	MEMBRANE DE POMPE CAOUTCH.	MEMBRANA DE LA BOMBA CAUCHO
7	207	1	1	1	1	1	1	1	1	1	1	1	1	1	1	1	1	1	1	1	038 153 070		PUMPENMEMBRANE, TEFLON		PUMP DIAPHRAGM TEFLON	MEMBRANE DE POMPE TEFLON	MEMBRANA DE LA BOMBA TEFLON
7	208	1	1	1	1	1	1	1	1	1	1	1	1	1	1	1	1	1	1	1	038 153 210		ARRETIERSTÜCK		FRICITION BALL	BILLE DE ARRÊT	BOLA
7	209	1	1	1	1	1	1	1	1	1	1	1	1	1	1	1	1	1	1	1	038 153 220		LEERLAUF-ANSCHLAGS CHRAUBE	S	IDLE STOP SCREW	VIS DE BUTÉE DE RALENTI	TORNILLO DE TOPE
7	210	1	1	1	1	1	1	1	1	1	1	1	1	1	1	1	1	1	1	1	036 153 040		SIEB		SCREEN	TAMIS	TAMIZ
7	211	1	1	1	1	1	1	1	1	1	1	1	1	1	1	1	1	1	1	1	957 153 061		REP.-SATZ DROSSELWELLE		KIT THROTTLE SHAFT	JEU AXE CLAPET D'ÉTRANG.	JUEGO EJE VÁLVULA REG.
7	212	1	1	1	1	1	1	1	1	1	1	1	1	1	1	1	1	1	1	1	957 153 051		REP.-SATZ CHOKEWELLE		KIT CHOKE SHAFT	JEU AXE CLAPET D'AIR	JUEGO EJE VÁLVULA AIRE
7	213	1	1	1	1	1	1	1	1	1	1	1	1	1	1	1	1	1	1	1	957 153 100		STEUERTEILE		CONTROL PARTS	PIÈCES DE COMMANDE	PIEZAS DE MANDO
7	214	2	2	2	2	2	2	2	2	2	2	2	2	2	2	2	2	2	2	2	038 153 260		FEDER		SPRING	RESSORT	RESORTE
7	218		1	1	1	1	1	1	1	1	1	1	1	1	1	1	1	1	1	1	038 153 310	USA	LIMITER CAP, ROT	US	LIMITER CAP, RED	CAPUCHON LIMITEUR, ROUGE	CAPUCHONE LIMITADORE, ROJO
7	219		1	1	1	1	1	1	1	1	1	1	1	1	1	1	1	1	1	1	038 153 290	USA	LEERLAUF-STELLSCHR AUBE	L - USA	IDLE ADJUSTMENT SCREW	VIS DE RÉGL. DE RALENTI	TORNILLO REGULADOR
7	220		1	1	1	1	1	1	1	1	1	1	1	1	1	1	1	1	1	1	038 153 300	USA	VOLLGAS-STELLSCHRA UBE	H - USA	MAIN ADJUSTMENT SCREW	VIS DE RÉGL. PLEIN GAZ	TORNILLO REGULADOR
7	221		3	3	3	3	3	3	3	3	3	3	3	3	3	3	3	3	3	3	038 153 250	USA	SCHEIBE	USA	WASHER	RONDELLE	ARANDELA
7	222		1	1	1	1	1	1	1	1	1	1	1	1	1	1	1	1	1	1	038 153 320	USA	EINSTELLFÜHRUNG	US	ADJUSTING GUIDE	GUIDAGE D' AJUSTAGE	GUÍA DE AJUSTE
7	223	1	1	1	1	1	1	1	1	1	1	1	1	1	1	1	1	1	1	1	038 153 350		VERSCHLUßSCHEIBE		PLUG-WELCH	RONDELLE DE FERMETURE	DISCO DE CIERRE
7	224	1	1	1	1	1	1	1	1	1	1	1	1	1	1	1	1	1	1	1	038 153 150		DREHFEDER FÜR DROSSELKLAPPE		SPRING	RESSORT	RESORTE
7	225	1	1	1	1	1	1	1	1	1	1	1	1	1	1	1	1	1	1	1	038 153 100		DREHFEDER		SPRING	RESSORT	RESORTE

PS-630, PS-6400, PS-7300, PS-7900, PS-6400 D, PS-7300 D, PS-7900 D, PS-6400 H, PS-7300 H, PS-7900 H, PS-6400 DH, PS-7300 DH, PS-7900 DH, PS-6400 , PS-7300 , PS-7900 , PS-6400 H , PS-7300 H , PS-7900 H

# 8

Spezialteile für Ausrüstung mit elektrischer Griffheizung  
Special parts for version with electric handle heating  
Pièces spéciales pour version avec chauffage de la poignée (électrique)  
Piezas especiales por tipo con calefacción eléctrica de mango

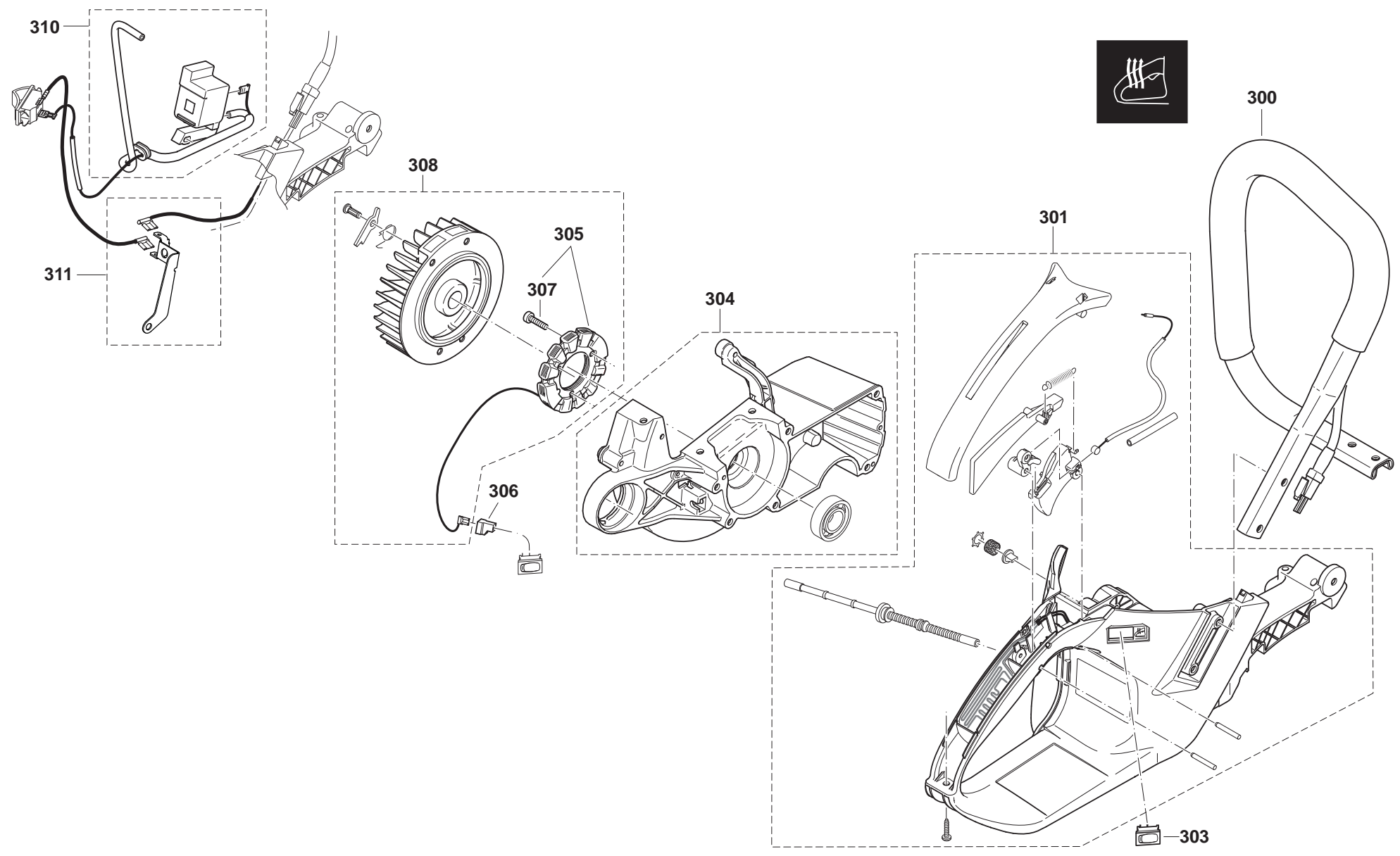

PS-630, PS-6400, PS-7300, PS-7900, PS-6400 D, PS-7300 D, PS-7900 D, PS-6400 H, PS-7300 H, PS-7900 H, PS-6400 DH, PS-7300 DH, PS-7900 DH, PS-6400 , PS-7300 , PS-7900 , PS-6400 H , PS-7300 H , PS-7900 H

8

Spezialteile für Ausrüstung mit elektrischer Griffheizung  
 Special parts for version with electric handle heating  
 Pièces spéciales pour version avec chauffage de la poignée (électrique)  
 Piezas especiales por tipo con calefacción eléctrica de mango



Seite / Page	Pos.	PS-6400 H	PS-7300 H	PS-7900 H	PS-6400 DH	PS-7300 DH	PS-7900 DH	PS-6400 H (USA)	PS-7300 H (USA)	PS-7900 H (USA)	Teil-Nr. Part No. No. de pièce No. de pieza	Hinweise Notes Renseign. Nota	Bezeichnung	Spezifikation Specification	Description	Désignation	Denominación
8	300	1	1	1	1	1	1	1	1	1	038 310 030		BÜGELGRIFF KPL. (HEIZUNG)		TUBULAR HANDLE ASSY.	POIGNÉE TUBULAIRE CPL.	MANGO TUBULAR CPL.
8	301	1	1	1	1	1	1	1	1	1	038 114 073		TANK KPL. ROT (HEIZUNG)		TANK CPL. RED	RÉSERVOIR CPL. ROUGE	DEPÓSITO CPL. ROJO
8	303	1	1	1	1	1	1	1	1	1	975 001 250		SCHALTER		SWITCH	INTERRUPTEUR	INTERRUPTOR
8	304	1	1	1	1	1	1	1	1	1	038 111 180		KURBELGEHÄUSE MS ROT	Heizung, heating	CRANKC. MAG. SIDE RED	CARTER-COTÉ MAGN. ROUGE	CÁRTER CIG. LADO MAG. ROJO
8	305	1	1	1	1	1	1	1	1	1	957 148 020		GENERATORANKER	SET	GENERATOR COIL	BOBINE GÉNÉRATRICE	BOBINA GENERADOR
8	306	1	1	1	1	1	1	1	1	1	038 146 030		ISOLIERKAPPE GELB		INSULATING CAP	CHAPE D'ISOLATION	CUBIERTO DE AISLADOR
8	307	3	3	3	3	3	3	3	3	3	913 340 205		SCHRAUBE	4X20	SCREW	VIS	TORNILLO
8	308	1	1	1	1	1	1	1	1	1	957 148 000		POLRAD KPL. (HEIZUNG UNGEREGELT)		FLYWHEEL ASSY.	ROUE POLAIRE CPL.	VOLANTE ENCENDIDO
8	310	1	1	1	1	1	1	1	1	1	038 143 041		ZÜNDSPULE KPL. WEINROT		IGNITION COIL RED	BOBINE D' ALLUMAGE ROUGE	BOBINA ENCENDIDO ROJO
8	311	1	1	1	1	1	1	1	1	1	957 311 590		MASSELEITUNG	SET	EARTH CABLE	FIL DE MASSE	CONDUCCIÓN A MASA

PS-630, PS-6400, PS-7300, PS-7900, PS-6400 D, PS-7300 D, PS-7900 D, PS-6400 H, PS-7300 H, PS-7900 H, PS-6400 DH, PS-7300 DH, PS-7900 DH, PS-6400 , PS-7300 , PS-7900 , PS-6400 H , PS-7300 H , PS-7900 H

9

Sägeschienen, Sägeketten, Werkzeug  
Guide bars, saw chains, tools  
Guide-chaîne, chaînes, outils  
Rieles guía, cadenas sierra, herramientas

**DOLMAR**



A member of the **Trakita** Group

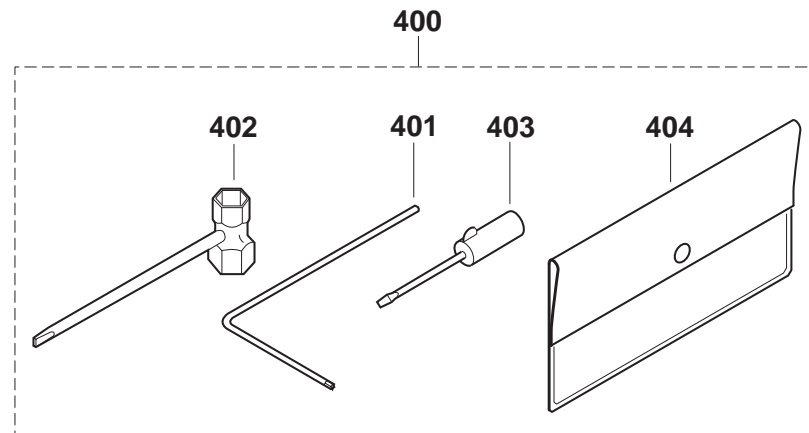
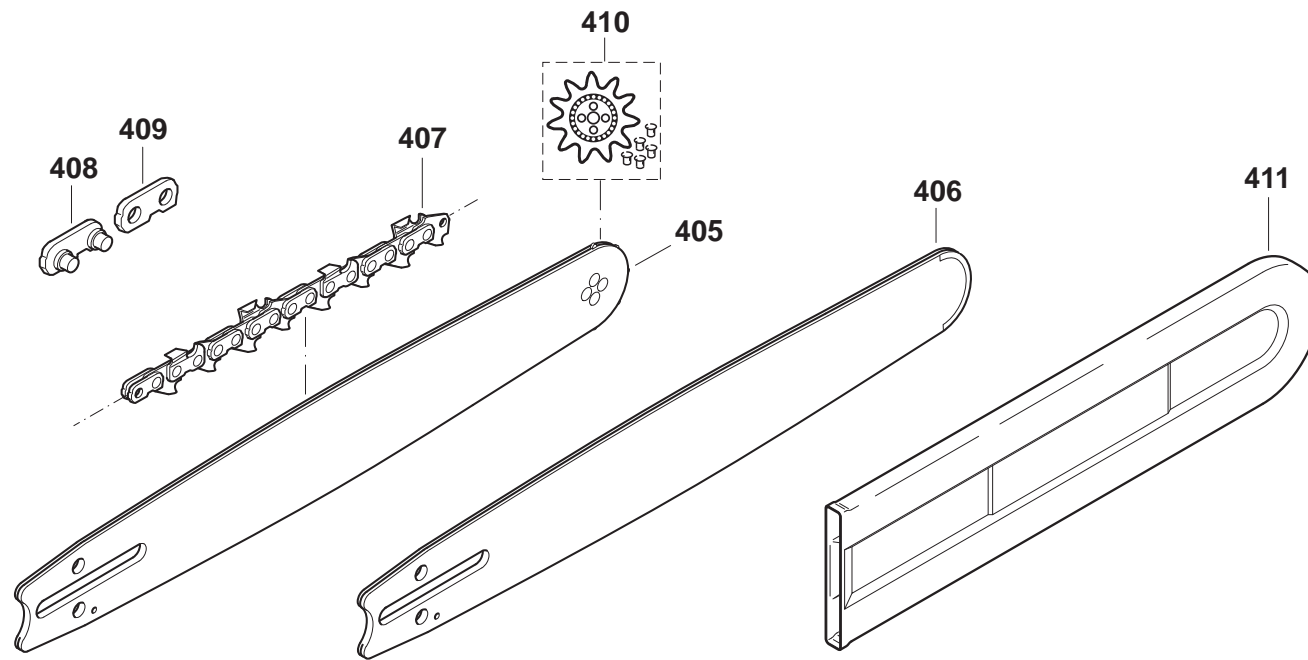

PS-630, PS-6400, PS-7300, PS-7900, PS-6400 D, PS-7300 D, PS-7900 D, PS-6400 H, PS-7300 H, PS-7900 H, PS-6400 DH, PS-7300 DH, PS-7900 DH, PS-6400 , PS-7300 , PS-7900 , PS-6400 H , PS-7300 H , PS-7900 H

9

Sägeschienen, Sägeketten, Werkzeug  
Guide bars, saw chains, tools  
Guide-chaîne, chaînes, outils  
Rieles guía, cadenas sierra, herramientas

**DOLMAR**  
A member of the **Takita** Group

Seite / Page	Pos.	PS-630	PS-6400	PS-7300	PS-7900	PS-6400 D	PS-7300 D	PS-7900 D	PS-6400 H	PS-7300 H	PS-7900 H	PS-6400 DH	PS-7300 DH	PS-7900 DH	PS-6400 (USA)	PS-7300 (USA)	PS-7900 (USA)	PS-6400 H (USA)	PS-7300 H (USA)	PS-7900 H (USA)	Teil-Nr. Part No. No. de pièce No. de pieza	Hinweise Notes Renseign. Nota	Bezeichnung	Spezifikation Specification	Description	Désignation	Denominación	
9	400	1	1	1	1	1	1	1	1	1	1	1	1	1	1	1	1	1	1	1	1	957 004 002		WERKZEUG KPL.		TOOL CPL.	OUTILS CPL.	HERRAMIENTAS CPL.
9	401	1	1	1	1	1	1	1	1	1	1	1	1	1	1	1	1	1	1	1	1	940 827 000		WINKELSCHRAUBEN DREHER	T27	ANGLED SCREW DRIVER	CLÉ ANGLE	LLAVE ANGULAR
9	402	1	1	1	1	1	1	1	1	1	1	1	1	1	1	1	1	1	1	1	1	941 719 131		KOMBISCHLÜSSEL	SW 13/19	UNIVERSAL WRENCH	CLÉ COMBINÉE	LLAVE DE BUJIA
9	403	1	1	1	1	1	1	1	1	1	1	1	1	1	1	1	1	1	1	1	1	944 340 001		SCHRAUBENDREHER		SCREW DRIVER	TOURNEVIS	DESTORNILLADOR
9	404	1	1	1	1	1	1	1	1	1	1	1	1	1	1	1	1	1	1	1	1	950 004 001		WERKZEUGTASCHE		PLASTIK BAG	POCHETTE EN PLASTIQUE	CARTERA HERRAMIENTAS
9	405	1	1	1	1	1	1	1	1	1	1	1	1	1	1	1	1	1	1	1	1	415 035 655		STERNSCHIENE	3/8" .058" 35CM-14"	SPROCKET NOSE BAR	GUIDE À ÉTOILE	GUÍA CON ESTRELLA
9	405	1	1	1	1	1	1	1	1	1	1	1	1	1	1	1	1	1	1	1	1	415 038 655		STERNSCHIENE	3/8" .058" 38CM-15"	SPROCKET NOSE BAR	GUIDE À ÉTOILE	GUÍA CON ESTRELLA
9	405	1	1	1	1	1	1	1	1	1	1	1	1	1	1	1	1	1	1	1	1	415 045 655		STERNSCHIENE	3/8" .058" 45CM-18"	SPROCKET NOSE BAR	GUIDE À ÉTOILE	GUÍA CON ESTRELLA
9	405	1	1	1	1	1	1	1	1	1	1	1	1	1	1	1	1	1	1	1	1	415 050 655		STERNSCHIENE	3/8" .058" 50CM-20"	SPROCKET NOSE BAR	GUIDE À ÉTOILE	GUÍA CON ESTRELLA
9	405	1	1	1	1	1	1	1	1	1	1	1	1	1	1	1	1	1	1	1	1	415 060 655		STERNSCHIENE	3/8" .058" 60CM-24"	SPROCKET NOSE BAR	GUIDE À ÉTOILE	GUÍA CON ESTRELLA
9	406	1	1	1	1	1	1	1	1	1	1	1	1	1	1	1	1	1	1	1	1	415 045 455		PANZERSCHIENE	3/8" .058" 45CM-18"	SOLID NOSE BAR	GUIDE BLINDÉ	GUÍA BLINDADA
9	406	1	1	1	1	1	1	1	1	1	1	1	1	1	1	1	1	1	1	1	1	415 050 455		PANZERSCHIENE	3/8" .058" 50CM-20"	SOLID NOSE BAR	GUIDE BLINDÉ	GUÍA BLINDADA
9	406	1	1	1	1	1	1	1	1	1	1	1	1	1	1	1	1	1	1	1	1	415 060 455	TI 2001/16	PANZERSCHIENE	3/8" .058" 60CM-24"	SOLID NOSE BAR	GUIDE BLINDÉ	GUÍA BLINDADA
9	406	1	1	1	1	1	1	1	1	1	1	1	1	1	1	1	1	1	1	1	1	415 070 455		PANZERSCHIENE	3/8" .058" 70CM-28"	SOLID NOSE BAR	GUIDE BLINDÉ	GUÍA BLINDADA
9	407	1	1	1	1	1	1	1	1	1	1	1	1	1	1	1	1	1	1	1	1	528 099 056		SÄGEKETTE	3/8" .058" 35/38CM-14/15"	SAW CHAIN	CHAÎNE	CADENA
9	407	1	1	1	1	1	1	1	1	1	1	1	1	1	1	1	1	1	1	1	1	528 099 060		SÄGEKETTE	3/8" .058" 38CM-15"	SAW CHAIN	CHAÎNE	CADENA
9	407	1	1	1	1	1	1	1	1	1	1	1	1	1	1	1	1	1	1	1	1	528 099 068		SÄGEKETTE	3/8" .058" 45CM-18"	SAW CHAIN	CHAÎNE	CADENA
9	407	1	1	1	1	1	1	1	1	1	1	1	1	1	1	1	1	1	1	1	1	528 099 072		SÄGEKETTE	3/8" .058" 50CM-20"	SAW CHAIN	CHAÎNE	CADENA
9	407	1	1	1	1	1	1	1	1	1	1	1	1	1	1	1	1	1	1	1	1	528 099 084	TI 2001/16	SÄGEKETTE	3/8" .058" 60CM-24"	SAW CHAIN	CHAÎNE	CADENA
9	407	1	1	1	1	1	1	1	1	1	1	1	1	1	1	1	1	1	1	1	1	528 099 094		SÄGEKETTE	3/8" .058" 70CM-28"	SAW CHAIN	CHAÎNE	CADENA
9	408	1	1	1	1	1	1	1	1	1	1	1	1	1	1	1	1	1	1	1	1	558 093 010		AUßENLASCHE MIT NIET	3/8" .058"	TIE STRAP WITH RIVETS	ECLISSE AVEC RIVETS	TIRA EXT. CON REMACHERS
9	409	1	1	1	1	1	1	1	1	1	1	1	1	1	1	1	1	1	1	1	1	558 093 000		AUßENLASCHE	3/8" .058"	TIE STRAP	ECLISSE EXTERIEURE	TIRA EXT.
9	410	1	1	1	1	1	1	1	1	1	1	1	1	1	1	1	1	1	1	1	1	415 038 720		UMLENKSTERN	3/8" .058"	SPROCKET NOSE	ÉTOILE	ESTRELLA
9	411	1	1	1	1	1	1	1	1	1	1	1	1	1	1	1	1	1	1	1	1	952 020 150		KETTENSCHUTZ	50 cm	CHAIN PROTECTION	PROTECTION CHAÎNE	PROTECTOR DE CADENA
9	411	1	1	1	1	1	1	1	1	1	1	1	1	1	1	1	1	1	1	1	1	952 020 160		KETTENSCHUTZ	60 cm	CHAIN PROTECTION	PROTECTION CHAÎNE	PROTECTOR DE CADENA
9	411	1	1	1	1	1	1	1	1	1	1	1	1	1	1	1	1	1	1	1	1	952 030 180		KETTENSCHUTZ	80 cm	CHAIN PROTECTION	PROTECTION CHAÎNE	PROTECTOR DE CADENA

PS-630, PS-6400, PS-7300, PS-7900, PS-6400  
D, PS-7300 D, PS-7900 D, PS-6400 H, PS-7300  
H, PS-7900 H, PS-6400 DH, PS-7300 DH,  
PS-7900 DH, PS-6400 , PS-7300 , PS-7900 ,  
PS-6400 H , PS-7300 H , PS-7900 H

**DOLMAR**



A member of the **Takita** Group

	<b>Zeichenerklärung</b>	<b>Key to symbols</b>	<b>Légende</b>	<b>Explicación de símbolos</b>
=> 1999999 2000000 => 2003.04 => TI 2003/07 <b>Acc.</b> = { <b>m</b> <b>Corr.</b>	Produktion bis Serien-Nr. Neues Teil ab Serien-Nr. Neues Teil ab Jahr / Monat Siehe Technische Information Jahr / Nr. Zubehör (nicht im Lieferumfang) Keine Serienausführung, jedoch verwendbar Beinhaltet Positions-Nr. Meterware Druckfehlerberichtigung	Production to serial number New part from serial number New part from Year / Month See Technical Information Year / No. Accessories (not included in the delivery inventory) No standard execution, may be used Contains item number Sold by the meter Error correction	Production jusqu'à n° de série Nouveau pièce à partir du n° de série Nouveau pièce à partir de année / mois Voir information technique année / n° Accessoires (non compris dans la livraison) Aucune exécut. en série, cependant utilisable contient n° de numéro Au mètre Rectification d'erreurs	Producción hasta N° de serie Pieza nueva a partir de N° de serie Pieza nueva a partir de año / mes Véase inform. técnico año / N° Accesorios (no incluido en la extensión del suministro) No es de serie, pero sirve Contiene pos N° Por metro Fe de erratas
	Änderungen vorbehalten	Specifications subject to change without notice	Changements sans préavis	Mejoras constructivas sin previo aviso