

SECTION 12: Illustrated Parts
Model 993

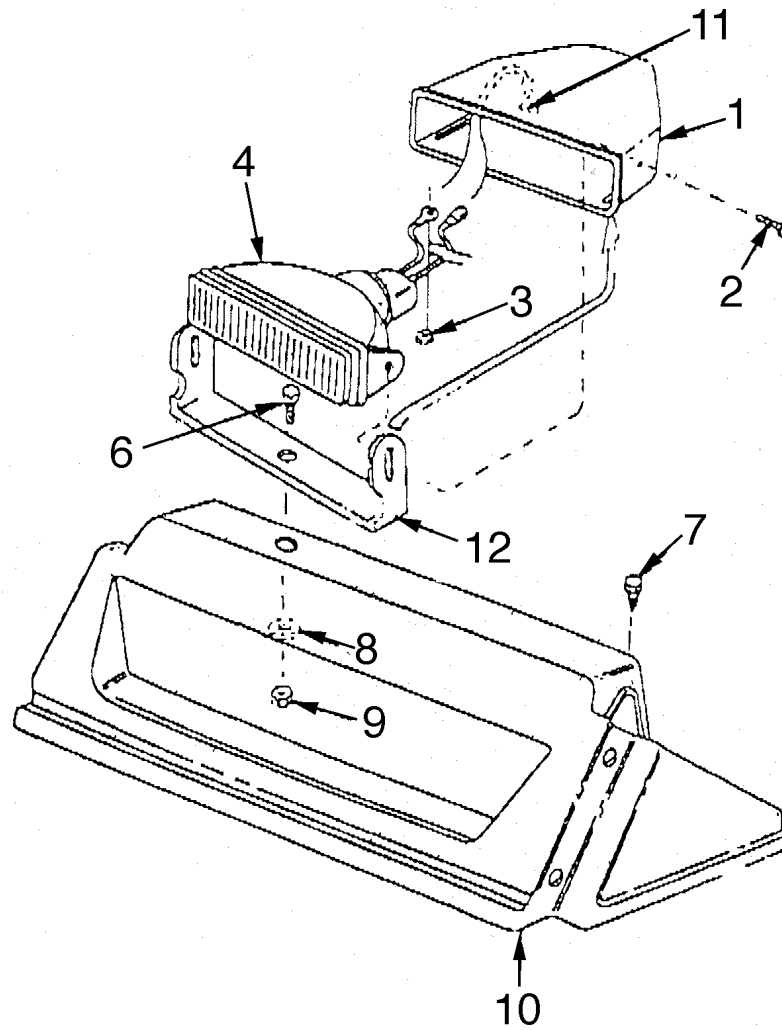

Ref. No.	Part No.	Description	Qty.
1	731-1364	Halogen Lamp Housing	1
2	710-1240	Phillips Pan Head Screw M 4 x 16	2
3	712-0271	Hex Sems Nut 1/4-20	1
4	725-1669	Lamp/Lens Housing Ass'y	1
	629-0059	Halogen Light Wire Harness	1
	725-1658	#890 Halogen Bulb	1
6	710-0451	Carriage Bolt 5/16-18 x .75	1
7	710-1003	Pan Head B-Tapp Screw #10	2
8	736-0159	FI-Wash .344 ID x .88 OD	1
9	712-0429	Hex Ins L-Nut 5/16-18	1
10	731-1873A	Handle Panel	1
	735-0225	Grommet .38 ID x .50 OD x 12	1
12	705-5217	Lamp Mounting Bracket	1

Model 993

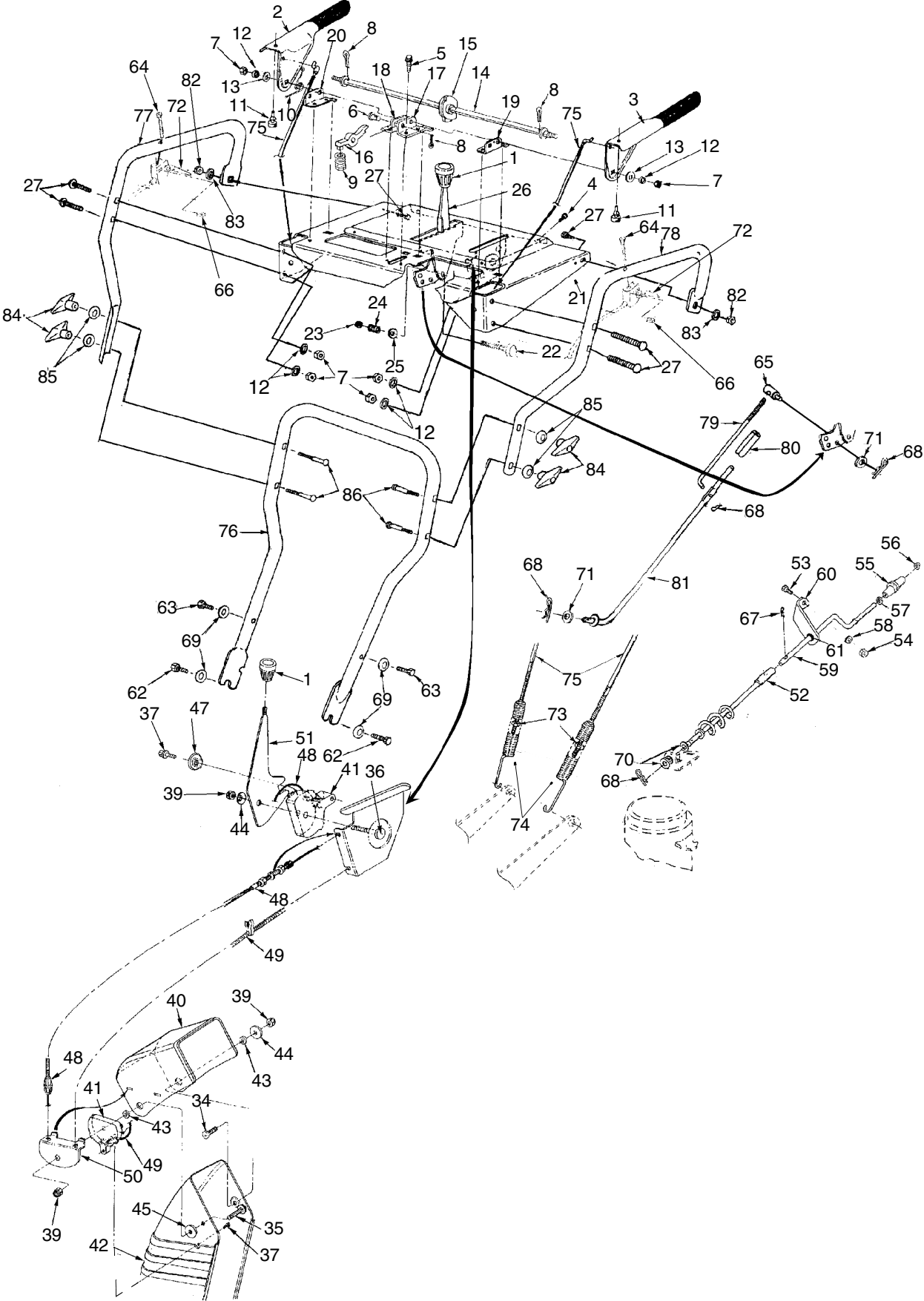

Model 993

Ref. No.	Part No.	Description	Qty.	Ref. No.	Part No.	Description	Qty.
1	720-0232	Sml Shift Knob	2	48	746-0902	Chute Control Cable 66"	1
2	705-5218	Engage Handle RH	1	49	746-0903	Chute Control Cable 66" W/clip	1
3	705-5219	Engage Handl LH	1	50	784-5594	Cable Bracket Chute Tilt	1
4	710-0351	Pan Head B-tapp Scr #10 x .5	2	51	784-5604	Chute Tilt Handle	1
5	710-0599	Hwhd Sf-tap Scr 1/4-20 x 1/2 Lg.	4	52	684-0053A	Lower Chute Directional Control	1
6	711-0653	Clevis Pin .31 Dia x 1.0	1	53	710-3015	Hex Scr 1/4-20 x .75 Lg Gd5	1
7	712-3010	Nut Hex 5/16-18 Gd 5	6	54	712-0287	Hex Nut 1/4-20	1
8	714-0507	Cot-pin 3/32 Dia x 1.0	3	55	720-0201A	Chute Directional Control Knob	1
9	732-0145	Comp Spring .36 Dia x 1.0 Lg	1	56	726-0100	Push Cap 3/8 Palnut #375011	1
10	732-0746	Spring Torsion .44 ID	1	57	736-0117	Flat Washer .38 ID x .60 OD x .033	1
11	735-0199A	Rubber Bumper .63 Dia	2	58	736-0270	Bell Wash .26 ID x .75 OD x .06T	1
12	736-0119	Lock Washer 5/16	6	59	747-0624	Upper Chute Directional Control	1
13	736-0509	Wsher Spcl. .345 Sq. x .72 OD	2	60	705-5266	Brkt Chute Directional Control	1
14	747-0877	Cam Rod	2	61	741-0475	Plastic Bushing .380 ID	4
15	748-0362	Clutch Lock Cam	2	62	710-0216	Hex Scr 3/8-16 x .75	2
16	748-0363	Clutch Lock Pawl	1	63	710-0347	Hex Scr 3/8-16 x 1.75	2
17	784-5679	Supt Brkt 5/8 Lh	1	64	710-1625	Scr Oval C/sunk #10-24 x 1.75	2
18	784-5680	Supt Brkt 5/8 Rh	1	65	711-0677	Adjustment Ferrule	1
19	784-5681	Supt Brkt 3/8 Lh	1	66	712-0127	#10-24 Flat Weld Nut	2
20	784-5682	Supt Brkt 3/8 Rh	1	67	714-0101	Internal Cot-pin 1/2 Dia	1
21	684-0102	Pnl Asm Hndl W/tilt	1	68	714-0104	Inter Cot-pin 5/16 Dia	4
22	710-0459A	Scr Hex Cap 3/8-24 x 1.5 Gd 5	1	69	736-0105	Bell Wash .4 ID x .88 OD x .06	4
23	712-0116	Hex Ins L-nut 3/8-24	1	70	736-0185	Fl-wash .406 ID x .74 OD x .063	2
24	732-0193	Compression Spring .39 ID x .88	1	71	736-0275	Fl-wash Sae .34 x .68 x .062	2
25	736-0105	Bell Wash .40 ID x .88 OD x .06	1	72	746-0950	Trigger Ass'y Steer	2
26	784-5619A	Shift Handle	1	73	712-0324	Hex Ins L-nut 1/4-20	2
27	710-0458	Carriage Bolt 5/16-18 x 1.75	6	74	732-0184	Extension Spring	2
34	710-0276	Carriage Bolt 5/16-18 x 1.00	1	75	746-0952	Cable Clutch Drive	2
35	710-0458	Carriage Bolt 5/16-18 x 1.75	1	76	646-0012	Handle Lower	2
36	710-0805	Hex Scr 5/16-18 x 1.5	1	77	749-0990A	Handle Upper Rh	1
37	710-0896	HWHd B Tapp Scr 1/4 x 5/8 Zn	2	78	749-0989A	Handle Upper Lh	1
39	712-0429	Hex Ins L-nut 5/16-18	3	79	747-0997	Upper Shift Rod 5/16 x 10.57	1
40	731-0846C	6" Upper Chute Remote Tilt	1	80	750-0963	2 Pc Shift Rod Connector	1
41	731-1313C	Chute Tilt Cable Guide	2	81	747-0983	Lower Shift Rod 3/8 x 14.75	1
42	731-0903D	6" Lower Chute Remote Tilt	1	82	712-0287	Hex Nut 1/4 - 20	2
43	731-1319	Chute Pivot Spacer	2	83	736-0270	Bell Wash .26 ID x .75 OD x .06T	2
44	736-0159	Fl-wash .344 ID x .88 OD x .063	2	84	720-0284	Wingnut	4
45	736-0231	Flt Wshr .344 x 1.125 x .125	1	85	736-0242	Bell Wash .345 ID x .88 OD x .060	4
47	736-0506	Contoured Washer	1	86	710-0572	Carriage Bolt 5/16 -18 x 2.5	4

NOTE: For painted parts, please refer to the list of color codes below. Please add the applicable color code, wherever needed, to the part number to order a replacement part. For instance, if a part, numbered 700-xxxx, is painted yard-man green, the part number to order would be 700-xxxx-0665.

Yard-Man Green: 0665
Yard-Man Yellow: 0674
Powder Black: 0637

Model 993

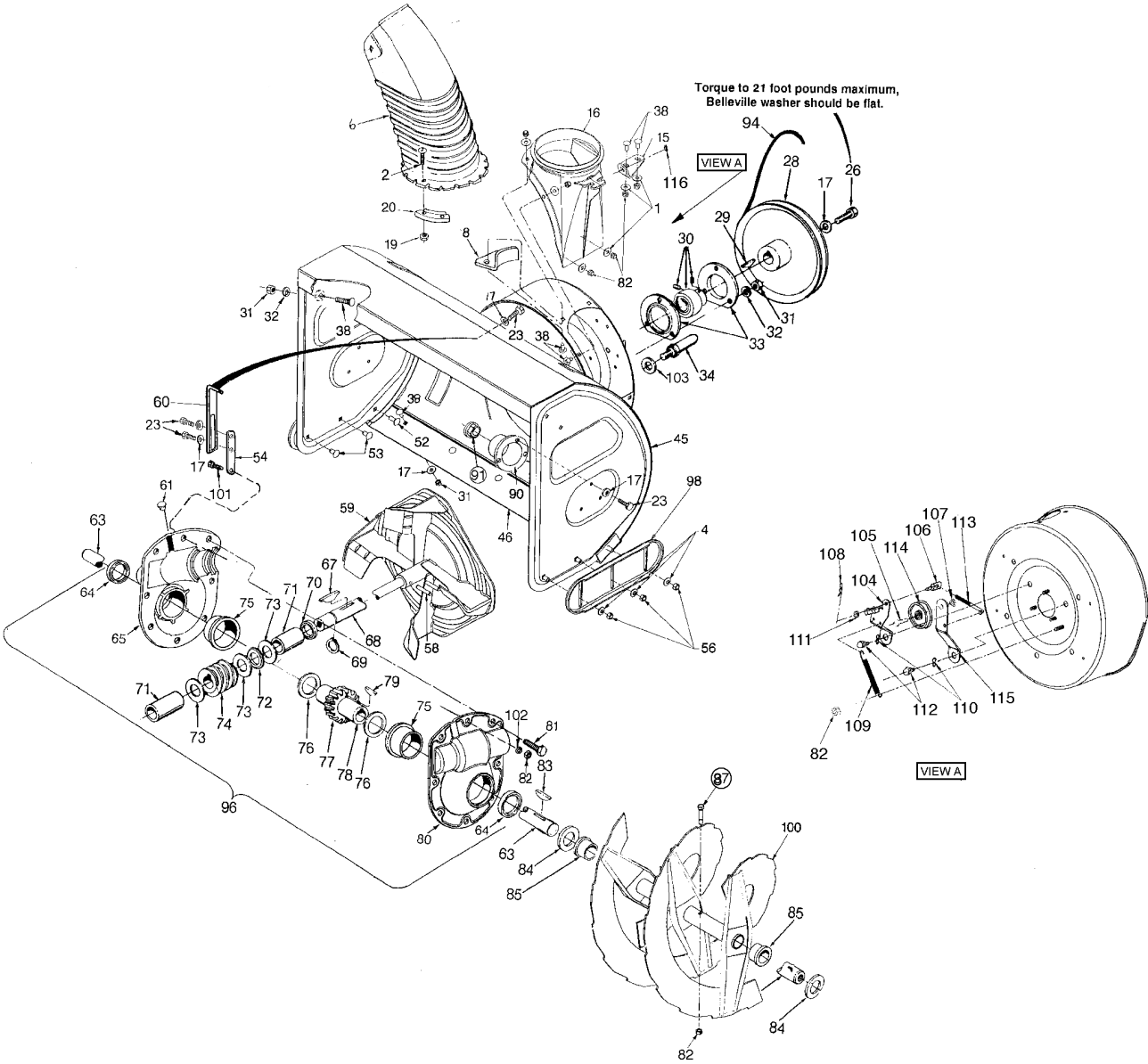

Model 993

Ref. No.	Part No.	Description	Qty.	Ref. No.	Part No.	Description	Qty.
1	736-0159	Flat Washer .344 ID x .875 OD	7	72	741-0184	Thrust Bearing .88 ID x 1.44 OD x .078	1
2	710-3015	Truss. Hd. Mach. Scr. 1/4-20 x .75	6				
4	736-0105	Belleville washer	6	73	736-0291	Flat Washer .88 ID x 1.4 OD x .125	3
6	731-0903D	6" Lower Chute Remote Tilt	1	74	717-0299	Worm Gear LH Double Thread	1
8	784-5711	Chute Bracket	1	75	741-0670	Flange Brg. 1.5 ID x 1.75 OD x .80	2
15	784-5123	Chute Bracket	1	76	736-0266	Flat Washer 1.5 ID x 2.0 OD x .03	2
16	731-1696	Chute Adapter	1	77	717-1425	Worm Gear LH Double Thread (Bronze)	1
17	736-0242	Bell. Washer .345 ID x .88 OD x .06	15				
19	712-3027	Hex Cent. L-Nut 1/4-20 w/ Flange	6	78	738-0275	Worm Gear Shaft	1
20	731-0851A	Chute Flange Keeper	3	79	714-0135	#91 Woodruff Key 1/4 x 3/4 dia	1
23	710-0601	Hex Wash HD Self-Tap Scr 5/16-18 x .75	9	80	719-0349	Gear Housing Half LH	1
				81	710-1260A	Hex Flange Scr. 5/16-18 x .75	7
26	710-0371	Hex Screw 5/16-18 x .75	1	82	712-0429	Hex Ins. L-Nut 5/16-18	12
28	756-0243	1/2" V-Pulley .875 ID x 10.12 OD	1	83	714-0135	#91 Woodruff Key 1/4 x 3/4 dia	1
29	714-0126	#9 Hi-Pro Key 3/16 x 3/4 Dia HT	1	84	736-0250	Flat Washer	4
30	741-0185	Self-Aligning Bearing .875 ID	1	85	741-0494	Flange Bearing	4
31	712-3010	Hex Nut 5/16-18 GD. 5	12	87	710-0891	Shear Bolt 5/16-18 x 1.75	2
32	736-0119	L-Wash 5/16 ID	7	90	05845B	Housing bearing 1.5 Dbl D	2
33	05244A	Bearing Housing	2	91	741-0192	Flange Bearing w/flats	2
34	711-0640	Belt Keeper Studs 3/8-16 x 2.75	5	94	754-0222	V-Belt 1/2 x 44 LG	1
38	710-0451	Carriage Bolt 5/16-18 x .75	16	96	618-0257	Worm Gear Box Ass'y	1
45	684-0093A	33" Snowthrower Hsg. Ass'y	1	98	784-5697	Reversible Skid Shoe	2
46	784-5714	Shave Plate 33"	1	100	705-5210A	RH Spiral Ass'y Serrated - 33"	1
52	710-3168	Carriage Bolt 3/8-16 x 1.00 Gr. 5	2		705-5211A	LH Spiral Ass'y Serrated - 33"	1
53	710-0389	Carriage Bolt 3/8-16 x .75" Lg.	4	101	710-0528	Hex Scr 5/16-18 x 1.25	1
54	784-5710	Gear Housing Support Plate 1 x 3/16	1	102	736-0271	5/16 Sprg Wash	1
56	712-0798	Hex Jam Nut 3/8-16	6	103	736-0169	3/8 Sprg Lock Wash	5
58	715-0118	Spring Spiral Pin Heavy 5/16 dia x 1.7	2	104	618-0281	Brkt Ass'y Brkt	1
59	684-0090	Blower Fan Ass'y Complete	1	105	710-0459A	Scr Hex Cap 3/8-24 x 1.5 GRD 5	1
60	784-5076	Gear housing Support Bracket 1 x 3/16	1	106	711-0677	Adjustment Ferrule	1
				107	712-0116	Hex Ins L-Nut 3/8-24	1
61	721-0325	Barbed Plug	1	108	714-0104	Intern Cot-Pin 5/16 dia	1
63	738-0491	Spiral Axle -33"	1	109	732-0858	Spr Extn .470 dia x 4.75 Lg	1
64	721-0146	Oil Seal 1.50 ID Garlock (76 x 6223)	2	110	736-0174	Wave Washer .66 ID x .88 OD	2
65	719-0348	Gear Housing Half - RH	1	111	736-3008	Fl-Wash SAE .34 x .68	1
67	714-0126	#9 Hi-Pro Key 3/16 x 3/4 dia HT	1	112	738-0281	Shld Scr .625 dia x .170 x .062	2
68	711-1133	Auger Control Shaft	1	113	747-0980	Rod Idler Auger	1
69	716-0111	Snap Ring for .875 dia. shaft	1	114	756-0240	3.0 OD Flat Idler with Flanges	1
70	721-0145	Oil Seal for .875 ID (76 x 6133)	1	115	784-0385	Brkt Idlr Auger	1
71	741-0217	Sleeve Bearing .875 ID	2	116	741-0475	Plastic Bushing .380 ID	1

NOTE: For painted parts, please refer to the list of color codes below. Please add the applicable color code, wherever needed, to the part number to order a replacement part. For instance, if a part, numbered 700-xxxx, is painted yard-man green, the part number to order would be 700-xxxx-0665.

Yard-Man Green: 0665

Yard-Man Yellow: 0674

Powder Black: 0637

Model 993

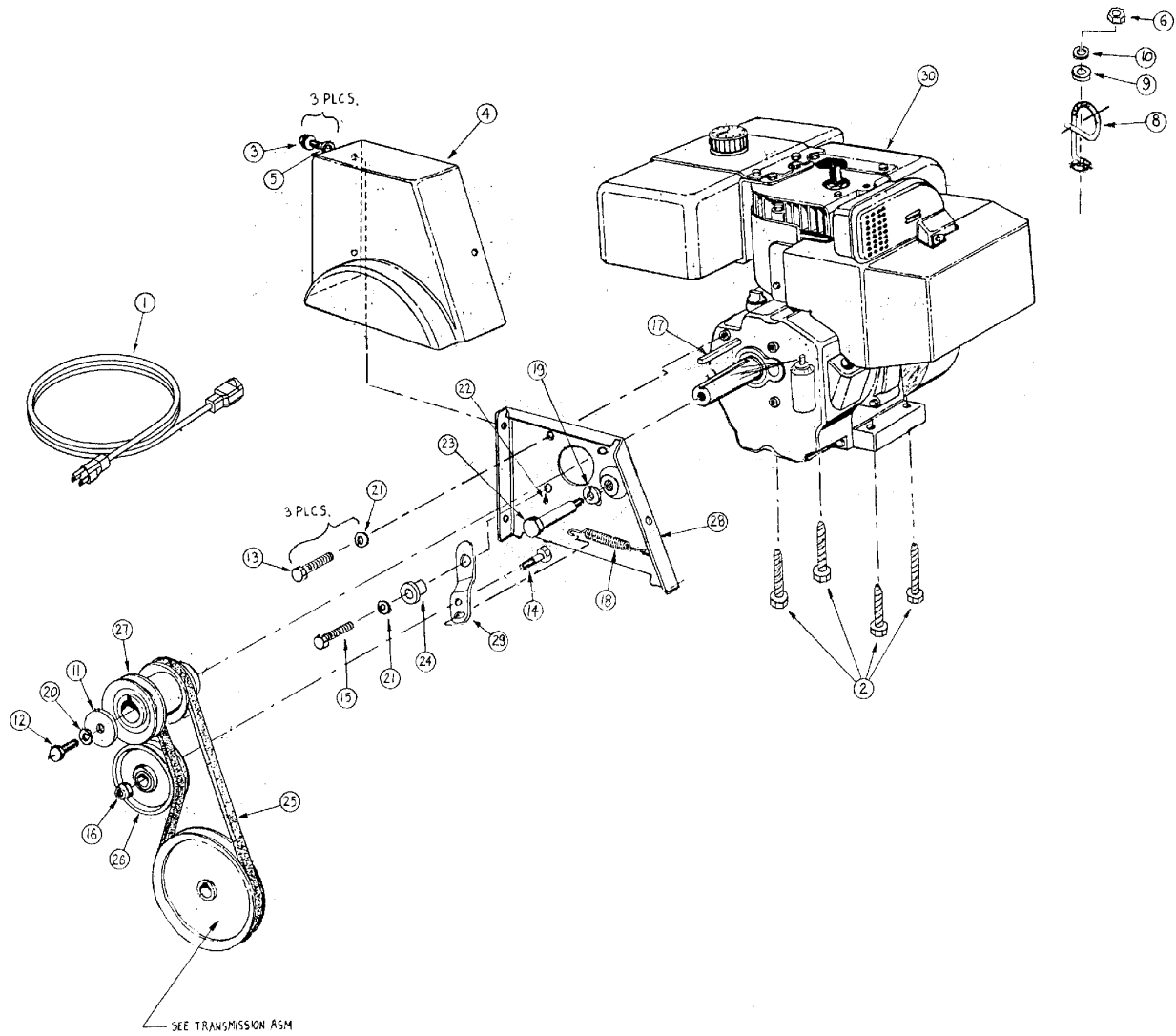

Model 993

Ref. No.	Part No.	Description	Qty.	Ref. No.	Part No.	Description	Qty.
1	629-0071	Extension Cord 10 Ft.	1	17	714-0118	Square Key 1/4 X 1.5	1
2	710-0502A	Hex L-wash Tt Scr 3/8-16 X 1.25	4	18	732-0303	Extension Spring .38 OD X 3.18 L	1
3	710-0607	Hwhd 5/16-18 X 1/2 Thd Roll Zn	3	19	736-0169	L-wash 3/8	1
4	731-0321-1	Belt Cover - Pierced	1	20	736-0217	Lock Washer 3/8 Heavy	1
5	736-0264	Fl-wash .344 ID X .625 OD X .063	3	21	736-0242	Bell Wash .345 ID X .88 OD X .060	4
6	712-3006	Nut 1/4-20 GR B Hex	1	22	737-0157	Grease - Sunaplex 781 - 1/10	1
8	732-0705	Cable Control Wire	1	23	738-0215A	Shoulder Scr .498 Dia X 3.0 Lg	1
9	736-0173	Fl-Wash .28 ID x .74 OD x .063	1	24	748-0234	Shldr Spcr .50 Dia X .14 Shldr	1
10	736-0329	Lock Washer 1/4	1	25	754-0131	3v Belt 35.5 Lg	1
11	07386	Wash .39 ID X 1.75 OD X .175 T	1	26	756-0240	3.0 OD Flat Idler With Flange	1
12	710-0191	Scr Hex Cap 3/8-24 X 1. Gd 8	1	27	756-0241B	Dbl Engine Pulley 3.25 & 2.75	1
13	710-0237	Scr Hex Cap 5/16-24 X .62 Gd 5	3	28	684-0123A	Brkt Asm Cvr Belt 12 HP	1
14	710-0459	Scr Hex Cap 3/8-24 X 1.5 Gd 5	1	29	784-5726	Brkt Idlr Dr	1
15	710-1245	Hhcs 5/16-24 X 7/8 Gr 5	1	30	-	Engine	1
16	712-0116	Hex Ins L-nut 3/8 - 24	1				

IMPORTANT: For a proper working machine, use Factory Approved Parts.

V-BELTS are specially designed to engage and disengage safely. A substitute (non OEM) V-Belt can be dangerous by not disengaging completely

Model 993

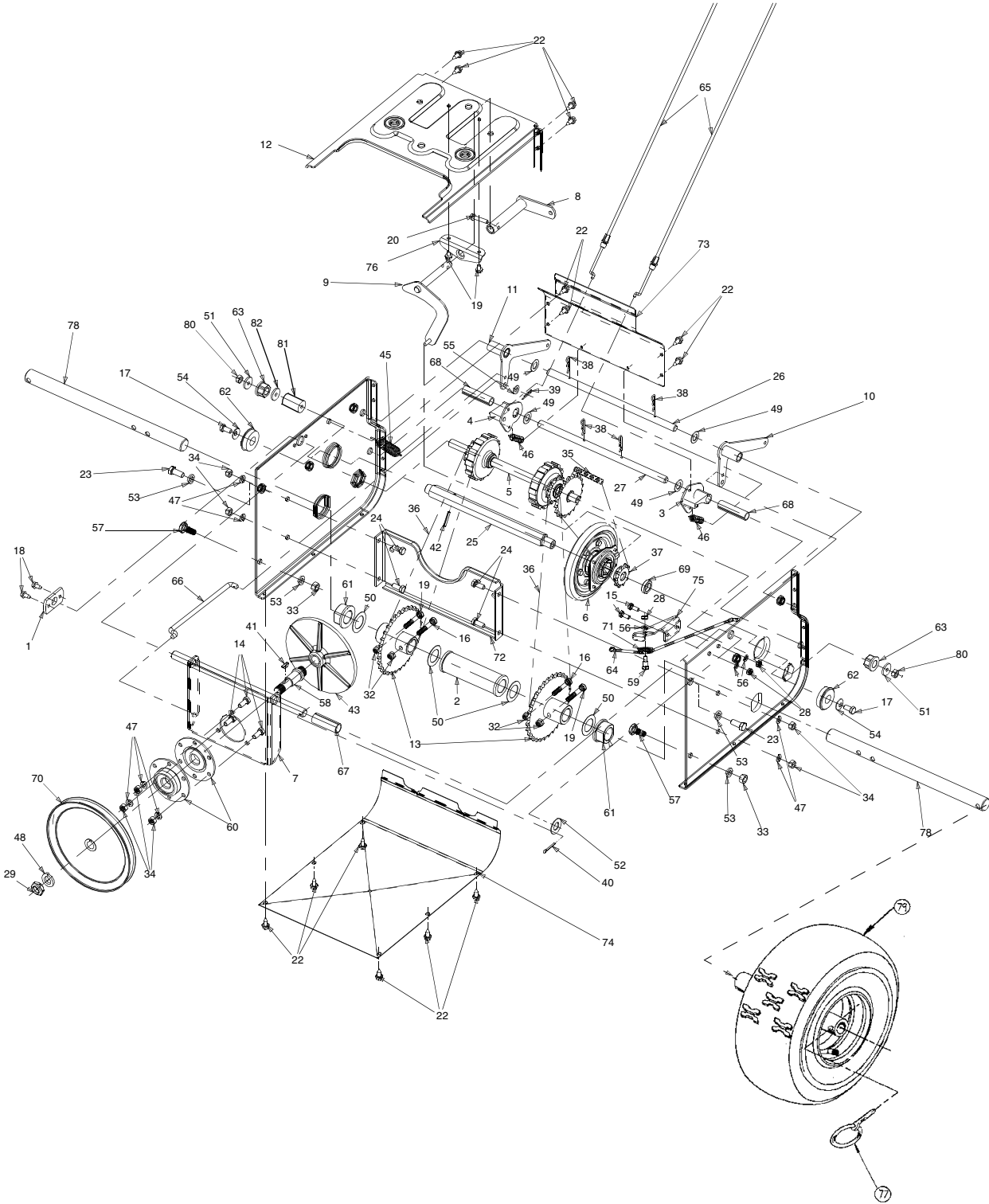

Model 993

Ref. No.	Part No.	Description	Qty.	Ref. No.	Part No.	Description	Qty.
1	05523	Pivot Axle Brkt. .63 Hole - Zinc	1	43	717-0302	Aluminum Drive Plate	1
2	618-0278	Bush Asm slev	1	45	732-0121	Idler Extension Spring	1
3	618-0279	Dogg Asm Dr Lh	1	46	732-0209	Extension Spring	2
4	618-0280	Dogg Asm Dr Rh	1	47	736-0119	Lock Washer 5/16	7
5	618-0282A	Shf Asm Dr	1	48	736-0158	Lock Washer 5/8	1
6	618-0296	Whl Asm Brg 6.0 OD Friction	1	49	736-0160	Wash Fl .531 ID x .930 OD x .05	4
7	684-0115	Brkt Asm Supt Friction Dr	1	50	736-0163	Wash Fl 1.03 ID x 1.62 OD	4
8	684-0116	Arm Asm Shift	1	51	736-0300	Wash Flt 1/4 ID x .930 OD x .12	2
9	684-0117	Shft Asm Rod	1	52	736-0623	Wash Flt .640 ID x 1.24 OD x .06	1
10	684-0118	Brkt Asm Actr Auger	1	53	736-0217	Lock Washer 3/8 Heavy	4
11	684-0119	Brkt Asm Actr Dr	1	54	736-0242	Bell Wash .345 ID x .88 OD	2
12	684-0120	Frm Asm Trans	1	55	736-0275	Fl-wash Sae .34 x .68 .062	1
13	684-0122	Spkt Asm 32t	2	56	736-0329	Lock Washer 1/4	5
14	710-3008	Hex Scr 5/16-18 x .75	3	57	738-0143	Shld Scr .498 Dia x .340	2
15	710-0195	Hhcs 1/4-28 .625 Gr5 std	2	58	738-0279	Drive Plate Spindle	1
16	710-3180	Hex Scr 5/16-18 x 2.00	2	59	738-0924	Scr Shldr .340 D. 1/4 Ab	1
17	710-0538	Hhcs 5/16-18 x .625 Gr5 Lock	2	60	741-0163A	Asm Brg Hsg	2
18	710-0599	Scr TT 1/4-20 x .5 Hxindwsh	4	61	741-0192	Flange Brg Pm W/flts 1.0	2
19	710-3103	Hex Scr 5/16-18 2.00 Lg	2	62	741-0563	Ball Bearing W/snap Ring	2
20	710-0788	Scr Hexwash 1/4-20 x 2.00	1	63	741-0597	Brg Hex Flange x .564 ID	2
22	710-1652	Scr Ab 1/4-14 .625 Hxindwsh	14	64	746-0951	Cb Idlr Auger	1
23	710-3001	Hhcs 3/8-16 x .880 Gr5 Std	2	65	746-0949	Cbl Strg	2
24	710-3008	Scr Cap 5/16-18 x .75 Gr 5	4	66	747-0973	Rod Clu Dr	1
25	711-1191	Shf Dr .875 Hex	1	67	750-1097	Spcr Splt .64 x .77 x 2.1	1
26	711-1193	Shf Sctr	1	68	750-0903	Split Spacer 1/2 x 5/8 x 2.44	2
27	711-1194	Shf Actr Dr	1	69	750-0997	Spcr .675 ID x 1.00 OD x .23	1
28	712-0138	Hex Nut 1/4-28	3	70	756-0344	1/2 V-pulley .62 ID x 7.5	1
29	712-0221	Hex Ins Jam L-nut 5/8-18	1	71	756-0625	Cable Guide Roller	1
32	712-0429	Hex Ins L-nut 5/16-18	4	72	784-0377	Brkt Supt Frm	1
33	712-0798	Hex Nut 3/8-16	2	73	784-0379	Cvr Frm Up	1
34	712-3010	Nut Hex 5/16-18 Gd 5	7	74	784-0380	Cvr Frm Lwr	1
35	713-0284	#41 Chain 1/2 Pitch x 36 L	1	75	784-0384	Brkt Gde Auger Cbl	1
36	713-0286	#420 Chain 1/2 Pitch x 40 L	2	76	784-5590	Shift Bracket Frame	1
37	713-0413	Spkt 10t #41 x .500	1	77	714-0151A	Klik Pin Assy Danuse	2
38	714-0101	Internal Cot-pin 1/2 Dia	4	78	738-0975	Axle 1.0 OD x 14.1 Lg	2
39	714-0104	Intern Cot-pin 5/16 Dia	1	79	734-1593	Cmp. Whl. Assy 16 x 6.5 Snohog	2
40	714-0115	Cotter Pin 1/8 Dia x 1	1	80	712-0116	Hex Jam Nut 3/8-24 Thd.	2
41	714-0388	#61 Hi-pro-key 3/16 x 5/8	1	81	750-1196	Spacer	1
42	715-0249	Spring Pin Roll 5/32	1	82	736-0639	Fl-Washer	1

NOTE: For painted parts, please refer to the list of color codes below. Please add the applicable color code, wherever needed, to the part number to order a replacement part. For instance, if a part, numbered 700-xxxx, is painted yard-man green, the part number to order would be 700-xxxx-0665.

Yard-Man Green: 0665
 Yard-Man Yellow: 0674
 Powder Black: 0637