

HANDLEBAR ASSEMBLY and CONTROL LEVERS

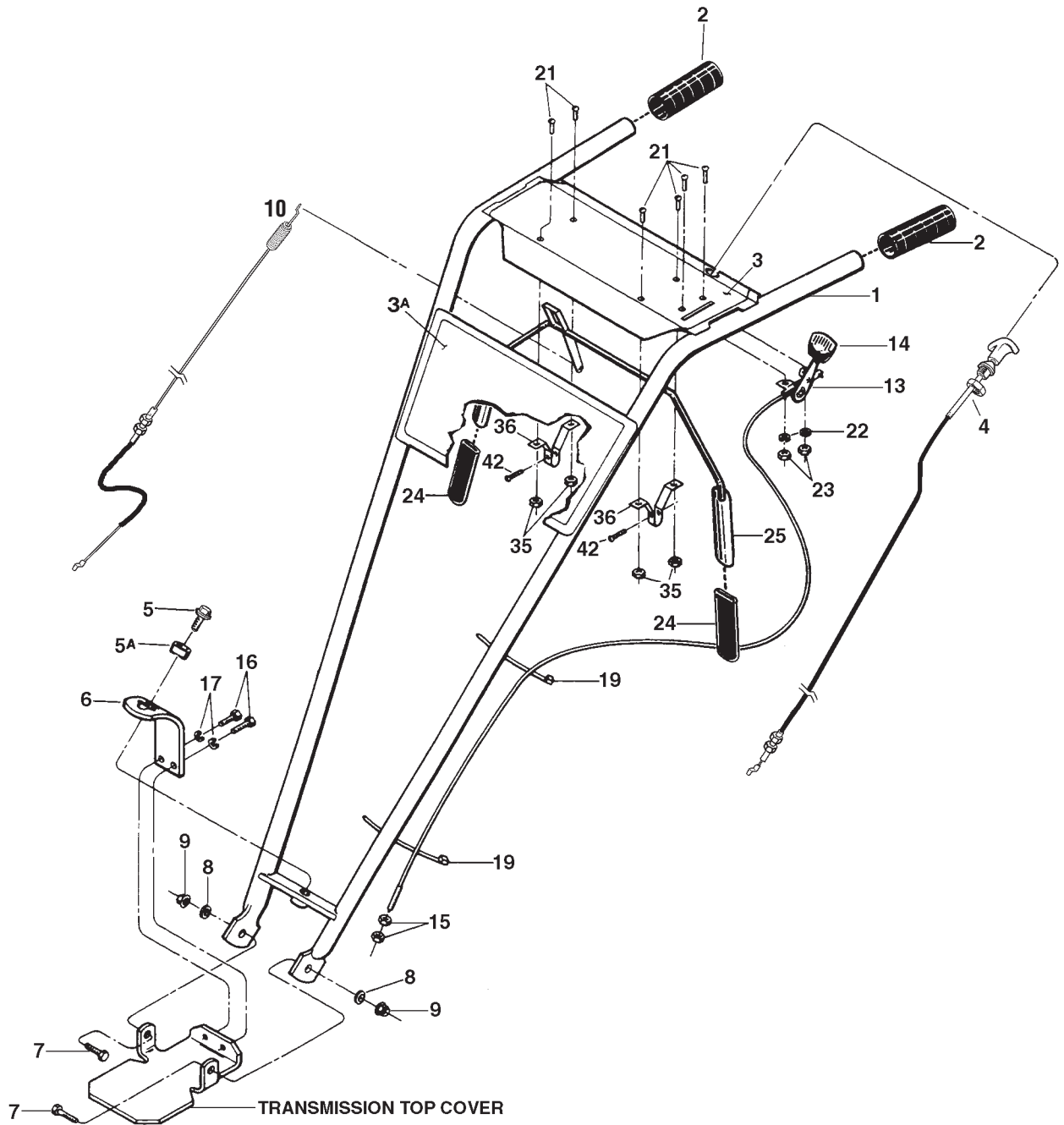

Models 663B, 663E, 665B & E663E

HANDLEBAR ASSEMBLY and CONTROL LEVERS

REF. No.	PART No.	DESCRIPTION	QTY.	REF. No.	PART No.	DESCRIPTION	QTY.
1	1918801	Handlebars.....	1	14	GW-9057	Knob, Wheel Gear Control Lever	1
2	=Grip	2		15	1186211	Hex Nut, 5/16-24.....	2
3	777122624	Decal, Control Panel	1	16	GW-90064	Hex Hd. Screw, 3/8-16 x 5/8*	2
3A	777D09943	Decal, Model Name/Logo (A)	1	17	736-0169	Lockwasher, 3/8.....	2
	777D09940	Decal, Model Name/Logo (C)	1	19	725-0157	Cable Ties, Plastic	2
4	1916784	Reverse Clutch Control Cable.....	1	21	1114748	Round Hd. Screw, #10-32 x 1/2.....	6
5	1186347	Height Adjustment Screw	1	22	1100240	Lockwasher, #10	2
5A	GW-9955	Washer, Keyed	1	23	1186208	Hex Nut, #10-32.....	2
6	1900475001	Bracket, Handlebar Height Adjustment	1	24	GW-9390	Grip.....	2
7	710-0514	Hex Hd. Screw, 3/8-16 x 1*	2	25	1918840	Bail w/ Grips, Forward Clutch Control.	1
8	736-3050	Washer, Plain (flat) 3/8, S.A.E.	2	35	GW-9853	Sems Nut	4
9	712-3000	Hex Locknut, 3/8-16.....	2	36	GW-20806	Bracket, Bail Support	2
10	746-04027	Cable, Forward Clutch Control	1	42	710-0599	Hex Flange Screw, self-tapping, 1/4-20 x 1/2*	2
13	GW-9442	Wheel Gear Control and Cable Assy....	1				

* Specify GRADE 5 if ordering part locally.

- (A)** For Model 663E
(B) For Model E663E
(C) For Model 665B

ENGINE, SUPPORT BRACKETS, PULLEYS, BELTS, BELT COVER

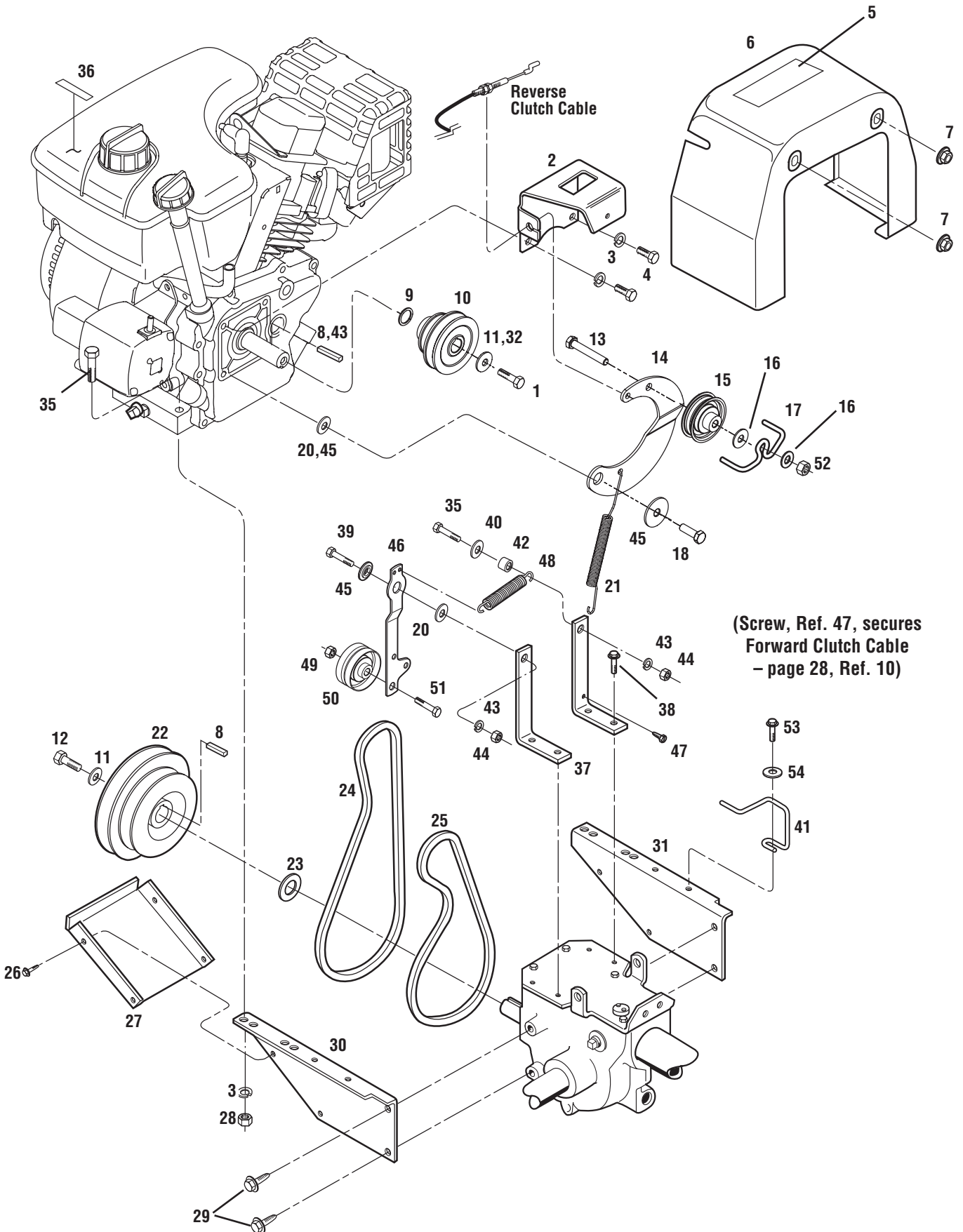

ENGINE, SUPPORT BRACKETS, PULLEYS, BELTS, BELT COVER

REF. No.	PART No.	DESCRIPTION	QTY.	REF. No.	PART No.	DESCRIPTION	QTY.
1	710-0539	Screw, 3/8-24 x 1.75 (A)	1	26	710-04459	Self-tapping Screw, #10-32 x 1/2,.....	4
	710-04458	Screw, 5/16-24 x 1.125 (B).....	1	27	786-04080	Guard, Belts/Pulleys.....	1
2	786-04070	Bracket, Clutch Cable	1	28	712-04063	Hex Flange Nut, 5/16-18.....	4
3	736-0119	Lockwasher-5/16.....	6	29	710-04043	Hex Flange Screw, 5/16-18 x 3/4*	4
4	710-0107	Hex Hd. Screw, 5/16-24 x 1/2	2	30	786-04066	Engine Support Bracket, left side	1
5	777S30651	Decal, Hot Surfaces/Belt Warning	1	31	786-04067	Engine Support Bracket, right side.....	1
6	731-05290	Cover.....	1	32	736-0452	Bell Washer (A).....	1
7	712-3004A	Flange Lock Nut, 5/16-18.....	2	35	710-0395	Hex Hd. Screw, 5/16-18 x 2-1/4	5
8	714-04042	Key, 3/16 x 1-1/2 (B).....	1	36	777I20358	Decal, Stabilization.....	1
9	736-04187	Shim	1	37	786-04277	Mounting Bar	2
10	619-04015	Pulley, Engine Drive (A).....	1	38	710-1260	Hex Flange Screw, 5/16-18 x .75.....	4
	619-04310	Pulley, Engine Drive (B).....	1	39	710-0805	Hex Hd. Screw, 5/16-18 x 1-1/2*	1
11	736-04193	Belleville Washer (B).....	2	40	736-0275	Flat Washer, 5/16'	1
12	710-04458	Hex Hd. Screw, 5/16-24 x 1-1/8	1	41	732-04082	Belt Guide, Pony.....	2
13	710-3103	Hex Hd. Screw, 5/16-18 x 2.....	1	42	750-04160	Pivot Bushing.....	2
14	786-04276	Reverse Idler Arm	1	43	714-04029	Key, .188 x 1.75 (A)	1
15	756-04169	Pulley, Reverse Idler.....	1	44	712-3010	Hex Nut, 5/16-18.....	2
16	736-0159	Flat Washer, 5/16	2	45	748-04087	Washer, Shoulder	2
17	732-04081	Belt Guide, Wire Formed	1	46	786-04275	Idler Arm, Forward Tiller Direction	1
18	710-0117	Hex Head Screw, 5/16-24 x 1.....	1	47	710-04460	Screw, self tapping, #10-24	1
19	748-04087	Washer, Shoulder.....	1	48	732-04078	Spring	1
20	736-3078	Washer, Flat, 1-1/8	3	49	712-3000	Hex Locknut, 5/16-18.....	1
21	732-04077	Spring, Reverse Return.....	1	50	756-04170	Idler Pulley, Forward	1
22	619-04123	Transmission Pulley	1	51	710-0347	Screw, 3/8-16 x 1-3/4	1
23	736-04079	Support Washer.....	1	52	712-0158	Hex Lock Nut, 5/16-18.....	1
24	754-04095	Reverse Clutch Belt.....	1	53	710-04461	Screw, 1/4-20 x 3/4.....	1
25	754-04094	Forward Clutch Belt.....	1	54	736-0463	Flat Washer-1/4.....	1

(A) For Models 663E & E663E

(B) For Model 665B

* Specify GRADE 5 if ordering part locally.

** See your local authorized engine service dealer for engine parts or service. Refer to engine nameplate for engine type and code information.

TRANSMISSION HOUSING, COVERS, SEALS, GASKETS, PLUGS

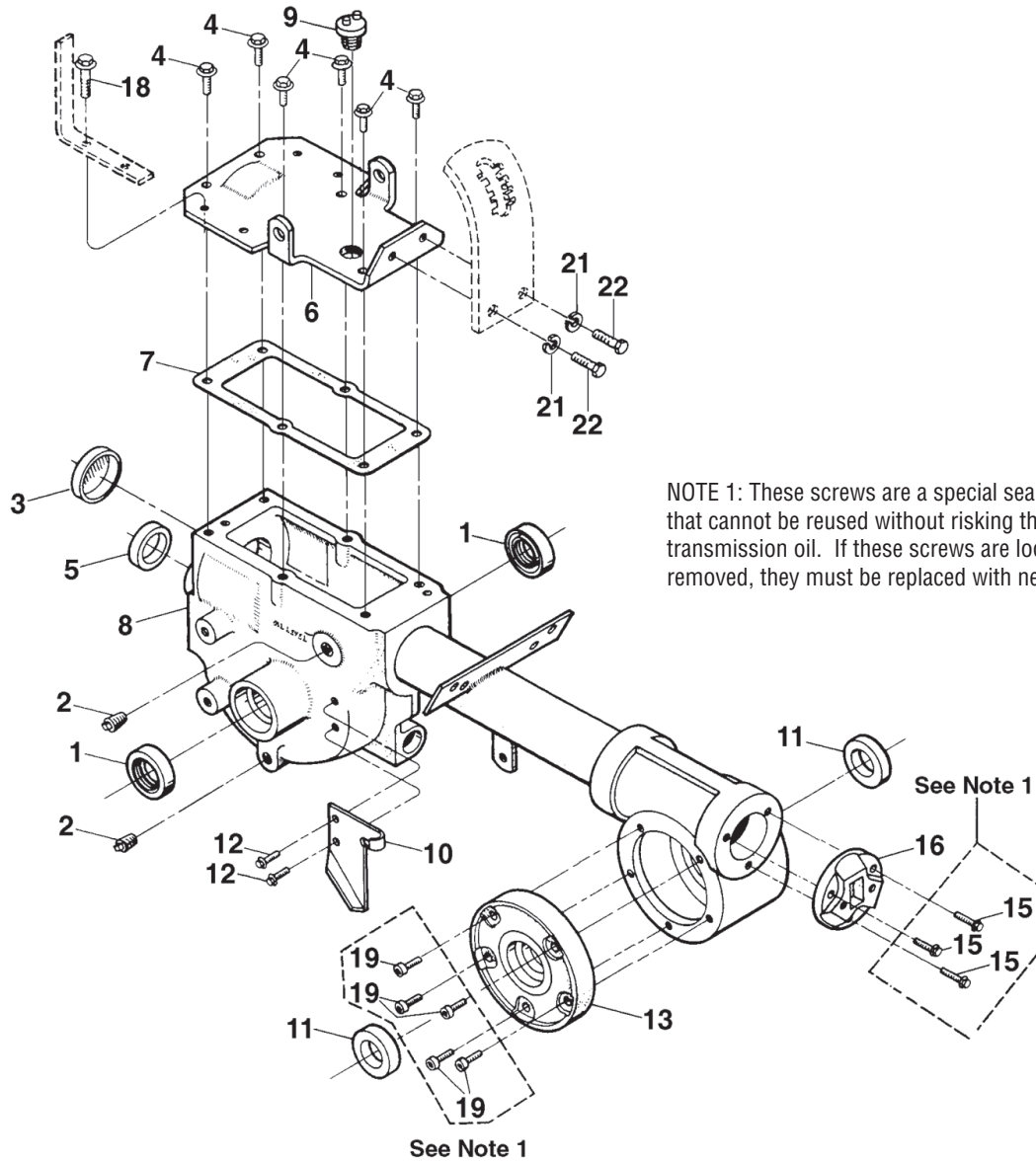

NOTE 1: These screws are a special sealing screw that cannot be reused without risking the loss of transmission oil. If these screws are loosened or removed, they must be replaced with new screws.

REF. No.	PART No.	DESCRIPTION	QTY.	REF. No.	PART No.	DESCRIPTION	QTY.
1	721-04031	Oil Seal (Double Lip), Wheel Shaft.....	2	11	721-04035	Oil Seal, Tiller Shaft.....	2
2	1105620	Pipe Plug, 1/4,	2	12	710-04049	Screw, Hex Flange, 5/16-18 x 5/8".....	2
3	721-04001	Seal, Transmission Bore.....	1	13	GW-20873	Cover, Tiller Housing.....	1
4	710-04043	Hex Flange Screw, 5/16-18 x 3/4*.....	6	15	1915069	Self-Sealing Screw, 1/4-20 x 7/8".....	3
5	721-04044	Oil Seal, Input Pinion Shaft.....	1	16	GW-1115	Rear Bearing Cap.....	1
6	GW-20910	Transmission Cover.....	1	17	GW-1124-2	Gasket, Rear Bearing Cap, .010".....	A/R
7	GW-20694	Gasket, Transmission Top Cover.....	1	18	710-1260A	Hex Flange Screw, 5/16-18 x 3/4*.....	4
8	619-04010	Transmission Case Assy.....	1	19	1915068	Self-Sealing Screw, 1/4-20 x 5/8".....	5
9	GW-9467	Plug.....	1	21	736-0169	Lockwasher, 3/8.....	2
10	1917101001	Mounting Plate, Wheel Clutch Cable ...	1	22	GW-90064	Hex Hd. Screw, 3/8-16 x 5/8*.....	2

* Specify GRADE 5 if ordering part locally.

A/R – As Required

DRIVE SHAFT, INPUT PINION SHAFT and GEAR ASSEMBLIES

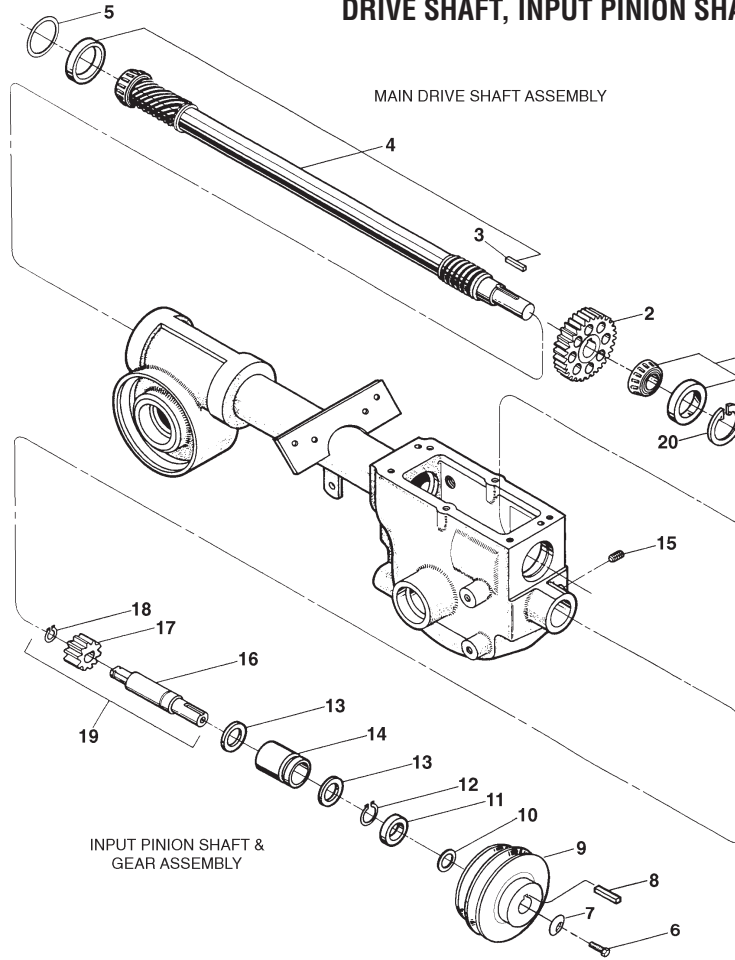

REF. No.	PART No.	DESCRIPTION	QTY.
MAIN DRIVE SHAFT			
1	GW-1714	Bearing, Tapered Roller with Race	1
2	GW-20718	Spur Gear.....	1
3	GW-9301	Key, 3/16 sq. x 1	1
4	GW-20912	Main Drive Shaft (Drive shaft is one-piece with integral, single-lead, work-hardened front worm, and integral, six-lead, work-hardened rear worm. Also includes pressed-on GW-1714 and GW-9301).....	1
5	GW-1224-1	Shim, Rear Bearing Cap, .010" thick (see Note below)	A/R
5	GW-1224-2	Shim, same as above, but .030" thick (see Note)	A/R
5	GW-1224-3	Shim, same as above, but .005" thick (see Note)	A/R
...	GW-1325C	Shim Set (Incl. two GW-1224-1; two 1224-2 and one GW-1224-3)	A/R

REF. No.	PART No.	DESCRIPTION	QTY.
INPUT PINION SHAFT & GEAR ASSEMBLY			
6	710-04458	Hex Hd. Screw, 5/16-24 x 1-1/8*	1
7	736-04193	Washer, Disc Spring (concave surface faces pulley)	1
8	714-04042	Key, 3/16 sq. x 1-1/2	1
9	1916522	Transmission Drive Pulley.....	1
10	736-04079	Support Washer	1
11	721-04044	Oil Seal, Input Pinion Shaft	1
12	1113527	Retaining Ring (external)	1
13	GW-9953	Thrust Washer	2
14	GW-9428	Bushing.....	1
15	GW-9677	Set Screw, 5/16-18 x 3/8*	1
16	GW-20791	Input Pinion (steel shaft).....	1
17	GW-20792	Input Pinion Gear	1
18	GW-9093	Retaining Ring (external) I	1
19	GW-20799	Pinion Assy. (Incl. one each Refs. 16, 17 and 18).....	A/R
20	GW-9517	Retaining Ring (internal).....	1

NOTE: Shim between drive shaft rear bearing and rear bearing cap to achieve 5-to-10 thousandths of an inch (.005-.010) end play on drive shaft.

A/R - As Required

* Specify GRADE 5 if ordering part locally.

WHEEL SHAFT, ECCENTRIC SHAFT and TILLER SHAFT ASSEMBLIES

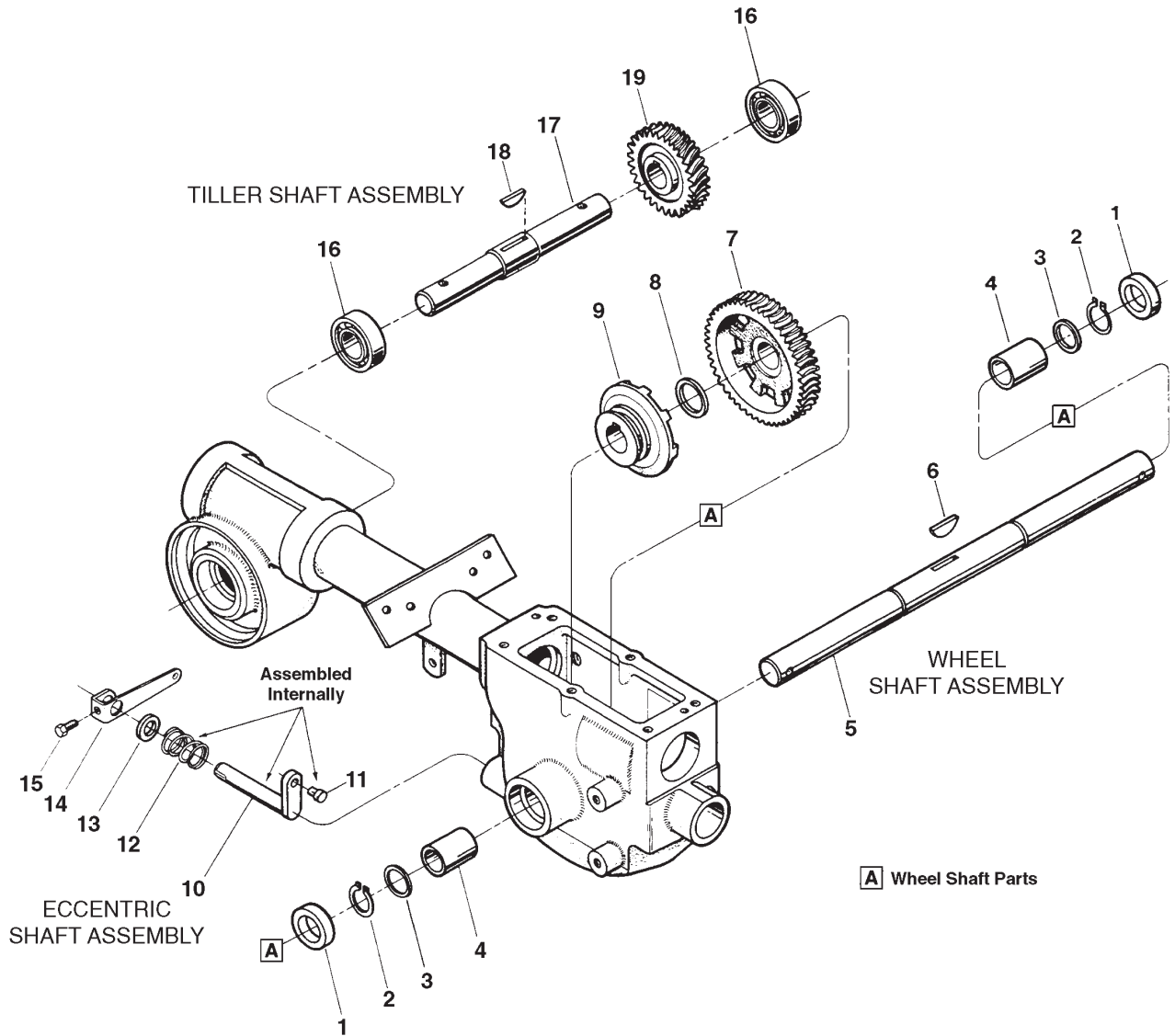

REF. No.	PART No.	DESCRIPTION	QTY.	REF. No.	PART No.	DESCRIPTION	QTY.
1	721-04031	Oil Seal.....	2	9	GW-20712	Wheel Drive Clutch (cast-iron).....	1
2	1909950	Retaining Ring (heavy-duty, external)	2	10	611-04002	Eccentric Shaft.....	1
3	GW-1166-1	Shim, 1-1/64 I.D., .062" thick.....	A/R	11	GW-1442	Pin, Eccentric Shaft.....	1
---	GW-1166-2	Shim, as above, but .030" thick.....	A/R	12	GW-9055	Spring.....	1
---	GW-1166-3	Shim, as above, but .015" thick.....	A/R	13	721-04034	Oil Seal.....	1
---	GW-1166-4	Shim, as above, but .010" thick.....	A/R	14	786-04001	Eccentric Shaft Lever.....	1
4	GW-1086	Bushing.....	2	15	710-3013	Hex Hd. Screw, 1/4-20 x 1/2*.....	1
5	711-04482	Wheel Shaft.....	1	16	741-3037	Ball Bearing.....	2
6	GW-9373	Hi-Pro Key, 1/4 x 1-5/16.....	1	17	711-04080	Tiller Shaft.....	1
7	GW-20914	Wheel Drive Worm Gear (cast-iron).....	1	18	GW-1104	Woodruff Key, 1/4 x 1-1/4.....	1
8	GW-9935	Shim (between key and gear), 1.016 I.D. x 1.468 O.D. x .062 Thick.....	1	19	GW-20913	Tiller Drive Worm Gear (bronze).....	1

* Specify GRADE 5 if ordering part locally.

A/R - As Required

BOLO TINES, WHEELS

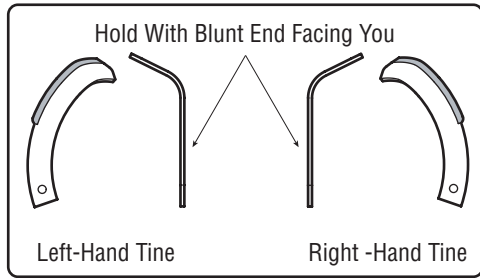

NOTE 1: Custom Tilling Tines are available for your tiller. These are special hard-faced tines that are thicker than standard tines.

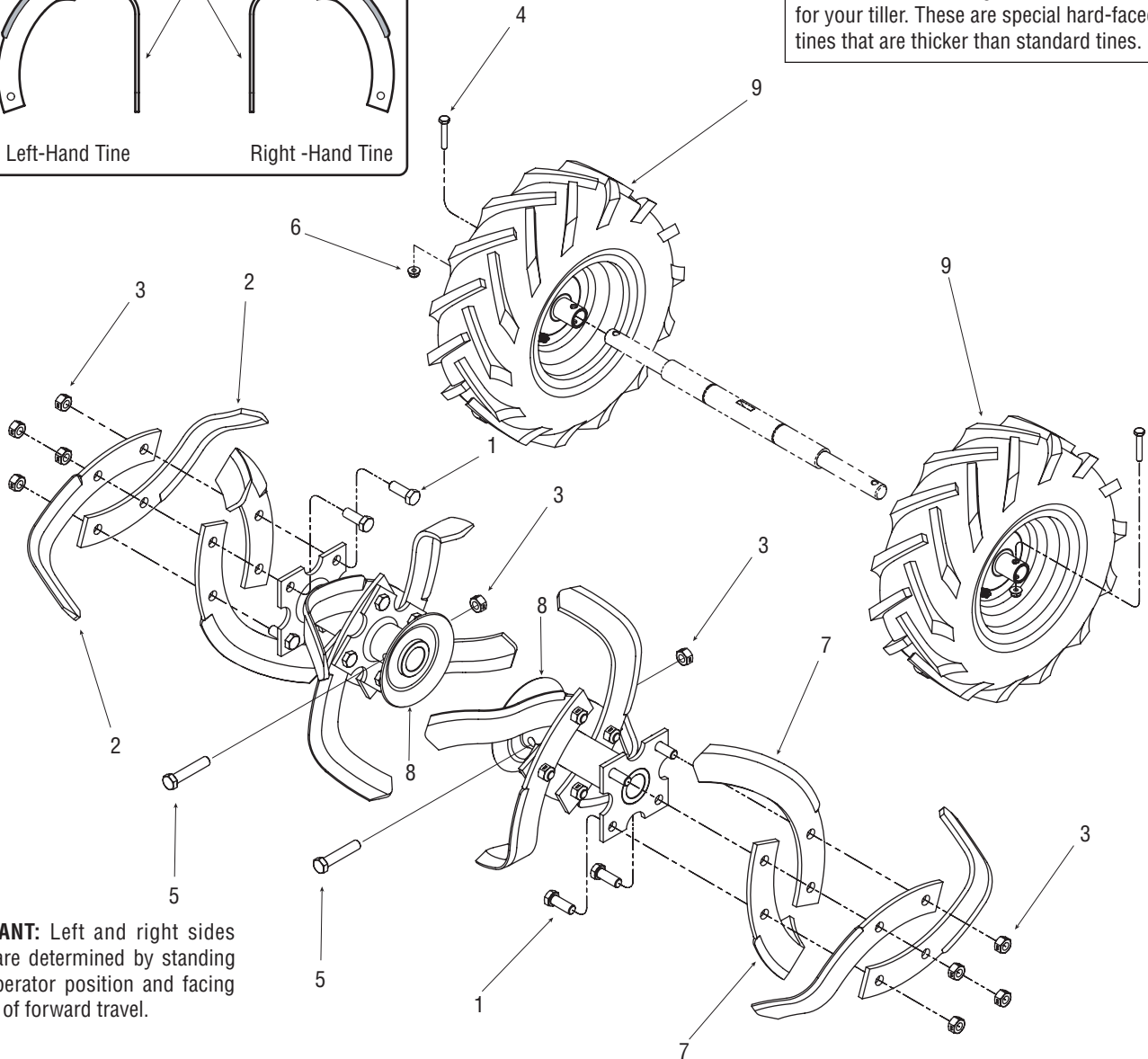

IMPORTANT: Left and right sides of tiller are determined by standing in the operator position and facing direction of forward travel.

REF. No.	PART No.	DESCRIPTION	QTY.	REF. No.	PART No.	DESCRIPTION	QTY.
1	710-0514	Hex Hd. Screw, 3/8-16 x 1*	16	--	GW-2475-1	Custom Tilling Bolo Tine, Left hand tine (see Note 1 above)	8
2	742-04119	Bolo Tine-single. Left hand tine	8	--	GW-2475-2	Custom Tilling Bolo Tine, Right hand tine (see Note 1 above)	8
3	712-3000	Hex Locknut, 3/8-16	18	--	GW-10802	Custom Tilling Bolo Tine Replacement Set (Incl. eight ea. right hand and left hand custom tines, and sixteen each of Refs. 1 and 3)	1
4	710-0606	Hex Hd. Screw, 1/4-20 x 1.5	2	9	634-04232	Wheel Assembly, 13 x 5 x 6	2
5	710-3096	Hex Hd. Screw, 3/8-16 x 2, Grade 8	2				
6	712-04064	Hex Locknut, Flange, 1/4-20	2				
7	742-04118	Bolo Tine-single. Right hand tine	8				
8	686-04067	Tine Holder. For left and right sides	2				
--	1901118	Bolo Tine Replacement Set (Incl. eight ea. right hand and left hand tines, and sixteen ea. Refs. 1 and 3)	1				

* Specify GRADE 5 if ordering part locally.

BUMPER ATTACHMENT

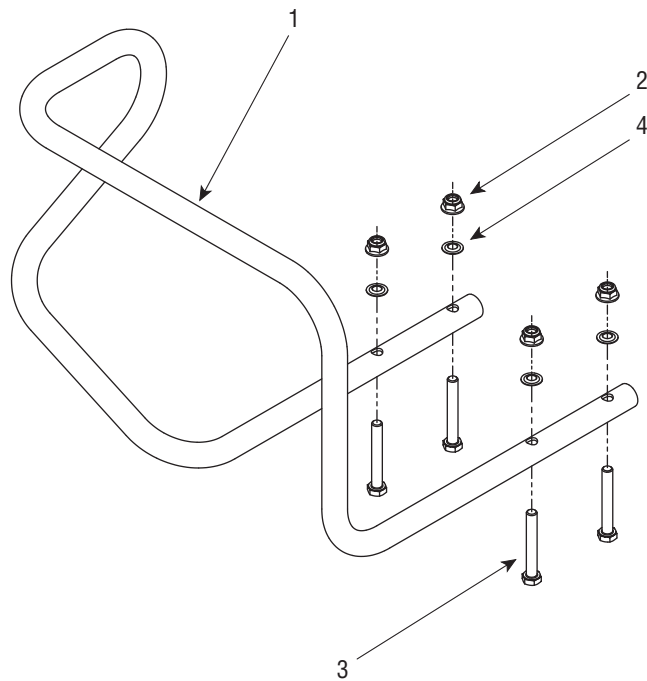

REF No.	PART No.	DESCRIPTION	QTY.
1	749-04193	Bumper	1
2	712-04063	Lock Nut-Hex, Nylon, 5/16-18*	4
3	710-0395	Screw-hex hd., 5/16-18 x 2-1/4.....	4
4	736-0119	Lockwasher-5/16.....	4
5	712-04063	Lock Nut-Hex, Nylon, 5/16-18*	4

HOOD, BRACKET and DEPTH REGULATOR

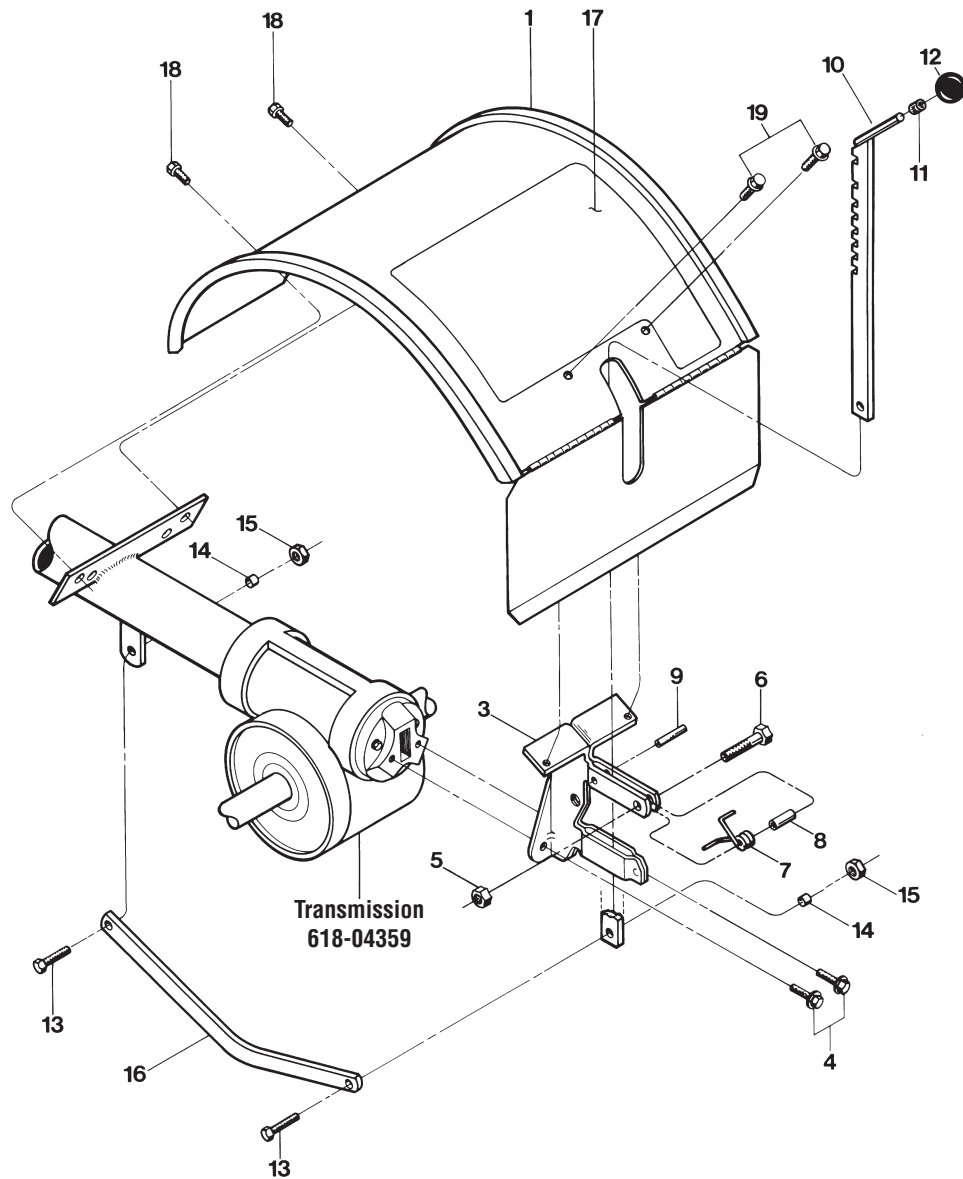

REF. No.	PART No.	DESCRIPTION	QTY.	REF. No.	PART No.	DESCRIPTION	QTY.
1	686-04078	Tine Hood.....	1	11	GW-9120	Retaining Ring (tolerance ring).....	1
2	710-0169	Lockwasher, 3/8.....	2	12	GW-9119	Knob, Depth Regulator (Incl. Ref. 11).	1
3	GW-1925	Bracket-hood & depth regulator.....	1	13	710-3005	Hex Hd. Screw, 3/8-16 x 1-1/4*.....	2
4	710-04049	Hex Flange Screw, 5/16-18 x 5/8*.....	2	14	GW-1113-1	Bushing, Drag Bar.....	2
5	712-04064	Hex Locknut, 1/4-20.....	1	15	712-04065	Hex Nut, 3/8-16.....	2
6	710-0597	Hex Hd. Screw, 1/4-20 x 1*.....	1	16	GW-20775	Drag Bar.....	1
7	732-04320	Spring.....	1	17	777S30649	Decal, operating instructions.....	1
8	750-04556	Spacer.....	1	18	710-0759	Hex Hd. Screw, self-tapping, 5/16-18 x 5/8*.....	2
9	715-04034	Roll Pin (spiral), 1/4 x 1.....	1	19	710-0599	Hex Flange Screw, self-tapping, 1/4-20 x 1/2*.....	2
10	GW-1117A	Depth Adjustment Bar Assembly (Incl. Refs. 11 and 12).....	1				

* Specify GRADE 5 if ordering part locally.

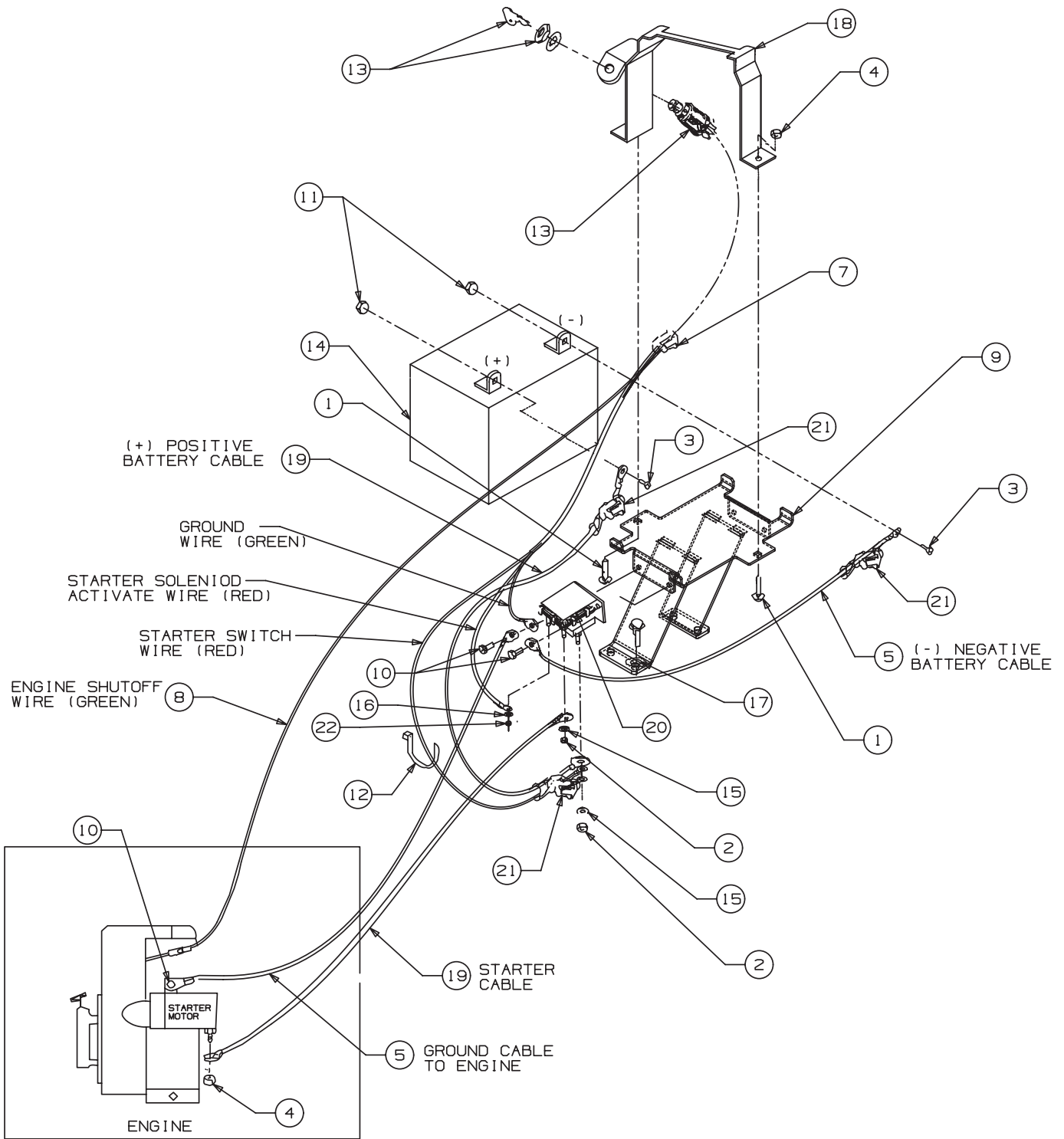

ELECTRIC START ASSEMBLY

REF. No.	PART No.	DESCRIPTION	QTY.	REF. No.	PART No.	DESCRIPTION	QTY.
1	1186073	Carriage Screw, 1/4-20 x 1.25.....	2	9	686-04024	Battery Bracket Assembly, Pony.....	1
2	1186211	Hex Nut, 5/16-24.....	2	10	710-0599	Self-tapping Screw, 1/4-20 x .5.....	3
3	1186309	Flange Screw, 1/4-20 x .625.....	2	11	712-3006	Hex Nut, 1/4-20.....	2
4	1186389	Hex Locknut, 1/4-20.....	2	12	725-0157	Cable Tie	1
5	1901202	Cable (ground wire to starter motor bracket)	2	13	725-0267B	Ignition Switch.....	1
7	725-04346	Wire Harness Assy. (available as complete assembly only). Incl. wire assy. w/connector to large solenoid stud (red wire); wire assy. w/connector to small solenoid stud (red wire); wire assy. w/connector to solenoid grounding screw (red wire); wire assy w/connector to engine ground shut-off (green wire); plastic protector tube; wire terminal.....	1	14	725-1706A	Battery, 270 CCA.....	1
8	1917262	Ground Wire Assy. (shut off)	1	15	736-0119	Lock Washer 5/16.....	2
				16	736-0147	Lock Washer, #10	1
				17	736-0607	External Lock Washer, 5/16.....	2
				18	GW-2614	Keyswitch Clamp.....	1
				19	GW-96510	Cable (solenoid to starter motor)	1
				20	GW-96514	Solenoid (Incl. nuts and washers for cables and wires).....	1
				21	GW-97020	Boot, Insulating.....	2
				22	GW-9853	Hex Locknut, #10-32.....	1
				—	777S30648	Label, Ignition Switch.....	1