

SECTION 8: PARTS LIST FOR MODEL SERIES 410

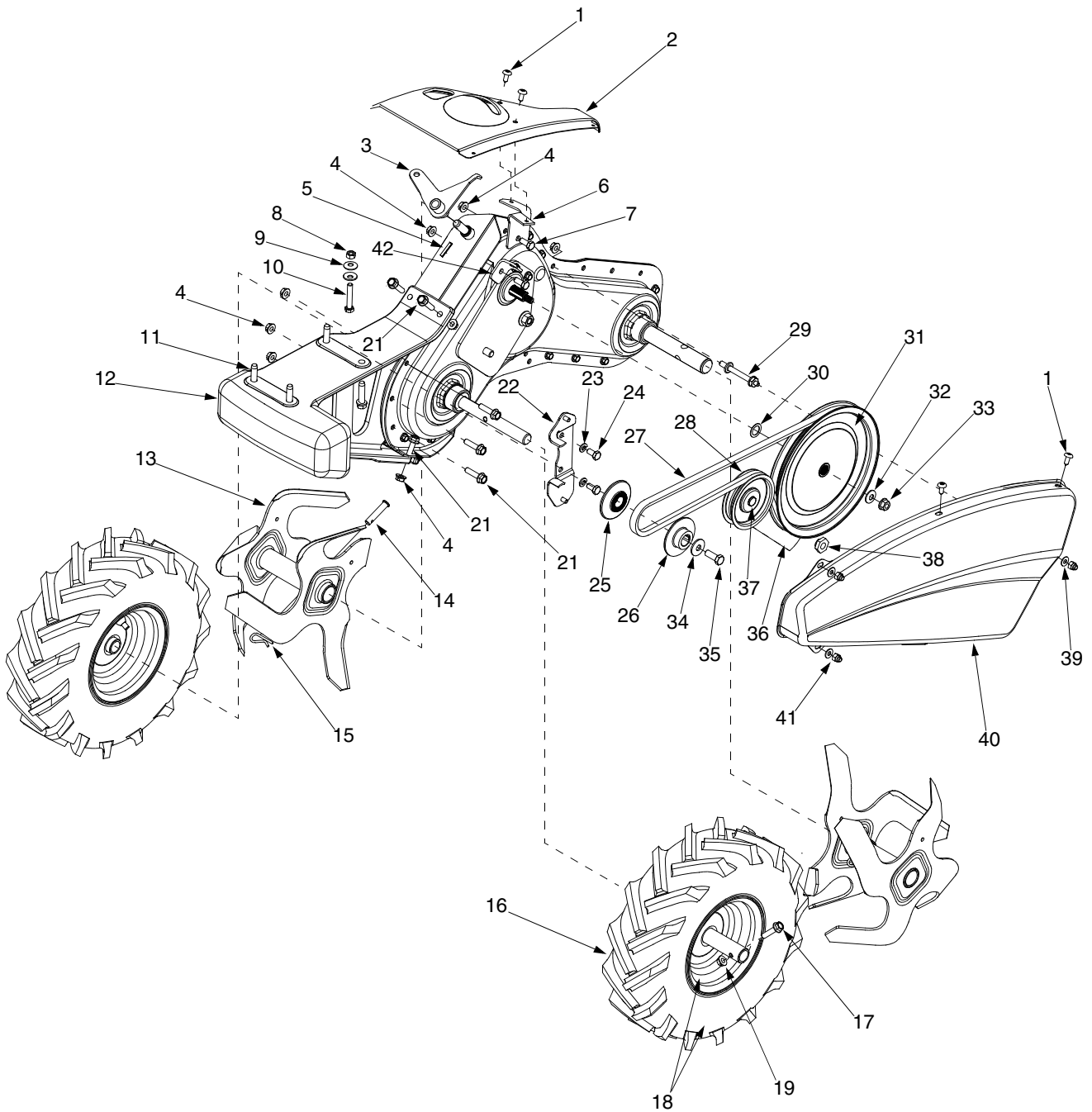

Model Series 410

Ref. No.	Part No.	Part Description	Ref. No.	Part No.	Part Description
1.	710-1017	Hex Screw 1/4-20 x.625	22.	686-0031A	Belt Keeper Bracket Ass'y
2.	786-0168	Shift Cover - Tecumseh	23.	736-0119	Lock Washer 5/16
3.	686-0095	Crank Shift Assembly	24.	710-0237	Hex Cap Screw 5/16-24 x.625
4.	712-04063	Hex Lock Nut 5/16-18	25.	756-0971	Inner Pulley Half
5.	715-0120	Spiral Pin	26.	756-0972	Outer Pulley Half
6.	786-0117	Shift Cover Mounting Bracket	27.	754-0438	V-Belt
7.	710-3008	Hex Cap Screw 5/16-18 x.75	28.	756-0405	Flat Idler
8.	712-3010	Hex Nut 5/16-18	29.	738-0899	Bolt 5/16-18 x 1/4-28 x 2.35
9.	736-0242	Bell Washer.340 ID x.872 OD	30.	736-0256	Flat Washer.635 ID x.930 OD
10.	710-3180	Hex Cap Screw 5/16-18 x 1.75	31.	756-0634	Flat Pulley
11.	710-1007	Hex Washer Screw 3/8-16 x 1.5	32.	736-0105	Spring Washer.401 ID x.870 OD
12.	619-0009A	Frame Counterweight	33.	712-0379	Flange Lock Nut 3/8-24
13.	642-0015	Tine Assembly - LH	34.	736-0452	Bell Washer.396 ID x 1.140 OD
	642-0016	Tine Assembly - RH	35.	710-0152	Hex Cap Screw 3/8-24 x 1.0
14.	711-0415	Clevis Pin	36.	786-0080	Idler Bracket
15.	714-0149B	Cotter Pin	37.	710-0723	Hex Cap Screw 3/8-16 x 1.25
16.	634-04233	Complete Wheel Ass'y - RH (14")	38.	738-0876	Shoulder Nut 7/16-20
17.	710-0606	Hex Head Screw 1/4-20	39.	736-3020	Flat Washer.271 ID x.630 OD
18.	734-1796	Tire Only (14")	40.	786-0100	Belt Cover
	634-04218	Rim Only (6.0 x 3.25)	41.	712-0392	Hex Lock Nut 1/4
19.	712-04064	Flange Lock Nut 1/4-20	42.	786-0107	Cable Bracket
21.	710-1090	Flange Screw 5/16-18 x 1.25			

IMPORTANT: For a proper working machine, use Factory Approved Parts.

V-BELTS are specially designed to engage and disengage safely. A substitute (non OEM) V-Belt can be dangerous by not disengaging completely.

Model Series 410

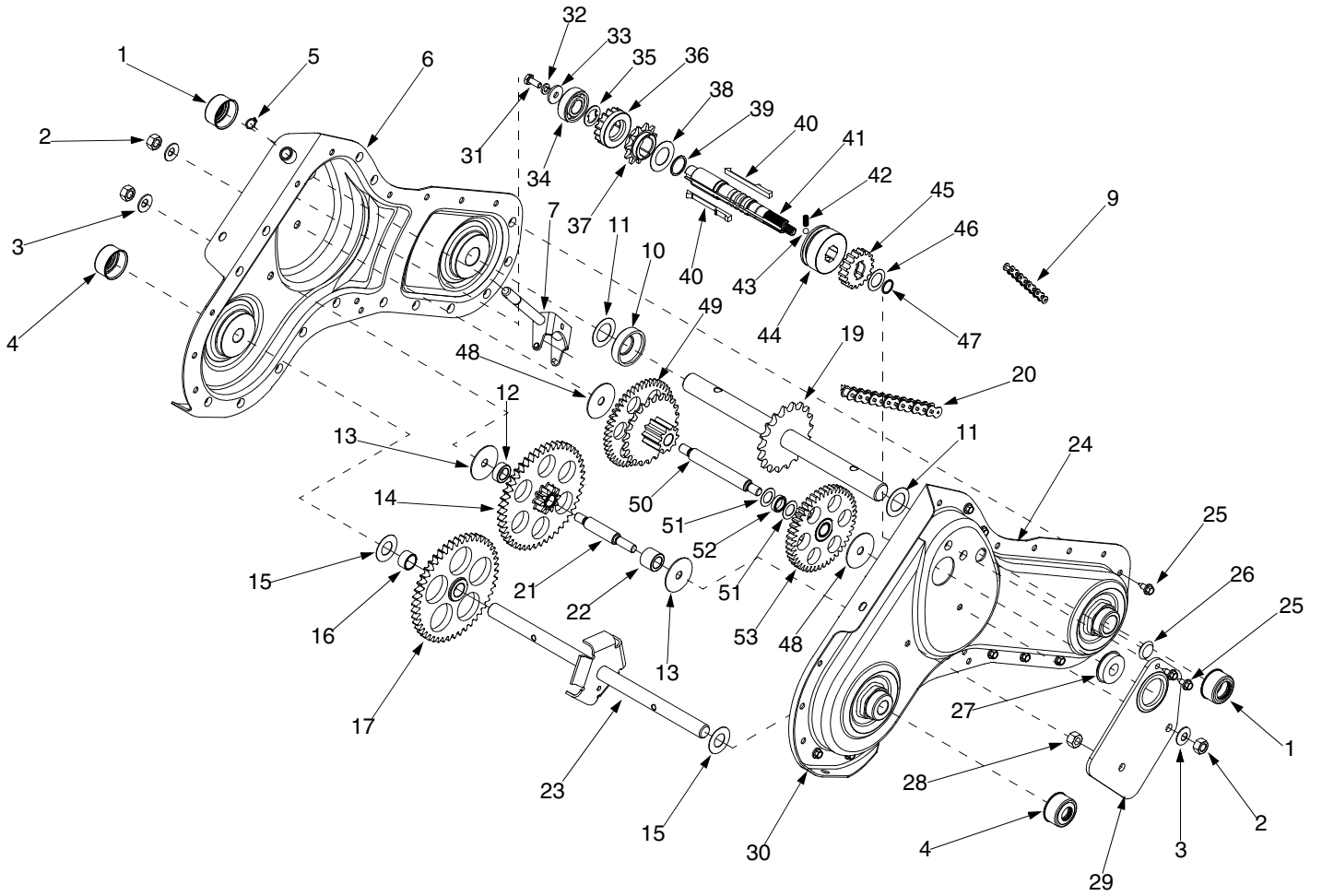

Model Series 410

Ref. No.	Part No.	Part Description	Ref. No.	Part No.	Part Description
1.	721-0378	Shaft Seal 1.0 Dia	29.	786-0086	Reinforcement Bracket
2.	712-0378	Hex Nut 7/16-20	30.	721-0295	Chain Case Gasket
3.	736-0407	Bell Washer.45 ID x 1.0 OD	31.	710-0258	Hex Cap Screw 1/4-20 x.625
4.	721-0379	Shaft Seal.75 Dia	32.	736-0329	Lock Washer 1/4
5.	716-0865	Snap Ring.50 Dia	33.	736-0512	Flat Washer.281 ID x.875 OD
6.	686-0038	Gear Case Assembly - RH Half	34.	741-0124	Ball Bearing
7.	618-0245B	Shift Assembly	35.	736-0541	Flat Washer
9.	713-0233	Chain - #41 1/2" Pitch x 30 Links	36.	717-1451A	Spur Gear 16T
10.	750-0570	Space 1.0 ID x 2.0 OD	37.	713-0435	Sprocket 11T #41 Chain
11.	736-0163	Thrust Washer 1.03 ID x 1.62 OD	38.	736-0265	Flat Washer.88 ID x 1.50 OD
12.	750-0936	Spacer.635 ID x 1.0 OD	39.	716-0235	Retainer Ring
13.	736-0518	Thrust Washer.445 ID x 1.92 OD	40.	718-0237	Clutch Key
14.	617-0004	Idler Gear Assembly	41.	711-1087	Drive Shaft
15.	736-0351	Flat Washer.760 ID x 1.50 OD	42.	732-0863	Compression Spring
16.	750-0938	Spacer.735 ID x.886 OD	43.	741-0862	Detent Ball
17.	717-1458	Spur Gear 46T	44.	718-0234	Clutch Collar
19.	611-0021	Tine Shaft Assembly 18T	45.	717-1409	Spur Gear 17T
20.	713-0226	Chain - #50 5/8" Pitch x 52 Links	46.	736-0442	Flat Washer.69 ID x 1.06 OD
21.	738-0885	Jack Shaft 5/8 Dia. X. 2.06 Lg	47.	732-0614	Wire Ring
22.	750-0935	Spacer.635 ID x 1.0 OD	48.	736-0518	Thrust Washer.445 ID x 1.9 OD
23.	611-04073	Wheel Shift Assembly	49.	611-0016	Intermediate Gear Assembly
24.	686-0039	Gear Case Assembly - LH Half	50.	738-0884	Jack Shaft
25.	710-0896	Hex Washer Screw 1/4-14 x.625	51.	736-0336	Flat Washer.625 ID x 1.0 OD
26.	726-0331	Plug	52.	750-0931	Spacer.635 ID x.86 OD
27.	741-0563	Ball Bearing w/Snap Ring	53.	617-0003	Tine Drive Assembly
28.	712-3067	Hex Patch L-Nut 7/16-20			

Model Series 410

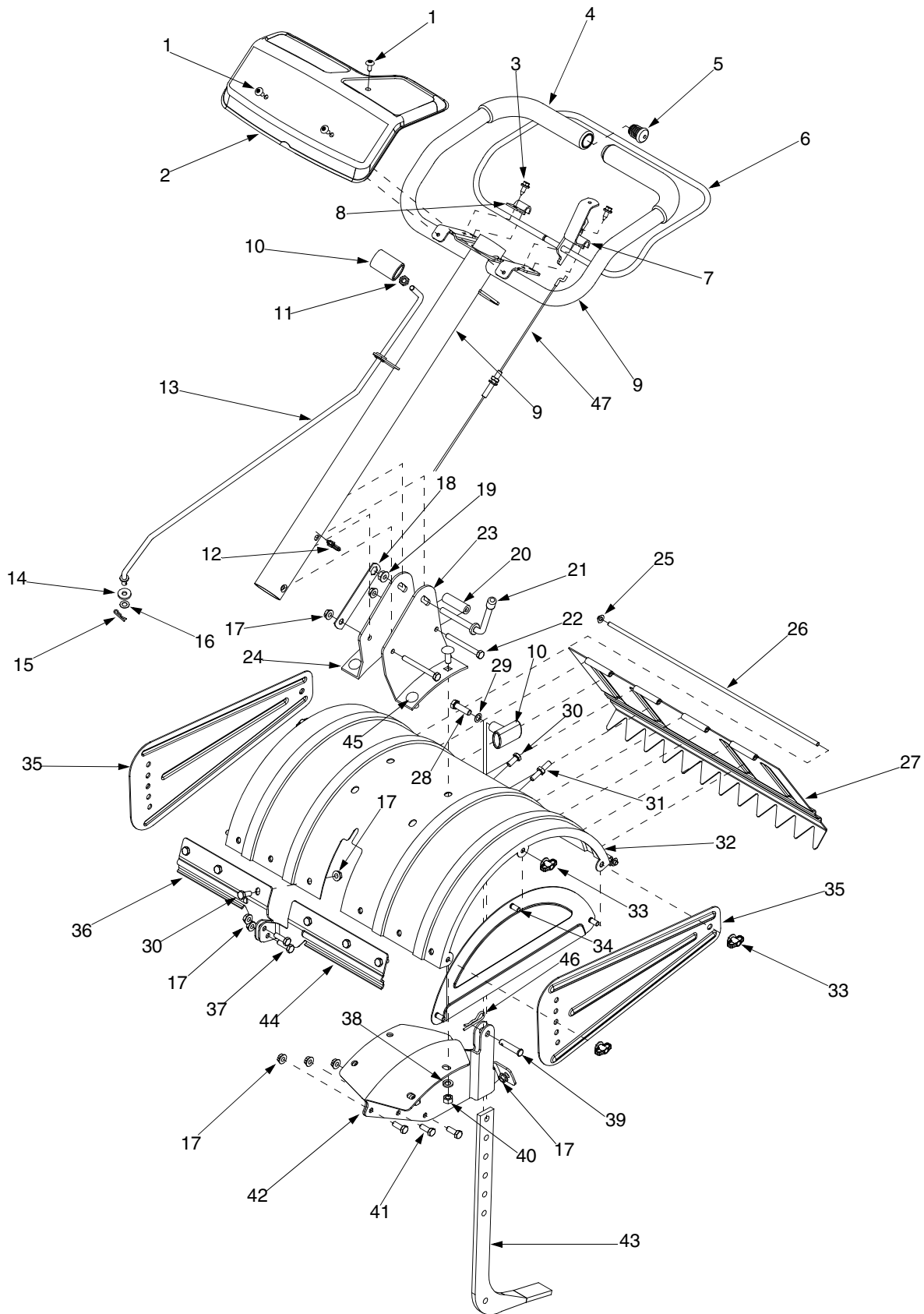

Model Series 410

Ref. No.	Part No.	Part Description	Ref. No.	Part No.	Part Description
1.	710-1017	Tap Screw 1/4-14 x.625	25.	726-0106	Cap Nut
2.	786-0131	Handle Cover w/o Throttle	26.	747-0432	Rod
3.	710-0896	Hex Washer Screw 1/4-14 x.625	27.	786-0113	Rear Tine Shield Flap
4.	720-0278A	Foam Grip	28.	710-3005	Hex Cap Screw 3/8-16 x 1.25
5.	735-0246	End Plug	29.	736-0117	Flat Washer.375 ID x.620 OD
6.	647-0014	Clutch Control Assembly	30.	710-3008	Hex Cap Screw 5/16-18 x.75
7.	786-0118	Return Bracket - LH	31.	738-0849	Hex Screw 5/16-18 x.75
8.	786-0098	Return Bracket - RH	32.	786-0085	Tine Shield
9.	649-0017	Handle Assembly	33.	712-0421	Wing Nut
10.	720-0210A	Knob	34.	686-0044A	End Cover Assembly
11.	712-3008	Jam Nut 3/8-16	35.	786-0090	Side Shield
12.	726-0330	Cable Clip	36.	786-0076	Shield Bracket RH
13.	747-0902	Shift Control	37.	710-0376	Hex Cap Screw 5/16-18 x 1.0
14.	735-0127	Rubber Washer.33 ID x.87 OD	38.	736-0169	Lock Washer 3/8
15.	714-0104	Cotter Pin	39.	711-0415	Clevis Pin
16.	736-0204	Flat Washer.344 ID x.62 OD	40.	712-3017	Hex Nut 3/8-16
17.	712-04063	Hex Flange Lock Nut 5/16-18	41.	710-3038	Hex Cap Screw 5/16-18 x.875
18.	784-0191	Retainer Bracket	42.	686-0043A	Tine Shield Bracket Assembly
19.	712-0379	Flange Lock Nut 3/8-24	43.	786-0120	Depth Stake
20.	750-0885A	Spacer.322 ID x.625 OD	44.	786-0077	Shield Bracket - LH
21.	784-0190	Handle Adjustment Crank	45.	710-3097	Carriage Bolt 3/8-16 x 1.0
22.	710-0189	Hex Screw 5/16-18 x 3.0	46.	714-0147	Cotter Pin
23.	786-0109	Handle Mounting Bracket - LH	47.	746-0916	Clutch Cable
24.	786-0108	Handle Mounting Bracket - RH			

NOTE: For **painted parts**, please refer to the list of color codes below. Please add the applicable color code, wherever needed, to the part number to order a replacement part. For instance, if a part numbered 700-xxxx is painted Oyster Gray, the part number to order would be 700-xxxx-0662.

Black — 0691; Black, Powder — 0637; Blue, Midnight — 0667; Charcoal — 0483; Grey — 0648;
 Grey, Oyster — 0662; Orange — 0606; Red — 0650; Red, MTD — 0638; Silver — 0629; Yellow — 0674.