

TECUMSEH

TECHNICIAN'S HANDBOOK

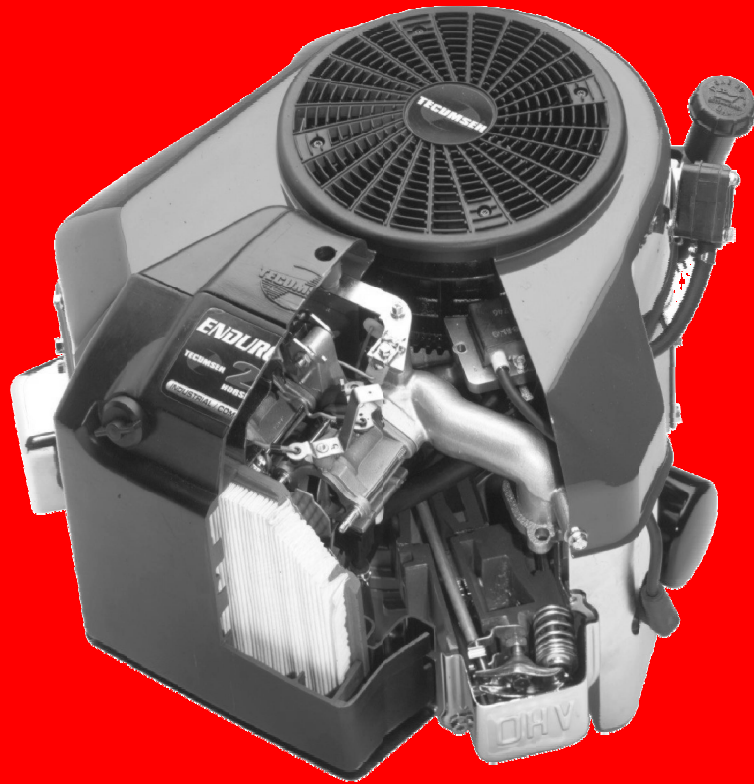

V-TWIN
ENGINE



TABLE OF CONTENTS

CHAPTER 1. GENERAL INFORMATION

CHAPTER 2. AIR CLEANERS

CHAPTER 3. CARBURETORS AND FUEL SYSTEMS

CHAPTER 4. GOVERNORS AND LINKAGE

CHAPTER 5. ELECTRICAL SYSTEMS

CHAPTER 6. IGNITION

CHAPTER 7. INTERNAL ENGINE AND DISASSEMBLY

CHAPTER 8. ENGINE ASSEMBLY

CHAPTER 9. TROUBLESHOOTING AND TESTING

CHAPTER 10. ENGINE SPECIFICATIONS

Copyright © 2000 by Tecumseh Products Company

All rights reserved. No part of this book may be reproduced or transmitted, in any form or by any means, electronic or mechanical, including photocopying, recording or by any information storage and retrieval system, without permission in writing from Tecumseh Products Company Training Department Manager.

TABLE OF CONTENTS

(by subject)

GENERAL INFORMATION

	Page
Engine Identification	1-1
Interpretation of Engine Identification	1-1
Short Blocks	1-2
Fuels	1-2
Engine Oil	1-3
Basic Tune-Up Procedure	1-4
Storage	1-4

AIR CLEANERS

General Information	2-1
Operation	2-1
Components	2-1
Troubleshooting and Testing	2-1
Service	2-2

CARBURETORS AND FUEL SYSTEMS

General Information	3-1
Float Style Carburetors	3-1
Operational Circuits Series 7 Carburetor	3-1
Testing	3-3
Carburetor Disassembly Procedure	3-5
Inspection	3-7
Carburetor Re-Assembly	3-7
Throttle Shaft and Plate	3-7
Choke Shaft and Plate	3-8
Fuel Bowl Assembly	3-8
Impulse Fuel Pumps	3-9
Impulse Fuel Pump Service	3-10

GOVERNORS AND LINKAGE

General Information	4-1
Operation	4-1
Troubleshooting	4-1
Engine Speed Adjustments	4-1
Engine Overspeed	4-2
Engine Surging	4-2
Governor Service	
Static Adjustment - Governor	4-2
Governor Gear and Shaft Service	4-3
Governor Shaft Replacement	4-3

TABLE OF CONTENTS (continued)

	Page
Speed Controls and Linkage	4-3
Synchronizing the Carburetors	4-4
Choke Synchronization	4-5
 ELECTRICAL SYSTEMS	
General Information	5-1
Operation	5-1
Converting Alternating Current to Direct Current	5-2
Components	
Battery	5-2
Wiring	5-2
Condition	5-2
Wire Gauge	5-2
Electrical Terms	5-3
Basic Checks	5-3
Charging Circuit	5-4
3 Amp D.C. 5 Amp A.C. Alternator	5-4
Diode Replacement	5-4
Checking the System	5-5
16 Amp Alternator System with External Regulator	5-5
Troubleshooting Electrical Charging Circuit Flow Chart	5-6
Voltage Regulators	5-7
Fuel Shut-Down Solenoids	5-7
Low Oil Pressure Sensor Testing	5-7
Starting Circuit	5-8
Testing Procedure Starting Circuit	5-8
Troubleshooting Electrical Starter Circuit Flow Chart	5-9
Electric Starter Service	5-10
12 Volt Electric Starter	5-10
Inspection and Repair	5-11
Brush Holder	5-12
Brush Replacement	5-12
 IGNITION	
General Information	6-1
Operation	
Solid State Ignition System (CDI)	6-1
Components	6-1
Testing Procedure	6-2
Service	
Spark Plug Service	6-3
Conditions Causing Frequent Spark Plug Fouling	6-3
Ignition Timing	6-3
Service Tips	6-4

TABLE OF CONTENTS (continued)

	Page
INTERNAL ENGINE AND DISASSEMBLY	
General Information	7-1
Lubrication Systems	7-1
Disassembly Procedure	7-1
Disassembly of Cylinder Heads	7-4
Valves	7-5
Valve Guides	7-5
Valve Springs	7-6
Push Rods	7-6
Valve Seats	7-6
Internal Engine Component Inspection	
Cylinders	7-7
Pistons	7-8
Rings	7-9
Connecting Rods	7-10
Crankshafts and Camshafts	7-11
Mechanical Compression Release	7-12
Valve Lifters	7-13
Crankcase Breather	7-13
Cylinder Cover	7-13
ENGINE ASSEMBLY	
Engine Assembly	8-1
TROUBLESHOOTING AND TESTING	
Engine Knocks	9-1
Engine Overheats	9-1
Surges or Runs Unevenly	9-1
Engine Misfires	9-1
Engine Vibrates Excessively	9-2
Breather Passing Oil	9-2
Excessive Oil Consumption	9-2
Lack Power	9-2
ENGINE SPECIFICATIONS	
TVT691 Engine Specifications	10-1
Torque Specifications	10-3
Service Tool List	10-4

CHAPTER 1. GENERAL INFORMATION

ENGINE IDENTIFICATION

Tecumseh engine model, specification, and date of manufacture (D.O.M.) are located on decals attached to the blower housing of the engine. The engine identification decal also provides the applicable warranty code, oil and fuel recommendations, EPA (Environmental Protection Agency) and C.A.R.B. (California Air Resource Board) Emission Compliance Information. (Illust. 1-1)



1-1

INTERPRETATION OF ENGINE IDENTIFICATION

The letter designations (TVT) in a **model number** indicate the basic type of engine.

The number designations following the letters (691) indicate the basic engine model displacement in CC's (cubic centimeters). (Illust. 1-2)



1-2

The group of numbers following the model number is the **specification number**. The last three numbers indicate a variation to the basic engine specification. (Illust. 1-3)



1-3

The letter in parenthesis on the engine information decal is the **warranty code identification number**. This letter designates the length of time the engine is under warranty. A cross-reference may be found in the service warranty policy of the master repair manual or the engine operator's manual. (Illust. 1-4)



1-4

The D.O.M. (date of manufacture) indicates the production date of the engine by year and numerical day. (Illust. 1-5)



1-5

Using model **TVT691-600401A D.O.M. 9146** as an example, the interpretation is as follows:

- TVT691-** Is the model number.
- 60041A** Represents the specification number used for properly identifying the parts of the engine.
- TVT** Tecumseh Vertical Twin.
- 691** Indicates the displacement in cubic centimeters.
- 9146** Is the D.O.M. (Date of Manufacture) formerly serial number.
- 9** Is the last digit in the year of manufacture (1999).
- 146** Indicates the calendar day of that year (146th day or May 26th of 1999).
- A,B,C** A letter following the D.O.M. number represents the line, shift and plant in which the engine was built.

Emissionized engines that meet the California Air Resource Board (C.A.R.B.) or the Environmental Protection Agency (EPA) standards will include additional required engine information on the engine decal.

NOTE: To maintain the best possible emission performance, use only Genuine Tecumseh Parts.

 This symbol points out important safety INSTRUCTIONS, WHICH IF NOT FOLLOWED, could endanger the personal safety of YOU and others. Follow all instructions.

SHORT BLOCKS

New short blocks are identified by a tag marked S.B.V. (Short Block Vertical) located on the engine block. When a short block repair is made, it is vital both the original engine and short block numbers are present on the repaired product for correct future parts identification. (Illust. 1-6)

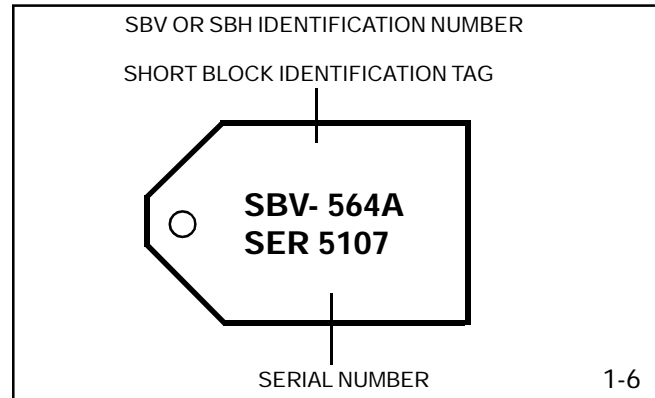

1-6

FUELS

Tecumseh Products Company strongly recommends the use of fresh, clean, unleaded regular gasoline in all Tecumseh engines. Unleaded gasoline burns cleaner, extends engine life, and promotes good starting by reducing the build up of combustion chamber deposits. Unleaded regular, unleaded premium or reformulated gasoline containing no more than 10% Ethanol, 15% MTBE or 15% ETBE may be used.

Leaded fuel is not available in the United States and should not be used if any of the above options are available.

Never use gasoline, fuel conditioners, additives or stabilizers containing methanol, white gas, or fuel blends, which exceed the limits, specified above for Ethanol, MTBE, or ETBE because engine/fuel system damage could result.

 **CAUTION: THE USE OF SOME ANTI-ICING ADDITIVES MAY CREATE A METHANOL FUEL BLEND. DO NOT USE ADDITIVES THAT CONTAIN METHANOL. FUEL CONDITIONERS THAT CONTAIN ISOPROPYL ALCOHOL CAN BE USED IN CORRECT MIXTURE RATIOS.**

Regardless of which of the approved fuels are used, fuel quality is critical to engine performance. Fuel should not be stored in an engine or container more than **30 days** prior to use. Time may be extended with the use of a **fuel stabilizer** like **TECUMSEH, part number 730245**. See "STORAGE" instructions in this Manual, Operators Manual, or Bulletin 111.

ENGINE OIL

TECUMSEH FOUR-CYCLE ENGINES REQUIRE THE USE OF CLEAN, HIGH QUALITY DETERGENT OIL.

Be sure original container is marked: A.P.I. service "SF" thru "SJ" or "CD".

TECUMSEH RECOMMENDS USING ONE OF THE FOLLOWING FOUR CYCLE OILS THAT ARE SPECIALLY FORMULATED TO TECUMSEH SPECIFICATIONS.

DO NOT USE SAE 10W40 OIL.

FOR SUMMER (Above 32° F) (0°C) USE SAE 30 OIL. PART 730225

Use SAE 30 oil in high temperature, high load applications. Using multigrade oil may increase oil consumption.

FOR WINTER (Below 32°F) (0°C) USE SAE 5W30 OIL. PART 730226

(SAE 10W is an acceptable substitute.)

(BELOW 0°F (-18°C) ONLY): SAE 0W30 is an acceptable substitute.

Oil Capacity		
Engine Model	oz.	ml.
TVT691 with Filter	80	2366
TVT691 Oil Only	72	2129

Change oil and filter after the first two operating hours. Standard oil change intervals are every 50 hours. Oil filter changes are recommended every 100 operating hours.

Oil Change Intervals: Change the oil and filter after the first 2 hours of operation. Thereafter oil change intervals are every 50 hours. Oil and oil filter changes are requested every 100 operating hours. Service should be performed more often if operated under extremely dusty or dirty conditions. The oil and filter (if equipped) should be changed yearly if operated less than 100 hours.

Oil Check: Check the oil each time the equipment is used or every five-(5) hours of operation. Position the equipment so the engine is level when checking the oil level.



CAUTION: A TWIN CYLINDER ENGINE MAY START AND RUN ON ONLY ONE CYLINDER. ALWAYS DISCONNECT **BOTH** SPARK PLUG WIRES FROM THE SPARK PLUGS AND GROUND TO THE DEDICATED RETAINING POSTS LOCATED ON THE VALVE COVER BOXES BEFORE ATTEMPTING ANY SERVICE OR MAINTENANCE WORK ON THE ENGINE OR EQUIPMENT.

Oil Change Procedure: Locate the oil drain plug in the mounting flange. The drain plug or cap on most units is located above the frame in one of the locations shown. (Illust. 1-7) The oil filter if equipped, can be removed with a commercially available filter wrench.

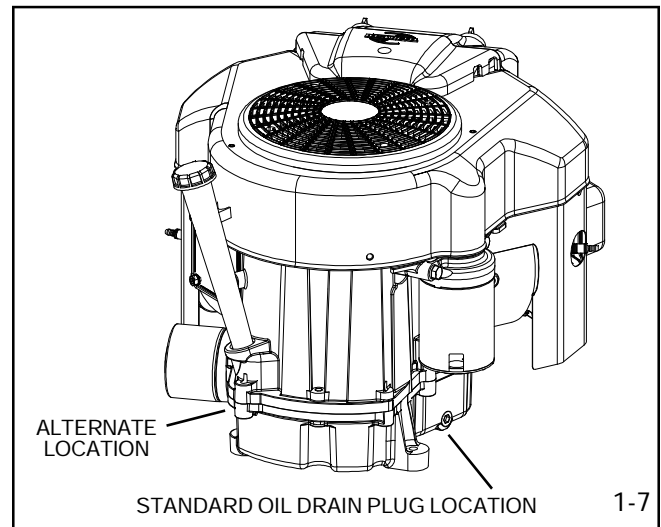

NOTE: An oil change is best performed after the engine is warm.

Remove the oil plug or cap and allow the oil to drain into a proper receptacle. Always make sure that drain oil and filter are disposed of properly. Contact your local governing authorities to find a waste oil disposal site. Once the oil is drained, reinstall the drain plug and fill the engine with new oil to the proper capacity.

BASIC MAINTENANCE CHART	
Pre-filter (Dry Poly)	Clean every 25 hours
Air filter (Paper Element)	Replace every 100 hours of operation
Oil change	Every 50 hours or annually
Oil filter	Every 100 hours or annually
Spark plug replacement	Every 100 hours or annually
Clean cooling fins	Every 200 hours or annually
Fuel Filter (Replace)	Every 100 hours or annually

BASIC TUNE-UP PROCEDURE:

NOTE: Today's fuels can cause many problems in an engine's performance due to the fuel quality and short shelf life (as little as 30 days). Always check fuel as a primary cause of poor engine performance before performing any other service.

The following is a minor tune-up procedure. When this procedure is completed, the engine should operate properly. Further repairs may be necessary if the engine's performance remains poor.

CAUTION: REMOVE THE SPARK PLUG WIRES AND ATTACH TO THE DEDICATED RETAINING POSTS BEFORE DOING ANY SERVICE WORK ON THE ENGINE.

1. Service or replace the air cleaner. See **Chapter 2** under "Service".
2. Inspect the level and condition of the oil, change or add oil as required.
3. Remove the blower housing and clean all dirt, grass or debris from the intake screen, Cylinder head, cooling fins, carburetor, governor levers and linkage.
4. Check that the fuel filter, fuel tank, and fuel line are clean. We recommend replacing the fuel filter every 100 hours or annually.
5. Replace the spark plugs every 100 hours or annually, consult the parts breakdown for the correct spark plug to be used. Set the spark plug gap **(.030") (.762 mm)** and install the plug, being careful not to cross thread. Tighten the spark plug to **21 foot pounds (28 Nm) of torque**. If a torque wrench is not available, turn the spark plug in as far as possible by hand, then use a spark plug wrench to turn the plug 1/2 turn further. If installing a used plug, only 1/8 to 1/4 turn after seat is needed. Note: The correct plug reach must be used see (Illust. 1-8).

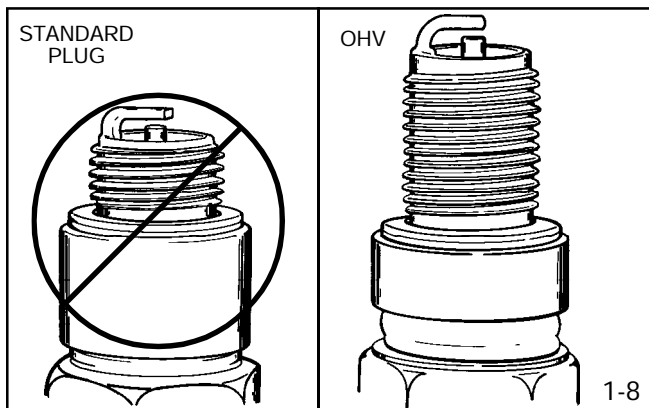

6. Make sure all ignition wires are free of abrasions or breaks and are properly routed so they will not rub on the flywheel.
7. Completely clean the cooling fins, intake screen and linkages of all dirt and debris. Reinstall the blower housing, fuel tank, fuel line, and air cleaner assembly if removed. **Be careful not to pinch any of the wires upon re-assembly.**
8. Make sure all remote cables are correctly routed and adjusted for proper operation. See **Chapter 4**, under "Speed Controls and Linkage".
9. Reinstall the spark plug wires, add fuel and oil as necessary, start the engine.

STORAGE

(IF THE ENGINE IS TO BE UNUSED FOR 30 DAYS OR MORE)

CAUTION: NEVER STORE THE ENGINE WITH FUEL IN THE TANK INDOORS OR IN ENCLOSED, POORLY VENTILATED AREAS, WHERE FUEL FUMES MAY REACH AN OPEN FLAME, SPARK OR PILOT LIGHT AS ON A FURNACE, WATER HEATER, CLOTHES DRYER OR OTHER GAS APPLIANCE.

Gasoline can become stale in less than 30 days and form deposits that can impede proper fuel flow and engine operation. To prevent deposits from forming, all gasoline must be removed from the fuel tank and the carburetor. An acceptable alternative to removing all gasoline, is by adding **Tecumseh fuel stabilizer, part number 730245**, to the gasoline. Fuel stabilizer is added to the fuel tank or storage container. Always follow the mix ratio found on the stabilizer container. **Run the engine at least 10 minutes after adding the fuel stabilizer to allow it to reach the carburetor. (Illust. 1-9)**



CHAPTER 2. AIR CLEANERS

GENERAL INFORMATION

The air cleaner is the device used to eliminate dust and dirt from the air supply. Filtered air is necessary to assure that abrasive particles are removed before entering the combustion chamber. Dirt allowed into the engine will quickly wear the internal components and shorten engine life.

The TVT series engine uses a paper-type air filter system and also has a dry foam pre-filter.

Extremely dirty conditions require more frequent pre-filter cleaning or paper element replacement.

OPERATION

The air filter cover secures and seals the paper filter element in place. The cover also prevents large particles from entering the filter body and completes the Kleen-Aire® circuit. The air is first filtered through the flywheel and blower housing then enters the air filter cover. It travels through the pre-filter then the paper filter element. Pre-filters typically extend the paper filter life. (Illust. 2-1)

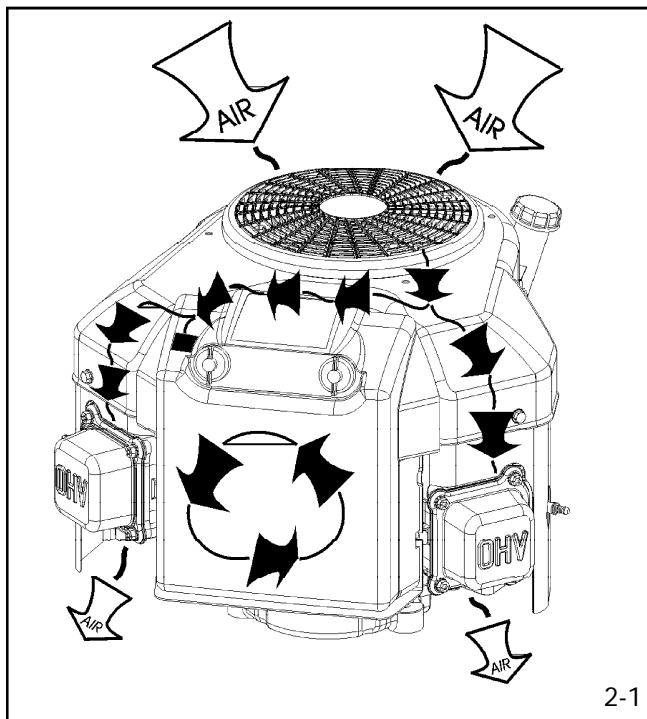

COMPONENTS

The **cover** holds the poly pre-cleaner and clamps the paper filter in place, creating a dirt tight seal. The cover also prevents large debris from entering the filter body.

The **pre-cleaner** is made of a polyurethane foam and designed to pre-filter the air prior to it passing through the paper filter. This added stage, assures the operator of maximum air filtering and extends paper filter life.

The **paper filter element** is the main filter to stop impurities from entering the engine. This dry-type element is pleated paper for increased surface area maximizing its life. The filter has rubberized edges to assure sealing. (Illust. 2-2)



2-2

TROUBLESHOOTING AND TESTING

If the engine's performance is unsatisfactory (runs unevenly, starts smoking abnormally or loses power), the first engine component(s) to be checked are the air filter(s). A dirt restricted or oil soaked filter will cause noticeable performance problems. Polyurethane pre-filter can be cleaned following the service procedure listed under "Service" in this chapter. A paper-type air filter can only be replaced **NEVER attempt to clean a paper filter**. The paper-type filter must not have any oil film or residue present. Should the paper have a brown tint it may have been damaged by an excessively oiled pre-filter or crankcase breather problems. Follow the procedure listed in the "Service" section of this chapter for filter replacement or cleaning.

SERVICE

Cleaning of the polyurethane pre-filter element is recommended every twenty-five (25) operating hours or (3) months, whichever comes first. Extremely dirty or dusty conditions may require daily cleanings.

NOTE: Do not oil the pre-filter, paper element damage can occur.

The paper filter element should be replaced once a year or every 100 operating hours, more often if used in extremely dusty conditions.

NOTE: Never run the engine without the complete air cleaner assembly installed on the engine. Always replace the filter element with a Tecumseh original replacement part to maintain proper filtration, emissions compliance and long engine life.

Disassembly Procedure

1. Remove the wing nuts holding the air cleaner cover in place. Swing the cover out, then lift to remove. (Illust. 2-3)

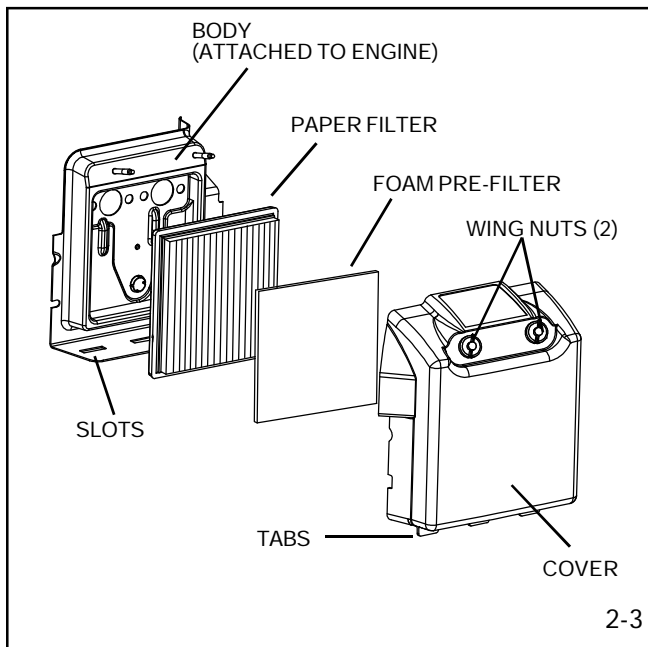

2. Remove the paper filter. **Note:** Paper filters must be replaced **NEVER attempt to clean a paper filter.**
3. Remove the polyurethane pre-cleaner from the cover.
4. Wipe or wash out the air filter cover and base. (Illust. 2-4)



2-4

5. Service the polyurethane pre-filter element by washing in liquid dish soap and warm water until clean. Squeeze out the excess water (**Never Twist**). Finish drying the element by squeezing it in a dry cloth or paper towel.

NOTE: DO NOT OIL THE PRE-FILTER IT MUST BE INSTALLED DRY TO PREVENT SATURATION OF THE PAPER FILTER ELEMENT.

6. Install the pre-cleaner and new air filter in the cover. Replace the filter cover and tighten the wing nuts, be careful not to over-tighten it. **Note:** The air filter system on all models can be upgraded to include the pre-cleaner if the OEM did not originally request one.

CHAPTER 3. CARBURETORS AND FUEL SYSTEMS

GENERAL INFORMATION

The TVT engine uses two series seven (7) float type carburetors. This carburetor uses a choke enrichment system to provide easy cold engine starting. To comply with emission standards, the carburetor idle and high-speed fuel mixtures are non-adjustable. Carburetor cleaning and related fuel system service is covered in this chapter.

FLOAT STYLE CARBURETORS

A float is used to maintain the operating level of fuel in the carburetor bowl. As the engine consumes fuel, the fuel level in the carburetor bowl drops and the float moves downward. This allows the inlet needle valve to move off the sealing seat, and fuel to enter the carburetor float bowl. As the fuel level in the bowl rises, it elevates the float. This upward float motion moves the inlet needle valve to the closed position. When the needle contacts the seat, the fuel flow is stopped. The tapered end of the inlet needle varies the fuel flow rate keeping the supply constant. (Illust. 3-1) The float height on the series 7 carburetor is fixed and may not be adjusted.

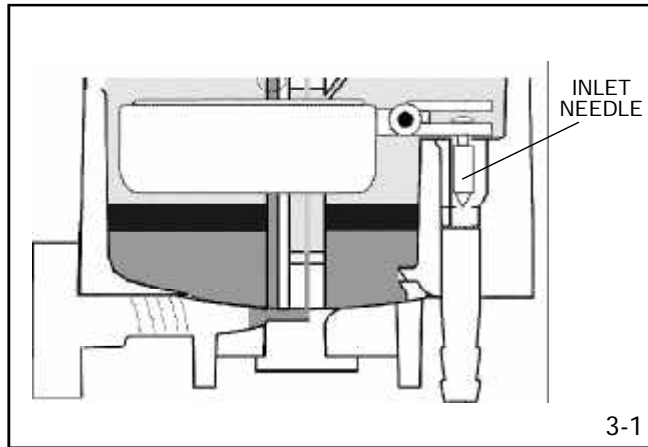

NOTE: Gravity fed systems must have the bottom of the fuel tank no lower than the fuel inlet of the carburetor.

When servicing carburetors, use the engine model and specification number to obtain the correct carburetor part number or parts. An alternate method is to use the manufacturing number stamped on the carburetor. Convert this number to a service part number in Div. 5 carburetor section of the Master Parts Manual. This method can also be used in microfiche and computer parts look-up systems.

OPERATIONAL CIRCUITS SERIES 7 CARBURETOR

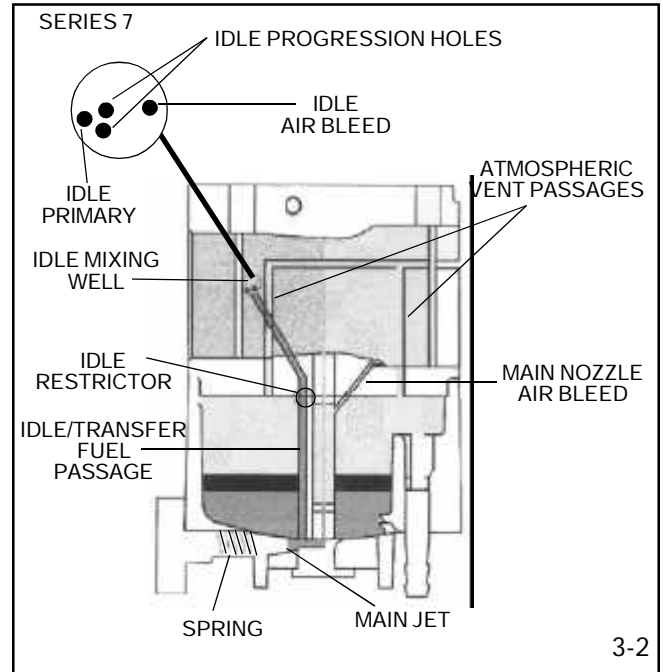

Choke Circuit: In the "CHOKE"/"START" position, the choke shutter is closed, and the only air entering the engine, enters through openings around the shutter. As the starting device cranks the engine over, the pistons travel downward on the intake stroke, creating a low-pressure area in the cylinder. High-pressure (atmospheric) air rushes into the cylinder to fill the low-pressure area created.

Since the choke shutter blocks the majority of the air passage, a relatively small quantity of air enters the carburetor. The main nozzle and idle fuel discharge ports are all supplying fuel at this point. This is due to the increased low air pressure in the intake system of the engine. A maximum fuel flow through the carburetor orifices combined with the reduced quantity of air that passes through the carburetor, creates a very rich fuel mixture needed to start a cold engine.

Governed Idle Circuit: The TVT series engine uses a governed idle system. In the low speed throttle position, engine speed is being maintained by the governor NOT the idle speed adjustment screw. The governed idle system improves throttle response when the engine load changes. The relatively small amount of fuel/air mixture is supplied through the primary idle orifice location under the idle mixing well welch plug. (Illust. 3-3)

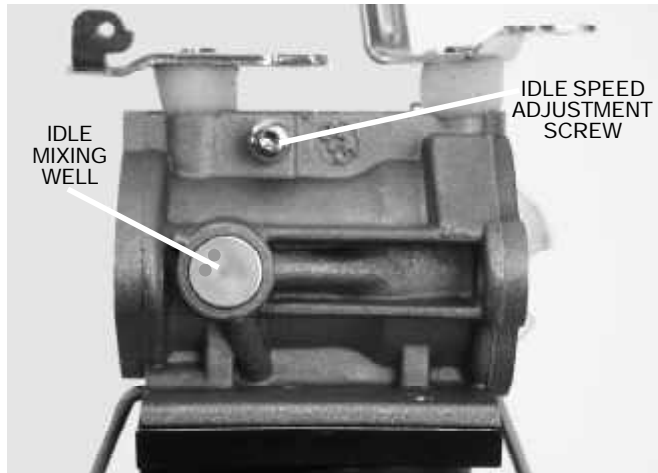

3-3

True Idle: The idle speed adjustment screw on governed idle engines perform as a stop to prevent complete closure of the throttle plate. This partial open throttle position is required for good starting performance. The idle adjustment screw is set 600 RPM lower than the governed idle speed. (Found on microfiche card #30 or the computer parts look-up systems.) See governed speed adjustment procedure **Chapter 4**.

CAUTION: DUAL CARBURETORS MUST BE PROPERLY SYCRONIZED. DO NOT ADJUST IDLE SPEED SCREW WITHOUT PROPER SYNCHRONIZATION.

Transfer/Intermediate Circuit: During Intermediate engine operation or light loads, additional orifices are uncovered in the idle mixing well, as the throttle shutter opens. The fuel being released from these jets is already pre-mixed (atomized) with air prior to entering the air stream in the venturi of the carburetor. When the fuel enters the air stream it further mixes with the air which maximizes combustibility.

Idle Mixing Well: The idle mixing well of the carburetor contains a series of metering holes. These metering holes are the primary and secondary idle circuit as well as the idle air bleed hole. Proper servicing of the carburetor requires removal of the welch plug and cleaning of these metering holes. (Illust. 3-4)

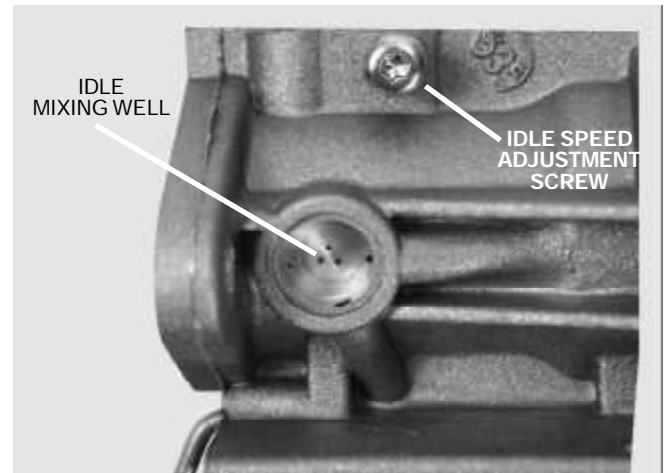

3-4

High Speed Circuit: During HIGH-SPEED engine operation, the throttle shutter is opened beyond the idle/transfer discharge ports. Air is flowing through the carburetor(s) at a high rate. The venturi, which decreases the size of the air passage through the carburetor, causes the airflow to further accelerate. This rapidly moving air creates a low-pressure area at the main nozzle (Emulsion Tube) discharge opening.

Using air that is channeled to the emulsion tube through the main nozzle air bleed, a mixture of fuel and air is drawn up the emulsion tube.

The addition of air creates an atomized mixture before being discharged into the venturi. Fuel flow is created by the difference in the atmospheric air pressure on the fuel in the carburetor bowl and the main nozzle opening.

Atmospheric Vent: For the fuel to flow out of the carburetor, the bowl must be vented to atmospheric pressure. The internal vent is located at the 4 o'clock position from the choke end of the carburetor. (Illust. 3-5) This passage should be checked for blockage if engine performance is in question.

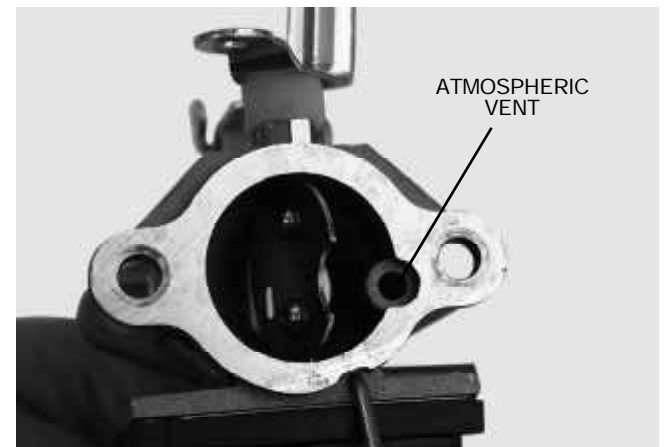

3-5

Main Nozzle Air Bleed: Air is bled into the main nozzle through the main nozzle air bleed passage located in the 6 o'clock position of the carburetor's choke end. (Illust. 3-6) This passage allows air to mix with the fuel traveling up the main nozzle creating a pre-atomized mixture. The fuel is then released into the venturi from the nozzle tip. Atomization occurs as the fuel mixture contacts the fast moving air stream in the venturi and flows into the intake of the engine.

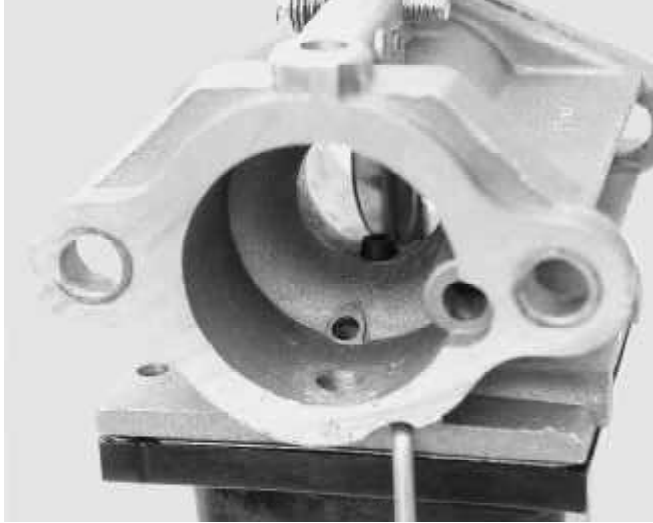

3-6

Low Speed Idle Air Bleed: The low speed circuit of the carburetor has an idle air bleed passage which performs the same function as the high-speed air bleed. It pre-mixes fuel and air prior to entering the throat of the carburetor. This passage is located in the idle mixing well (Illust. 3-7)

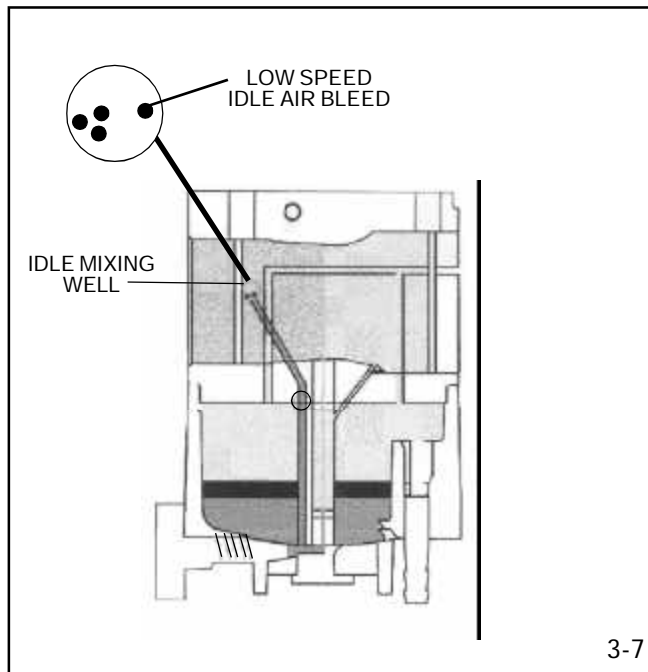

3-7

TESTING

1. Should repeated efforts to start the engine using the procedure listed in the operator's manual fail, check for spark by removing the high-tension lead. Install an ignition tester and check for spark. If the spark is bright blue and consistent, proceed to step 2. If no or irregular spark see **Chapter 6 under "Testing"**.

⚠ CAUTION: KEEP ALL COMBUSTIVE SOURCES AWAY. AVOID THE SPRAY FROM THE SPARK PLUG HOLE WHEN CRANKING THE ENGINE OVER AND MAKE SURE THE PLUG WIRES ARE PROPERLY GROUNDED TO THE DEDICATED RETAINING POSTS.

2. Remove and visually inspect the condition of each spark plug, a wet condition indicates the presence of gasoline in the cylinder. Although this indicates fuel is present the fuel condition regarding its combustibility should always be checked.

NOTE: Check plug for correct reach. (Illust. 3-8)

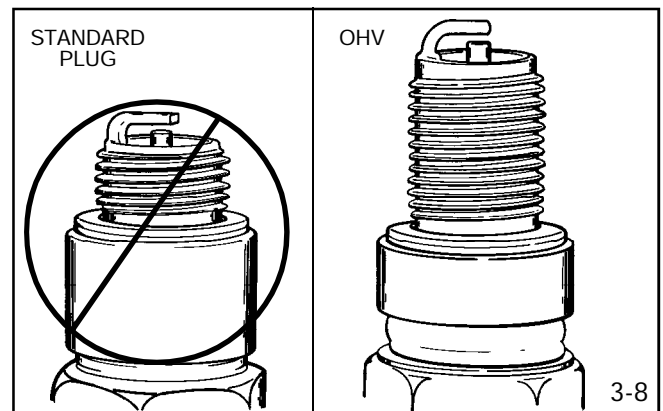

3-8

3. If either spark plug is dry, check for restrictions in the fuel system, which supplies that cylinder. If both plugs are dry check the fuel supply system and continue with step #4. If the spark plug is wet, continue with step # 8.

4. **Dry Spark Plug:** Begin by checking the fuel cap for proper atmospheric venting. With the fuel cap in place and tightened, remove the fuel line prior to the pump allowing fuel to flow into a proper receptacle. Allow at least 1 gallon of fuel to flow out, noting the rate of flow. If it remains consistent the vent is performing properly. Re-connect the fuel line(s) to the pump.

NOTE: Today's fuels can cause many problems in engine performance due to the fuels quality and short shelf life. Always check fuel as a primary cause of engine poor performance.

5. Remove the air filter, visually check the choke shutter(s) operation for complete closure when the throttle or independent choke control are in the full choke position.

6. **Fuel Supply** If the fuel flow to the carburetors is adequate and no fuel is evident at either spark plug, the carburetor bowl(s) will need to be removed for service. See "Service" in this chapter or consult the "Carburetor Troubleshooting" chart to diagnose carburetor symptoms. Improper fuel flow indicates the fuel, fuel line, filter or tank require cleaning or replacement.

7. **Compression Test** Most Tecumseh engines include a compression relief system. These systems make publishing compression values impractical. However, following is a **cylinder compression balance test**, which can be preformed to help diagnose a possible compression concern.

1. Remove air filter cover, air filter and both spark plugs
2. Ground out the spark plug wires to the engine.
3. Install a compression tester into either of the spark plug holes of the cylinder head.
4. Turn engine over until the highest reading is recorded on the compression tester.
5. Write down the reading, remove the compression tester install it into the remaining cylinder head and repeat.

Compare the two readings. The difference between the two cylinders should not exceed 20%. Example: Cyl #1 90 PSI, Cyl #2 75 PSI. There is 15-PSI difference between cylinders. Divide this number (15) into the highest compression reading (90) giving a 17% difference between cylinders. A difference above 20% or an extremely low compression reading (below 50 PSI) will require further leak testing or cylinder head removal for inspection.

Cylinder #1	Cylinder #2	Difference	%
90 psi	- 75 psi	= 15 psi	÷ 90 = 17%

8. **Wet Plug(s)** A wet spark plug indicates fuel is being supplied by the carburetor. A restricted air filter, carbon shorted or defective spark plug, excessive choking or a defective carburetor, may have flooded the engine. With the spark plug(s) removed and the plug wire(s) grounded to the dedicated retaining posts, place a shop towel over the spark plug hole. Turn the engine over very slowly by hand to remove excess gasoline from the engine cylinder.



CAUTION: KEEP ALL COMBUSTIVE SOURCES AWAY. AVOID THE SPRAY FROM THE SPARK PLUG HOLE WHEN CRANKING THE ENGINE OVER AND MAKE SURE THE PLUG WIRES ARE PROPERLY GROUNDED TO THE DEDICATED RETAINING POST.

9. Replace the air filter if restricted or oil soaked, if the paper filter has a brown color it may have been damaged by oil and should be replaced. Replace the spark plug if questionable then install the spark plugs and high tension leads. Attempt to start the engine.
10. If the engine floods and fails to start, the carburetor(s) will require service. See the "Carburetor Troubleshooting" chart for additional causes. If the carburetor is functioning properly the problem may be ignition or timing related. Reference "Troubleshooting" under "Ignition" for further assistance.

CARBURETOR DISASSEMBLY PROCEDURE

Before performing any carburetor service check the throttle/choke control(s) for proper adjustments. Make sure the unit is reaching full choke shutter position on both carburetors.

NOTE : The series seven carburetor uses FIXED IDLE AND MAIN JETS AND SHOULD BE SERVICED ONLY BY QUALIFIED TECHNICIANS TO PREVENT DAMAGE. It is a violation of both the U.S. EPA and CARB regulations to modify the carburetor from the original factory jetting unless specifically authorized.

⚠ CAUTION: DRAIN THE FUEL INTO AN APPROVED CONTAINER OUTDOORS, AND AWAY FROM ANY OPEN FLAME OR COMBUSTION SOURCE. BE SURE THE ENGINE IS COOL.

1. Remove the fuel line. Use care not to damage the float bowl or retainer. Disconnect the wires from the fuel shut-off solenoids. Release the float bowl retainer bail. The float bowl assembly may now be removed by pulling straight down. (Illust. 3-9)



3-9

2. Remove the main nozzle (Emulsion) tube, "O" ring, and spring located in the center leg of the float bowl. (Illust. 3-10)

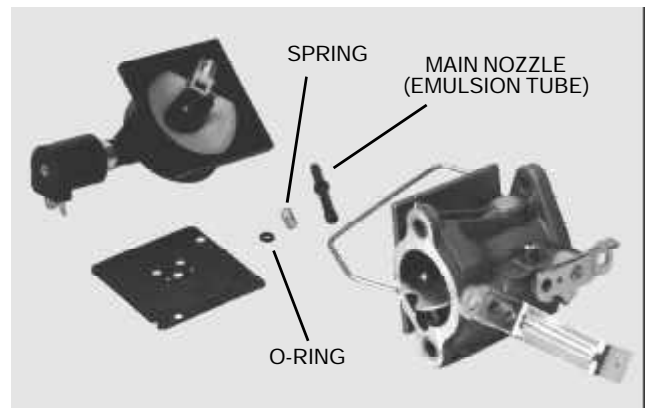

3-10

3. Next remove the bowl drain screw or fuel shut off solenoid and gasket. Remove the spring, metering jet, and "O" ring. (Illust. 3-11)

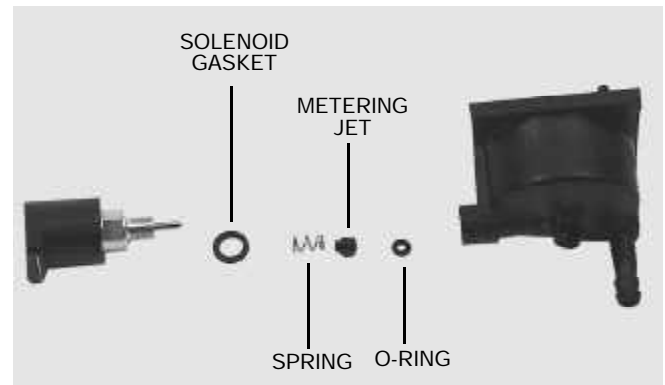

3-11

4. Float removal is done by grasping the cross-brace on the float with needle nose pliers. Then pulling in a horizontal motion to release the float assembly. (Illust. 3-12) Removal by any other method may cause damage.

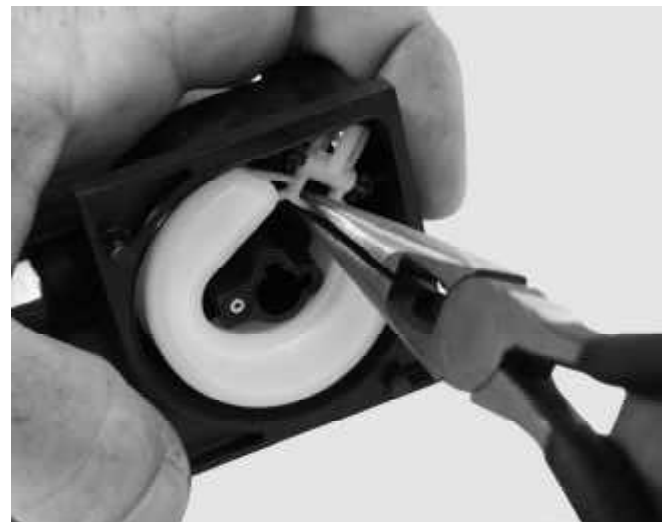

3-12

- Remove the inlet needle seat using a No. 4 crochet hook or a paper clip with a **3/32" (2.38 mm)** hook end. Push the hook through the hole in the center of the seat and pull out to remove it. **NOTE:** A metal retaining ring may be present on top of the seat to aid in its retention, this will come out with the seat. If a ring is present or comes with the new seat reinstall it. (Illust. 3-13)

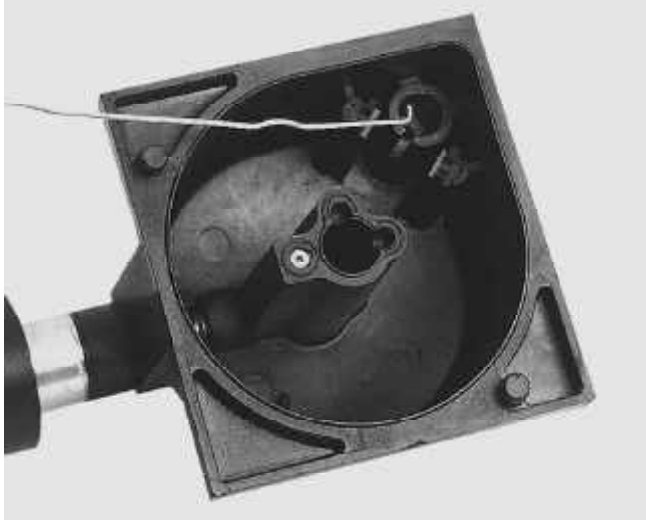

3-13

- Idle Restrictor:** The idle restrictor is located to the side of the center leg in the fuel bowl. (Illust. 3-14) Clean the passage using a piece of wire (maximum **.015, .0006 mm**), carburetor spray and compressed air, verify it is open. If the restrictor remains plugged it can be serviced by replacement of the float bowl assembly only.

NOTE: New service fuel bowls come with the restrictor installed.

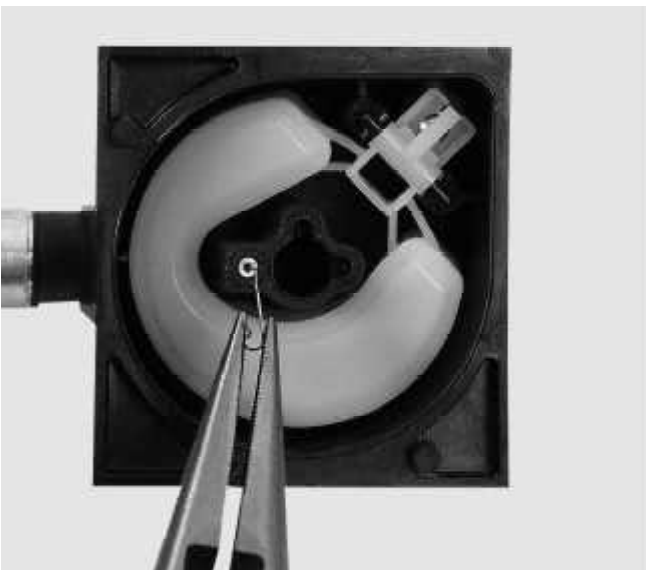

3-14

NOTE: Before removing the main carburetor body, mark or sketch the choke and throttle linkage connection points. Also **MARK THE EDGES OF THE THROTTLE AND CHOKE SHUTTERS. THE SHUTTERS HAVE BEVELED EDGES AND MUST BE INSTALLED IN THE ORIGINAL POSITION.**

- Use a Torx T-10 to remove the choke and throttle shutters. Remove the throttle shaft, choke shaft and return springs.
- Welch plug Removal:** Secure the carburetor in a vise equipped with protective jaws. Use a small chisel sharpened to a **1/8" (3.175 mm)** wide wedge point. Drive the chisel into the plug to pierce the metal and push down on the chisel prying the plug out of the hole. (Illust. 3-15)

NOTE: Be careful not to drive the chisel through the plug damaging the metering holes underneath.

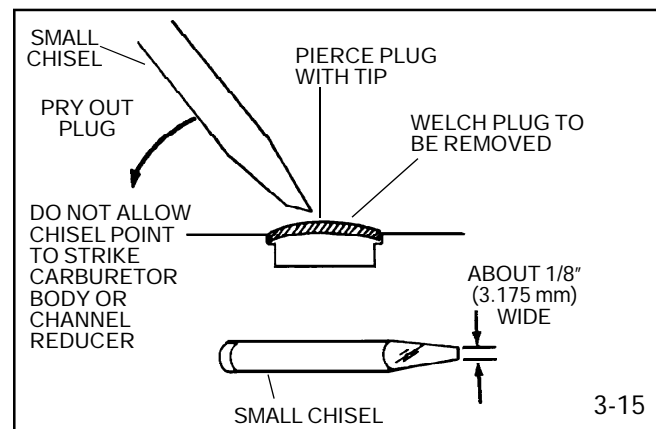

3-15

INSPECTION

After careful disassembly of the carburetor, clean the carburetor body and float bowl with solvent, or spray carburetor cleaner. Wearing eye protection, use compressed air and soft tag wire to clean internal carburetor passages. (Illust. 3-16) Examine the float for cracks or leaks. Check the float hinge bearing surfaces for wear, as well as the tab that contacts the inlet needle. Examine the throttle, choke shaft, and carburetor body at the bearing points and holes into which the linkage is fastened. If dust seals are present, check the seal condition and for correct placement next to the carburetor body. If the condition of any of these parts is worn or questionable replace them. The float can be checked for leakage by submersion in a clear jar filled with hot water. If any air bubbles are noted the float must be replaced.

NOTE: DO NOT INTERCHANGE MAIN NOZZLES OR METERING JETS FROM OTHER CARBURETORS.

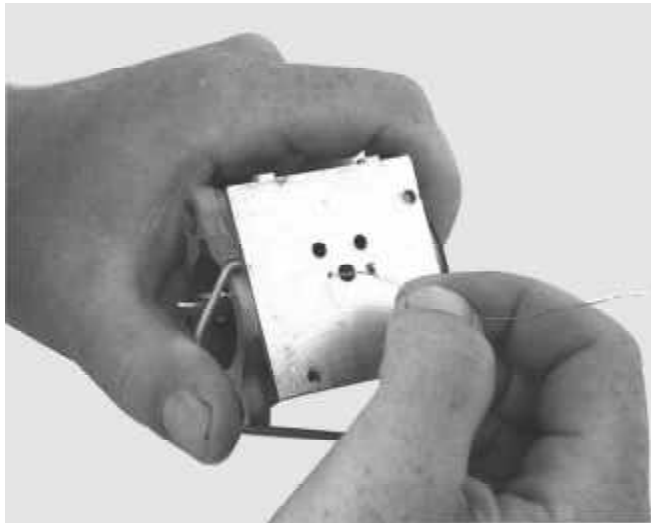

3-16

CARBURETOR RE-ASSEMBLY WELCH PLUGS

To install a new welch plug, secure the carburetor in a vise equipped with protective jaws. Place the welch plug into the mixing well pocket with the raised portion up. With a punch equal to the size of the plug-hole, flatten the plug. Do not dent or drive the center of the plug below the top surface of the carburetor. After installation of the welch plug, seal the outer diameter with fingernail polish. (Illust. 3-17)

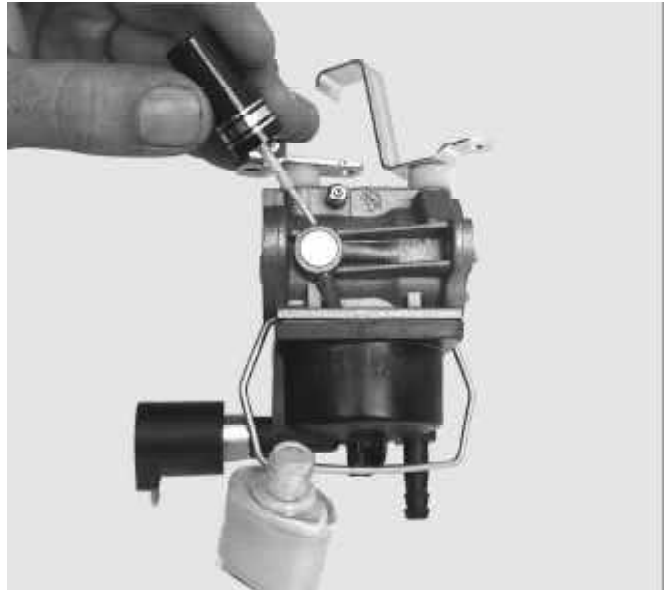

3-17

THROTTLE SHAFT AND PLATE

When reassembling the throttle plate on a series 7 carburetor, it is important that the marking on the plate be in the 3 o'clock position facing out with the throttle plate closed. (Illust. 3-18)

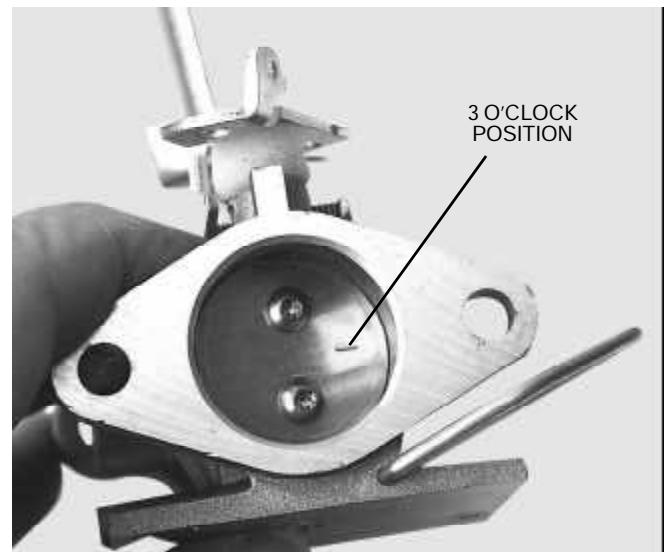

3-18

CHOKE SHAFT AND PLATE

Install the choke return spring on the choke shaft with the squared end up and hooked into the notch on the arm. Work the dust shield up around the spring and insert the choke shaft into the carburetor body. Rotate the shaft counterclockwise until the tang on the spring rests against the left side center boss on the carburetor body. (Illust. 3-19)

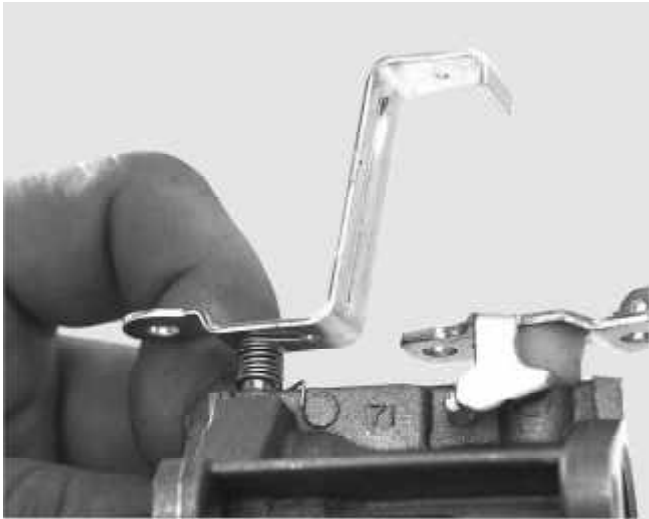

3-19

Always use new shutter screws part 650506 when reinstalling a shutter plate. Install the screws so they are slightly loose. Apply light downward pressure on the shaft and rotate it clockwise to seat the shutter in the bore, then tighten the shutter screws. Check for binding by rotating the shaft. If necessary, adjust the shutter by loosening and repositioning, then retighten the screws.

FUEL BOWL ASSEMBLY

Inlet Needle & Seat

When servicing the fuel bowl assembly, a new needle and seat should always be installed to reduce the possibility of leakage.

Make sure the seat cavity is clean. Moisten the seat with oil and insert the seat with the grooved side down and away from the inlet needle. Press the seat into the cavity using a **5/32" (3.969 mm)** Allen wrench or a flat punch, making sure it is firmly seated. (Illust. 3-20) If the new needle and seat contains a retainer install it on top and in contact with the seat.

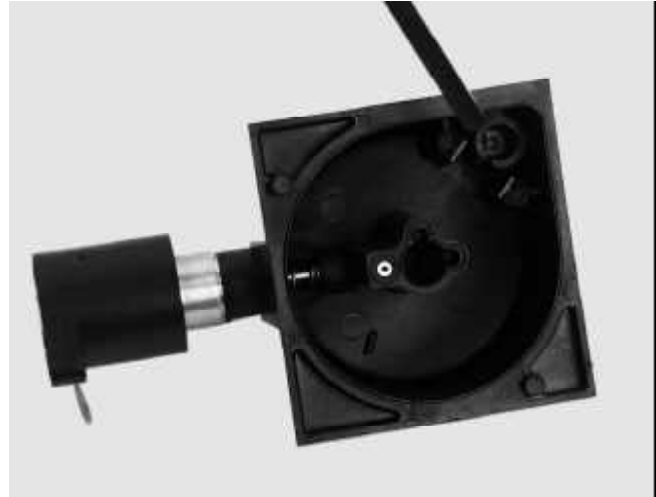

3-20

Main Jet Assembly

Install a new O-ring in the main jet cavity (verify the original o-ring has been removed). Place the spring over the shoulder of the main jet and insert into the cavity with the main jet towards the o-ring. Next install a new fiber gasket on the bowl drain screw or fuel shut-off solenoid and tighten to **25-30 In. lbs. (2.83 - 3.4 Nm)**. (Illust. 3-21)

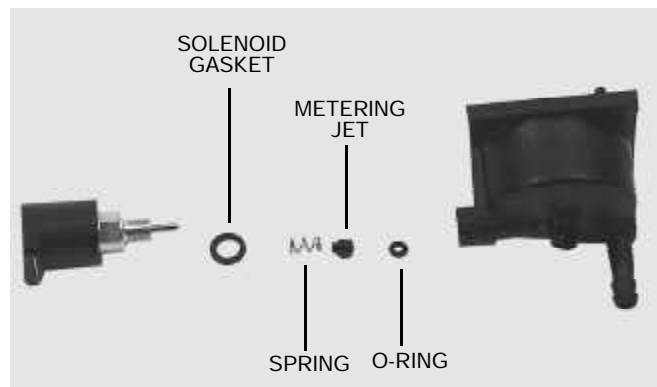

3-21

Main Nozzle (Emulsion Tube)

Place the main nozzle tension spring into the cavity of the float bowl. Apply a small amount of oil to the o-ring on the main nozzle and insert it into the float bowl cavity.

Float Installation

Install the float with a new inlet needle and float hinge pin onto the float bowl assembly. Carefully push the hinge pin into the retaining post using a small flat blade screwdriver. Check the float movement for complete travel.

NOTE: EMISSIONIZED ENGINES OPERATED WITHIN THE UNITED STATES MAY HAVE HIGH ATTITUDE JETS AVAILABLE, CONSULT SERVICE BULLETIN 110 FOR INFORMATION.

Final Checks

Test the inlet needle and seat sealing using Tecumseh service kit 670340 or a similar pop-off tester. To test the pop off pressure remove the float bowl, float and inlet needle. Place a drop of fuel on the seat and reinstall the needle and float. Hook up the pressure tester and apply approximately **6-9 PSI** of pressure or until the needle pops off the seat. Slowly release the pressure to not less than **1 ½ PSI**. The needle should seat between **1 ½ - 6 PSI** for a minimum of five minutes. If the minimum **1 ½ PSI** cannot be maintained the needle and seat will need to be serviced. (Illust. 3-22)

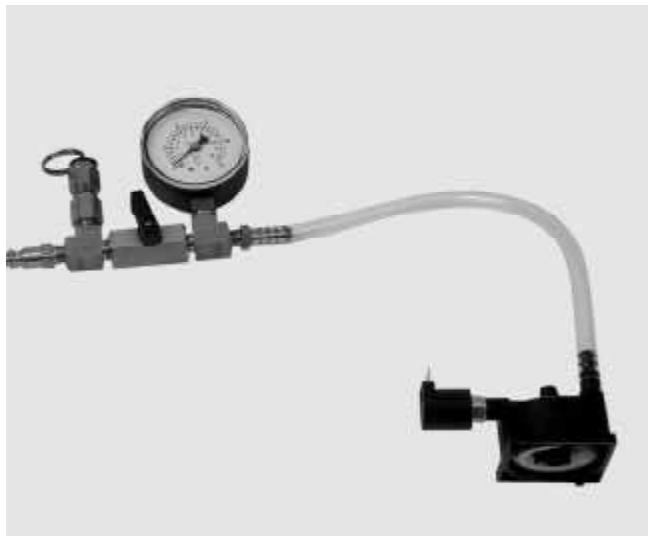

3-22

Fuel Bowl Retaining Bail

The retainer bail must hold adequate pressure on the float bowl to prevent air or fuel leakage during operation. When re-installed, the force should be adequate to securely clamp the bowl to the body of the carburetor. If damage occurred upon bowl removal replace the bail.

IMPULSE FUEL PUMPS

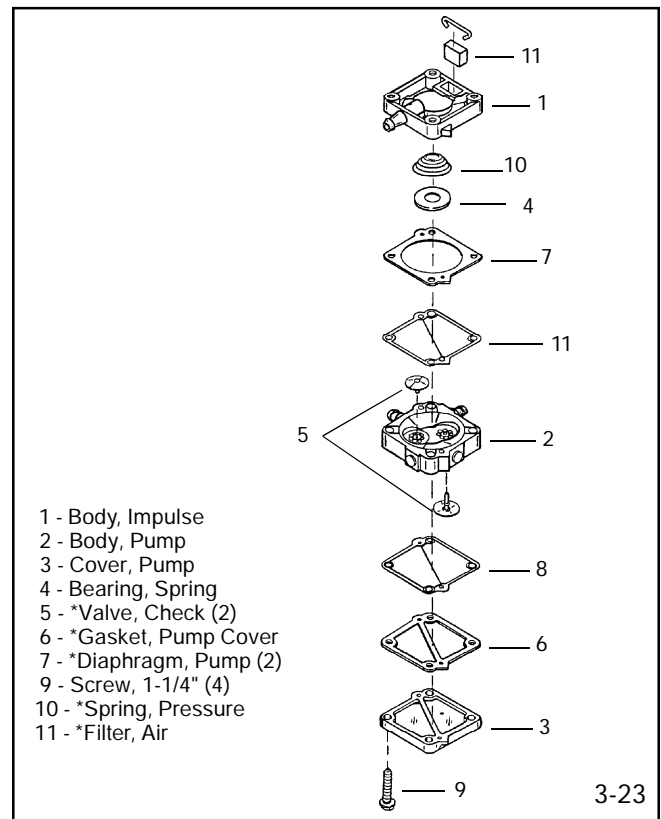

Impulse fuel pumps are externally mounted in the fuel circuit between the fuel supply and the carburetor. A fuel pump must be used if the fuel supply outlet is lower than the bowl inlet. There **MUST** be an in-line fuel filter installed prior to the pump to prevent system damage.

Impulse fuel pumps are operated by positive and negative pressure pulsation in the crankcase, which are created by the up, and down movement of the piston. A hose called a pulse line, connects the fuel pump diaphragm chamber to the crankcase and transmits the pulses to the pump diaphragm. These impulses actuate the diaphragm creating the pumping action to lift the fuel from the fuel tank to the carburetor(s). (Illust. 3-24) The pump body contains check valves, which open and close preventing the fuel from going backwards from the pump.

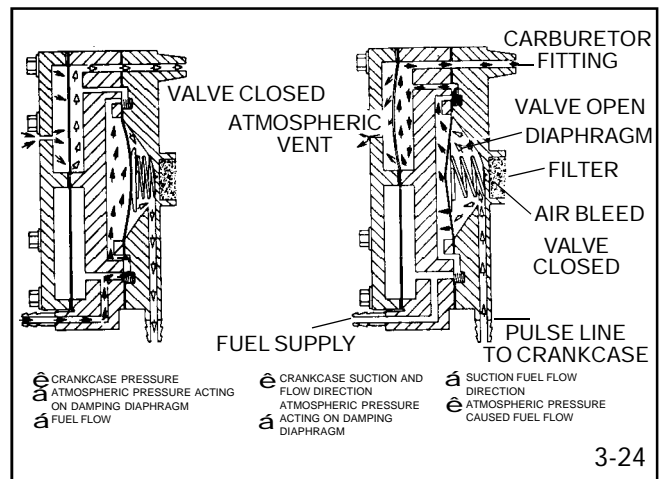

3-24

Fuel Pump Testing: The maximum lift is 24 inches (610 mm). A fuel pump may be tested with our leak test kit part number **670340** or a commercially available low pressure gauge. Connect the low pressure gauge to the fuel inlet fitting. Apply no more than **5 PSI (.35 Bar)** of pressure. The air pressure should pass freely through the pump and out of the fuel outlet fitting. Next, attach the low pressure gauge to the fuel outlet fitting. Apply less than **5 PSI (.35 Bar)** of pressure. Turn off the air valve and watch for any pressure drop. The fuel pump should hold a maximum of **5 PSI (.35 Bar)** for one minute.

NOTE: Do not exceed 5 PSI (.35 Bar) of pressure or fuel pump damage may occur.

CAUTION: DRAIN ALL FUEL INTO AN APPROVED CONTAINER OUTDOORS, AND AWAY FROM ANY OPEN FLAME OR COMBUSTION SOURCE. BE SURE THE ENGINE IS COOL.

NOTE: A crankcase overfilled with engine oil can affect pump operation by splashing oil over the pulse line passage causing erratic pump operation.

IMPULSE FUEL PUMP SERVICE

The valve type impulse pump can be serviced using the following procedure.

1. Remove the pump from the engine noting its exact mounting location and position.
2. Note or mark the pump body alignment by lightly scribing lines at various mating joints. Remove the four screws and disassemble the pump. (Illust. 3-25)



3-25

3. Remove the gaskets, diaphragms, check valves, springs and air filter. (If equipped).

NOTE: Retain the spring bearing. A replacement is not supplied in the fuel pump kit.

4. Clean the body parts with solvent and blow out all passages using compressed air.
5. After drying all parts, install the new check valves with the face of the valve facing the raised portion of the passage. (Illust. 3-26) After installation, cut off the extended portion of the check valve stems flush with the pump body.



3-26

6. Install the diaphragms against the center portion of the body with the gaskets against the outside covers. The parts can only be assembled one way without damage.
7. Install the spring bearing on the new spring and place into position. (Illust. 3-27)
8. Assemble the body sections, install the retaining screws, and torque the screws to **12 - 16 inch pounds (1.36 - 1.81 Nm)**.
9. Install new filter in pump cavity if present.



3-27

CHAPTER 4. GOVERNORS AND LINKAGE

GENERAL INFORMATION

The TVT engine is equipped with an internal mechanical governor. The governor's function is to maintain a R.P.M. setting when engine loads are added or taken away. This chapter includes governor assembly linkage illustrations to aid in governor or speed control assembly.

OPERATION

As the speed of the engine increases, the weights on the governor gear move outward from centrifugal force lifting the governor spool. The contact between the spool and governor rod causes the attached outer governor lever to push the solid link and close the throttle plate. When the engine speed decreases, the lower centrifugal force allows the governor weights to be pulled in by the governor spring. The governor rod rotates and the solid link moves the throttle plate to a more open position. (Illust. 4-1)

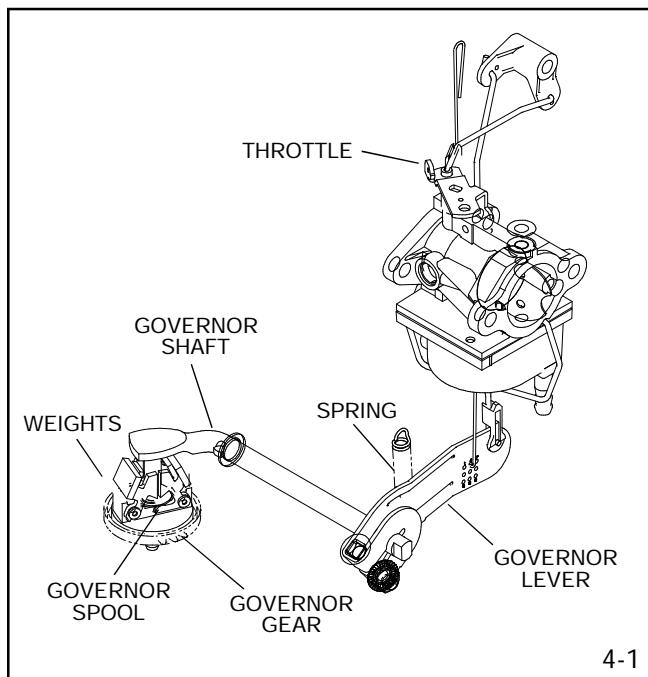

TROUBLESHOOTING

Engine overspeed must be corrected immediately, before serious engine damage occurs. Erratic engine operation where the governor is suspect, may be the result of other engine system problems. Hunting (engine R.P.M. surging up and down) can be an indication of fuel starvation or an air leak. Low power (engine will not hold RPM under load) can indicate, fuel, ignition or internal concerns. Use the following procedure to diagnose a suspected governor problem.

ENGINE SPEED ADJUSTMENTS

Before attempting to set the governed high or low RPM speeds, locate the recommended RPM setting according to the engine model and specification numbers. These specifications can be located on microfiche card # 30 or the computerized parts look-up system.

Start the engine and allow it to warm up to normal operating temperature (3 - 5 minutes). Set the speed control to the low speed position. Check the governed idle speed (**not true idle**). Adjustment is made by bending the governor spring bracket upward to increase the idle RPM or downward to lower idle RPM. (Illust. 4-2)

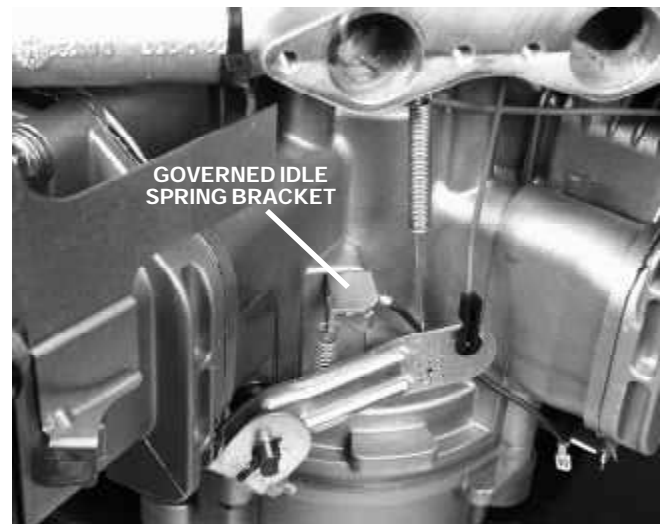

4-2

Set the speed control to the HIGH or FAST position. Check engine speed. To adjust, bend the tang on the control lever upward to increase high speed R.P.M. or downward to lower high speed R.P.M. (Illust. 4-3)

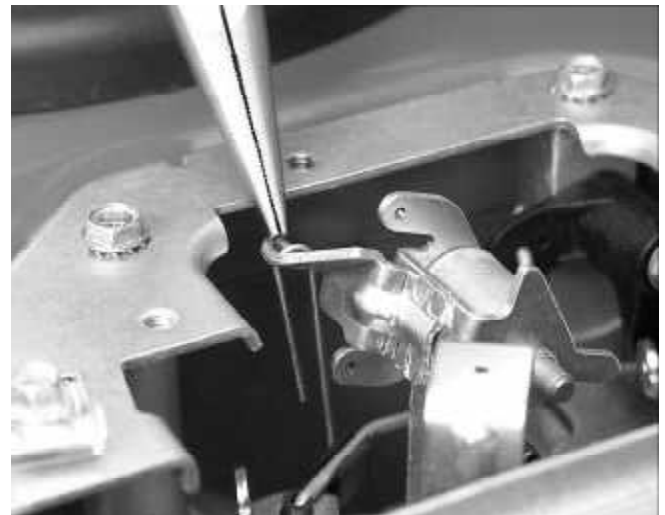

4-3

ENGINE OVERSPEED

1. If the engine runs wide open (faster than normal), shut the engine off **immediately**.
2. Check the condition of the external governor shaft, linkage, governor spring, and speed control assembly for breakage or binding. Correct or replace binding or damaged parts.
3. Follow the governor static adjustment procedure and reset the governor - see "Service" in this chapter.
4. Start the engine. Be ready to shut the engine off if an overspeed condition still exists. If the problem persists, attempt to hold the solid link between the governor arm and the carburetor throttle plate in one position. If this controls the condition, the engine will require disassembly to inspect the governor gear assembly for damage, binding, or wear. See **Chapter 7** under "Disassembly Procedure".
5. Remove the governor gear assembly. Repair or replace as necessary.

ENGINE SURGING

1. Try to stabilize engine R.P.M. by holding the solid link between the bell crank lever and the carburetor throttle plate in a fixed position using a pliers or fingers. (Illust. 4-4)

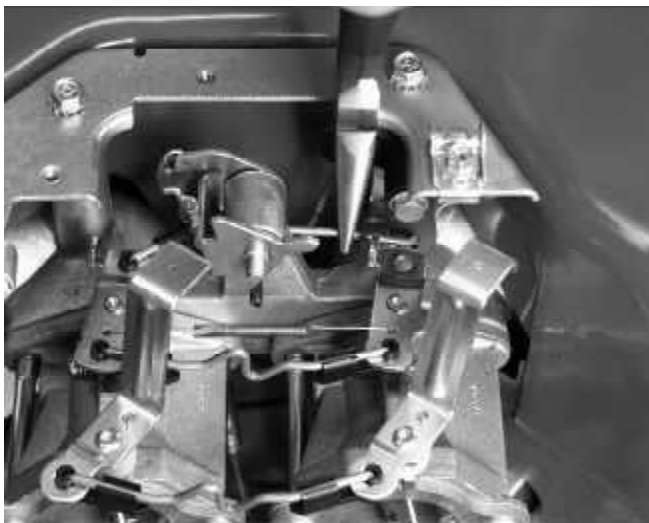

4-4

2. If the engine R.P.M. stabilizes, re-adjust the governor setting. Check the governor shaft, linkage, bushing clips and spring for binding, wear, or improper hookup. Replace as necessary. If none of these correct the problem it may be necessary to disassemble the engine for internal governor repair.
3. If the engine R.P.M. does not stabilize, it may require additional checks of the fuel system, see the fuel system trouble shooting section.

GOVERNOR SERVICE

STATIC ADJUSTMENT - GOVERNOR

With the engine stopped, loosen the screw holding the governor lever to the governor shaft. Push the governor lever up to move the carburetor throttle plate(s) to the wide-open throttle position. Rotate the governor rod counterclockwise. Hold the lever and rod in this position while tightening the screw. (Illust. 4-5)



4-5

GOVERNOR GEAR AND SHAFT SERVICE

After the cylinder cover is removed from the engine, the governor spool, gear, and governor shaft can be removed. A retaining ring must be removed to allow the gear to be removed from the shaft. (Illust. 4-6)

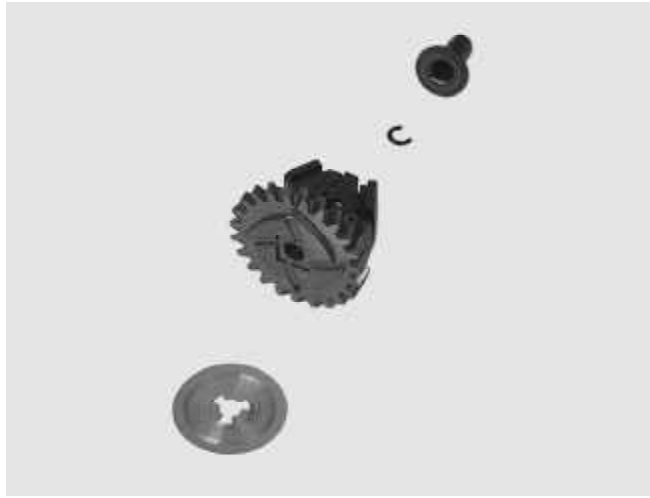

4-6

SPEED CONTROLS AND LINKAGE

The TVT series engine offers the adaptability of throttle cable connection from either side of the engine. Either cable position must pull against the governor spring force, to increase the engines speed. **NOTE:** Both the upper and lower governor spring connections, they must be installed correctly to prevent improper operation. (Illust. 4-7 & 4-8)



4-7

GOVERNOR SHAFT REPLACEMENT

1. Remove the spool, retaining ring, gear assembly and washer(s).
2. Clamp the shaft in a vise and pound gently on the flange with a wooden or plastic mallet to remove the shaft.

NOTE: DO NOT TWIST THE SHAFT WHEN REMOVING. THE SHAFT BOSS MAY BECOME ENLARGED AND THE PRESS FIT WILL NOT SECURE THE NEW GOVERNOR SHAFT.

3. Start the new shaft into the flange boss by tapping with a soft faced hammer.
4. Apply a small amount of red loctite 271 to the lower governor shaft and using a press or vise push the governor shaft into the flange leaving an exposed length of **1.196" (3.969 mm)**.

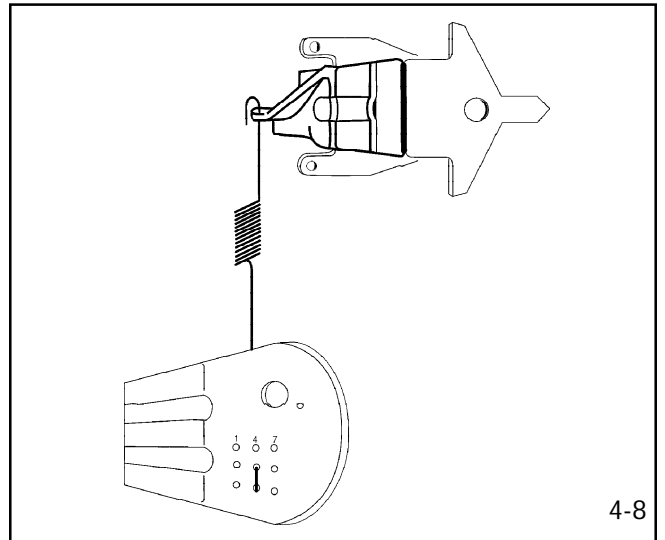

4-8

NOTE: Whenever the carburetor or the governor linkage is removed or replaced, the engines governed R.P.M.'s must be checked. Use microfiche card #30 or the computer parts look-up systems to locate the correct R.P.M. settings for the engine model and specification you are repairing.

SYNCHRONIZING THE CARBURETORS

The TVT series uses twin carburetors, which **MUST** be synchronized if the linkage or carburetor body has been disturbed. The following step by step procedures must be followed to synchronize both the throttle and choke. Inspect all link connectors. If excessively worn or damaged replace them. To perform this service the carburetors must be mounted and all linkage must be connected.

1. Remove the control assembly cover, air cleaner cover, air cleaner, carburetor deflector and air cleaner body from the engine. (Illust. 4-9)



4-9

2. Remove the link connector bushing clip holding the throttle link to the #1 cylinder carburetor. (Illust. 4-10)

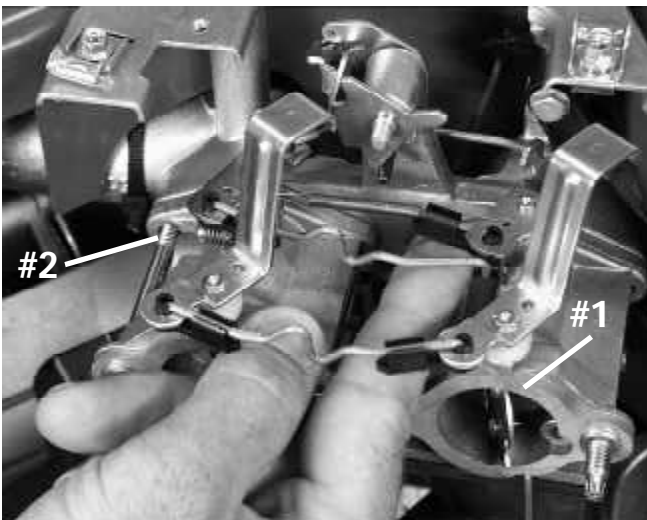

4-10

3. Manually rotate the throttle shaft on the number #2 carburetor to the idle position. Next back out the idle R.P.M. adjustment screw until it no longer contacts the throttle plate tang. (Illust. 4-11)



4-11

4. While holding the number #2 carburetor throttle shaft in the idle position turn in the idle R.P.M. adjustment screw to 1/4 turn past first contact. **NOTE: It is critical to find first contact of the R.P.M. adjustment screw to the throttle plate tang.**
5. With the bushing clip still detached, back out the idle R.P.M. adjustment screw on the #1 carburetor. Hold the throttle plate in the idle position and turn the idle R.P.M. adjustment screw in until first contact with the tang is made. (Illust. 4-12)



4-12

6. Connect both carburetors by attaching the link and link connector bushing clip to the # 1 carburetor.
7. Hold the throttle plate on the #2 carburetor in the true idle position. (Screw against the tang). **NOTE:** Do not set the gap using the idle R.P.M. adjustment screw. Use a **.010" (.254 mm)** feeler gauge to set the air gap between the idle R.P.M. adjustment screw and the throttle plate tang on the #1 carburetor. (Illust. 4-13) The throttle cross link will need to be bent inward (toward the engine) to increase the air gap or pulled outward to decrease. (Illust. 4-14)

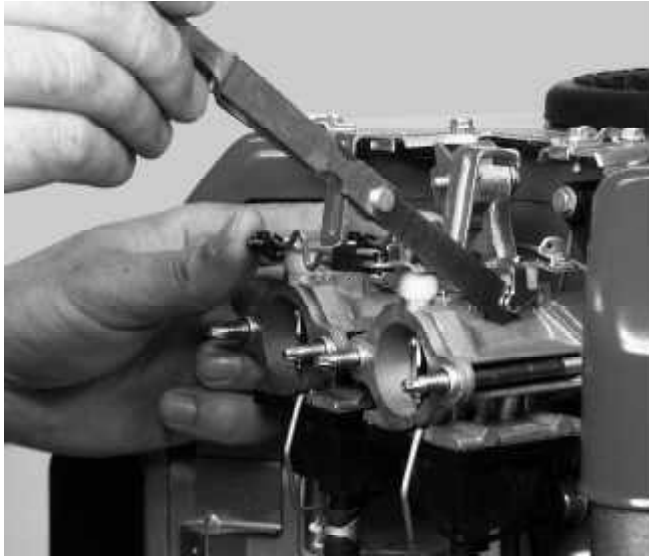

4-13

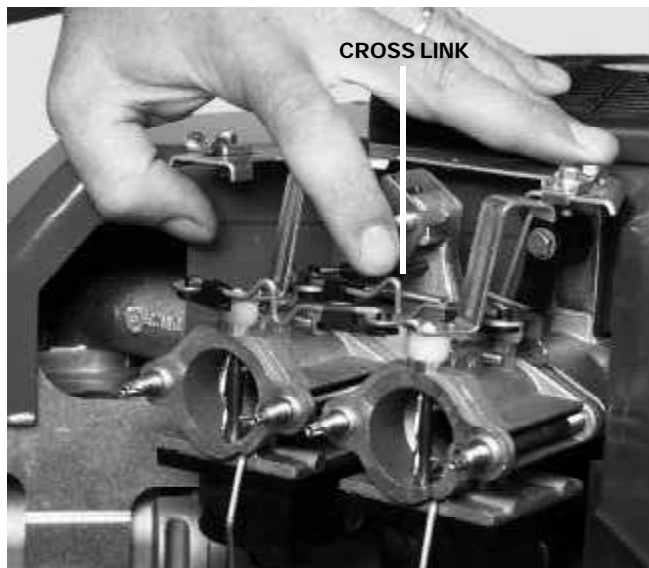

4-14

CHOKE SYNCHRONIZATION

1. Engage the choke control cable of the equipment to the full choke position.
2. Remove the control assembly cover, air cleaner cover, air cleaner and air cleaner baffle. (Illust. 4-15)

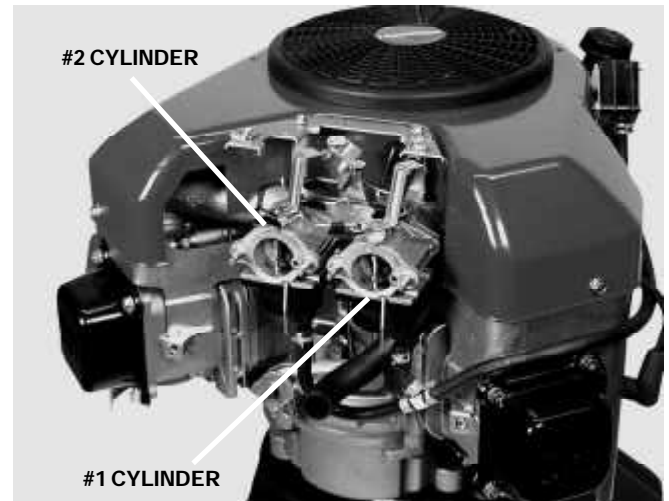

4-15

3. Visually inspect that the choke shutter plate on the # 2 carburetor is completely closed. If the plate is not completely closing, choke cable adjustment is necessary.
4. Apply and hold light pressure closing the choke lever on the #2 carburetor. Attempt to rotate or move the choke plate on the #1 carburetor. (Illust. 4-16) If movement can be found or the choke shutter is not completely closing, the choke cross-link will need to be adjusted. To adjust, bend the cross-link inward towards the cylinder block until both choke shutters completely close at the same time.

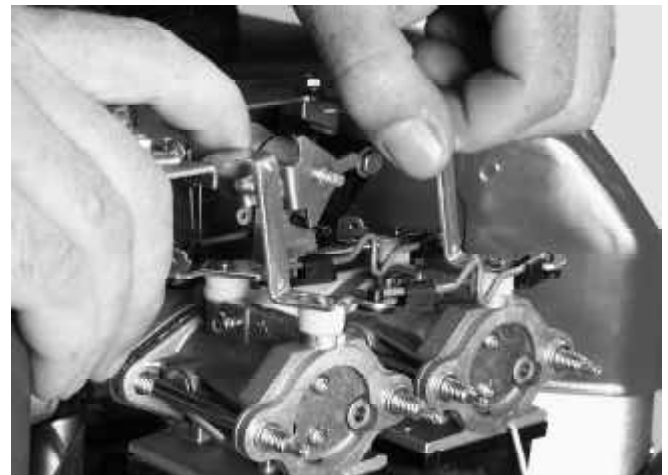

4-16

Re-assemble the components, ensure the cable clamps are tight. Start the engine and allow it to warm up (3-5 minutes). Set the governed idle and top no-load RPM. The correct RPM settings can be located on microfiche card #30 or the computer parts look-up systems. The use of a vibra-tach Tecumseh part **#670156** or a digital engine tachometer part **#670341** will aid in this procedure.

CHAPTER 5. ELECTRICAL SYSTEMS

GENERAL INFORMATION

The electrical system consists of three main elements: a battery, a starting circuit, and a charging circuit. The battery is part of both the starting and charging circuit. Battery voltage should be checked before going into any extensive starter or charging system checks. If a battery has a shorted cell, overcharging can result, and the regulator or rectifier may appear to be at fault. If a cell has an open or high resistance connection, the electric starter operation will be affected.

The power source used to provide the energy to turn an electric starter motor on the TVT series is 12 volt D.C. The 12-volt battery system requires a charging package to maintain proper battery charge.

The starting circuit includes the battery, battery cables, ignition switch, safety switches, starter solenoid, and the electric starter motor.

The charging system consists of alternator charge coils, a diode or regulator, ignition switch, flywheel magnets, and a battery. All engines that have a charging system will use a combination of some or all of these features.

OPERATION

Although most equipment has an electrical system that consists of three main elements, (battery, starting circuit, and charging circuit) they can vary in layout and design from model to model as well as manufacturer to manufacturer.

Within each element there are individual components (battery, wiring, safety switches, ignition switch, solenoid, etc.) which must be diagnosed separately. The illustration shown (Illust. 5-1) is a basic diagram which includes some of the elements used in an electrical system.

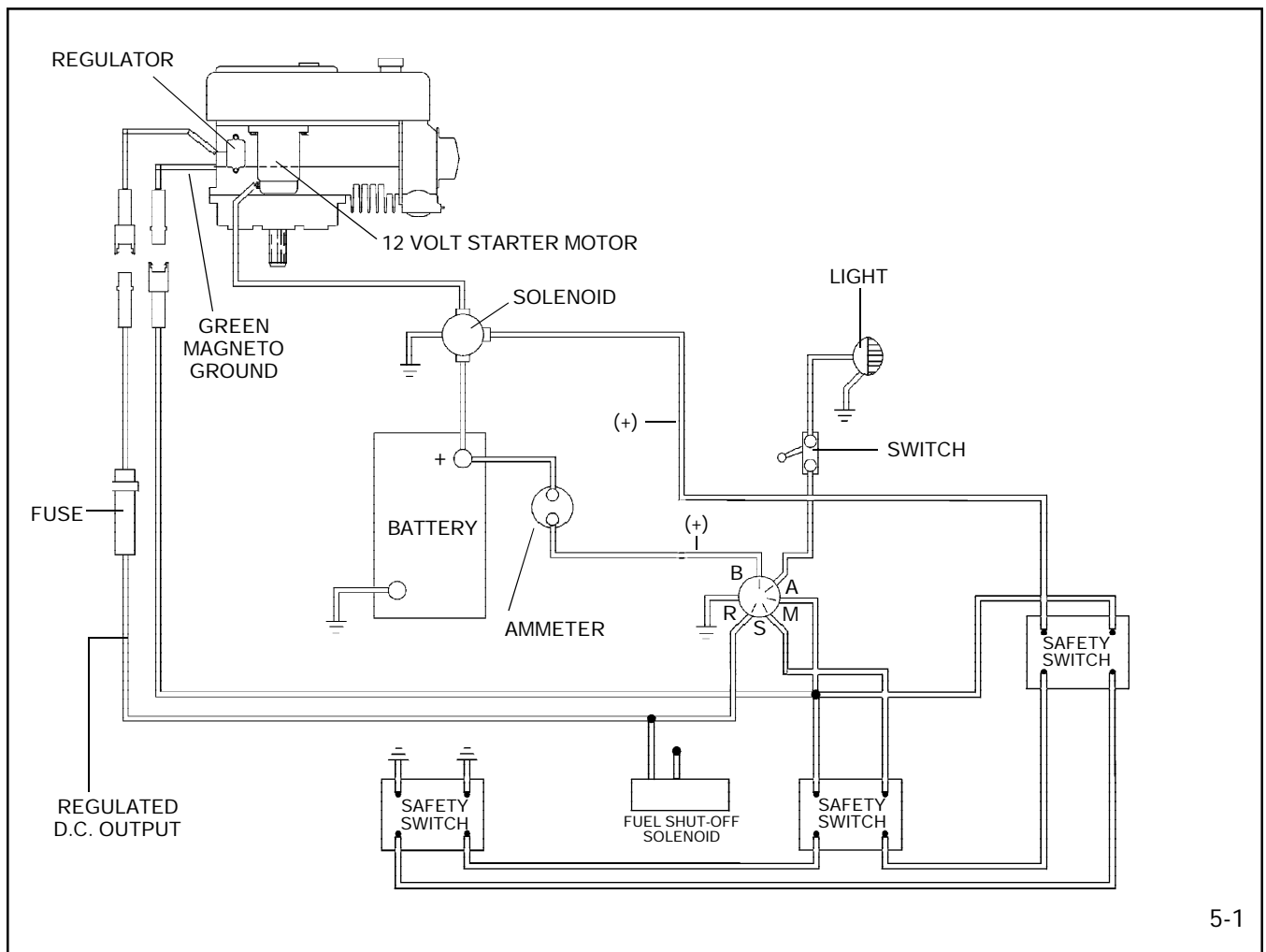

CONVERTING ALTERNATING CURRENT TO DIRECT CURRENT

In order to charge a battery, it is necessary to convert alternating current (A.C.) to direct current (D.C.). This is accomplished by using a diode or rectifier. (Illust. 5-2) A single diode makes use of only one half of the A.C. signal. This is known as HALF WAVE RECTIFICATION. (Illust. 5-3) In certain situations it is necessary to make use of the entire A.C. signal. To accomplish this, multiple diodes in a bridge configuration are used to produce FULL WAVE RECTIFICATION.

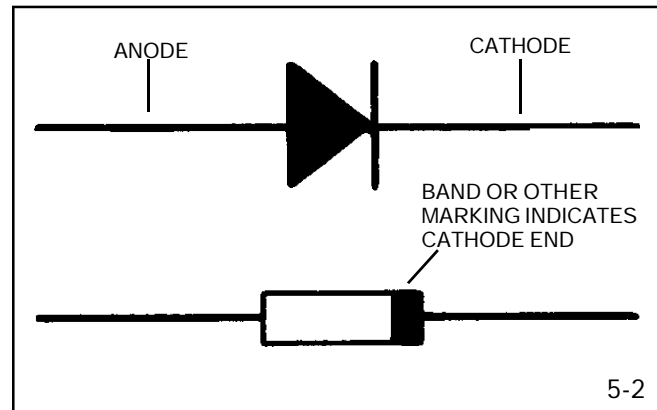

5-2

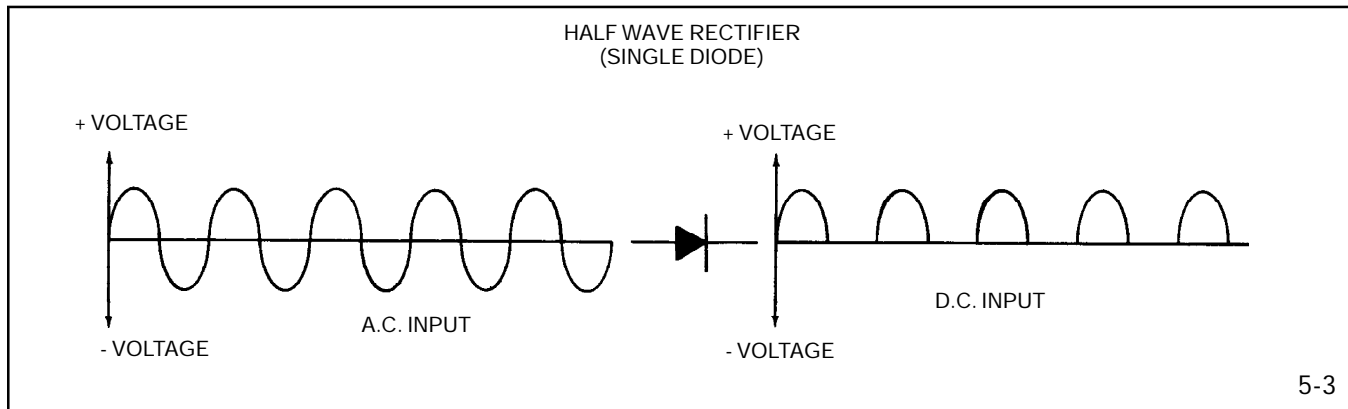

5-3

Current flows through a diode when the anode is more positive than the cathode. The cathode end of the diode should point toward the battery when a diode is used between a charging system and a battery.

Half Wave Rectifier Single Diode

The single diode allows only the positive half of the A.C. signal through. It does not allow the negative portion through.

Full Wave Rectifier Bridge Rectifier

The full wave rectifier makes use of the entire A.C. signal, converting it to D.C.

CONDITION: All wiring must be fully insulated, securely fastened and free of foreign materials (such as rust and corrosion) at the connection points. This is especially important with the use of batteries, as much of the potential may be lost due to loose connections or corrosion. Remember to check the insulation on the wire. All it takes is a pinhole for leakage to "ground out" on the engine or frame. This is of special concern when moisture or water is present.

WIRE GAUGE: The proper thickness of wire is necessary in all electrical circuits. Wire diameter is measured in increments of gauge numbers. As the gauge number of the wire increases, the wire diameter decreases in size. (Illust. 5-4)

COMPONENTS

BATTERY

The batteries used in conjunction with Tecumseh engines are 12 volt lead acid or "maintenance free" style. The chemical energy produced by the dissimilar metals of the battery plates provides an electrical potential that is used to power the electric starter or unit accessories. Consult the original equipment manufacturer's service manual for battery size, capacities, and testing procedure.

WIRING

The wires used in Tecumseh electrical systems are copper stranded with an insulated coating around the copper strands.

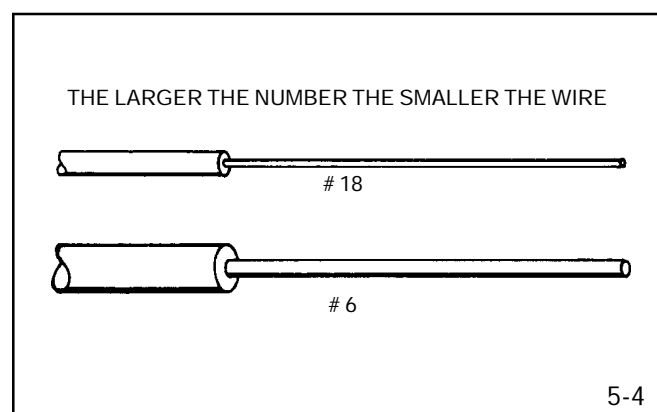

5-4

1. The starter circuit wiring requires a rating of #6 or lower gauge number.
2. The charging circuit wiring requires a #16 or lower gauge number. (20 amp systems requires #14 or lower gauge number).
3. The magneto circuit wiring (ground circuit) requires #18 or lower gauge number.

Tecumseh Products Company's standard wiring color codes effective August, 1992 are as follows:

Code	Product
Yellow	- Alternator A.C. Leads
Red	- Alternator D.C. + Leads
Brown	- Alternator D.C. - Leads
Black	- Alternator Ground Leads, Battery Ground Leads
Orange	- 12 Volt Starter B + Leads
Dark Green	- Ignition Shut-Off Leads

NOTE: Prior to August 1992, wire codes changed according to model and specification numbers.

ELECTRICAL TERMS

ALTERNATOR - An alternator consists of coils of wire wound around a metal lamination stack. When a magnet is moved past the coils, a current is induced in the coils. In general, the greater the number of coils and magnets in the flywheel, the greater the output of the alternator.

RECTIFIERS and DIODES - Charging a battery requires the A.C. (alternating current) produced by the alternator be changed to D.C. (direct current). This is accomplished by using a diode or rectifier.

REGULATOR/RECTIFIERS - This combines a regulator with a rectifier. The regulator controls the amount of current flowing to the battery based on the electrical system need. The rectifier changes the alternating current to direct current.

CONDUCTORS - A conductor is a material that allows an electric current to pass through it. All metals are conductors of electricity, but some are better conductors than others. Silver, copper and gold are some of the better known conductors.

INSULATORS - An insulator is a material that will not allow an electric current to pass through it. Some of the more common materials that are insulators are glass, plastic, rubber, ceramics and porcelain.

BASIC CHECKS

Before going into extensive diagnostics, be sure to perform the more basic checks first, such as:

1. Battery not fully charged or defective.
2. Terminals or connections that are loose or corroded.
3. Cracked insulation or broken wires grounding out.
4. Improper wire connections.
5. Defective ignition switch.
6. Properly functioning Operator Presence System. (Safety Interlocks)*
7. Proper valve lash affecting compression relief.

***NOTE:** All lawn and garden tractors built after July of 1987 are required to have an operator presence system. Many came equipped with such a system prior to this date. If the tractor is "cutting out" or will not start, these switches are a PRIMARY area to check.

CHARGING CIRCUIT

The charging system works independently of any manual controls. The engine needs to be running to produce an electric current flow. When a conductor (alternating coils) cuts the magnetic field generated by the magnets in the flywheel, a current is induced in the alternator coil. The permanent magnets in the flywheel have a magnetic field in which the lines of magnetic force run from the North Pole to the South Pole. As the flywheel rotates and the position of the magnets change, the direction of the magnetic field changes or alternates. The alternating coils are wound in different directions to allow current to flow as an A.C. waveform. (Illust. 5-5)

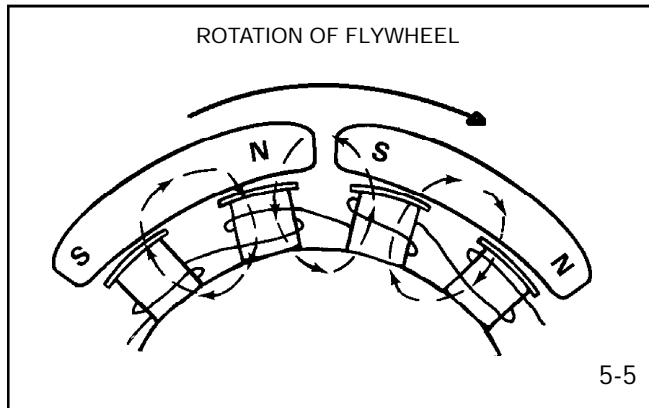

CHARGING CIRCUIT

The charging systems used on the TVT engine is best identified by obtaining the engine model and specification number from the engine. Consult a Tecumseh dealer or a parts manual to correctly identify the charging system. Many of the tests require running the engine and measuring alternator output with a voltmeter. When making voltage tests with the engine running, it is not necessary to take readings at all of the listed R.P.M.'s. Checking at one of the speeds is sufficient.

In some cases an open circuit D.C. check cannot be made. A SCR (Silicon Controlled Rectifier) is located in the circuit which requires a minimum "turn on" voltage to allow it to conduct. Without the battery in the circuit this "turn on" voltage is not present. The SCR "senses" this and there will be no D.C. output from the regulator/rectifier.

Each charging system has its own testing procedure. Test the charging system using the applicable procedure found on the following pages.

3 AMP D.C. 5 AMP A.C. ALTERNATOR

This unit combines a 3 Amp D.C. system used to charge a battery with a 5 Amp A.C. system used for lighting. Located in the red wire of the harness is a diode, which converts the alternating current to direct current for charging the battery. The yellow wire provides the A.C. voltage for the lighting circuit.

A wire harness (**part 36588**) may be added to the 3 Amp D.C. / 5 Amp A.C. charging system to power an electric clutch without the use of a battery. Test the charging system using the applicable "Checking the System" procedure listed in this section. Test the diode in the harness by using a continuity test. (Illust. 5-6) Continuity should exist in one direction only. Replace the diode if continuity exists after reversing tester leads or no continuity is found.

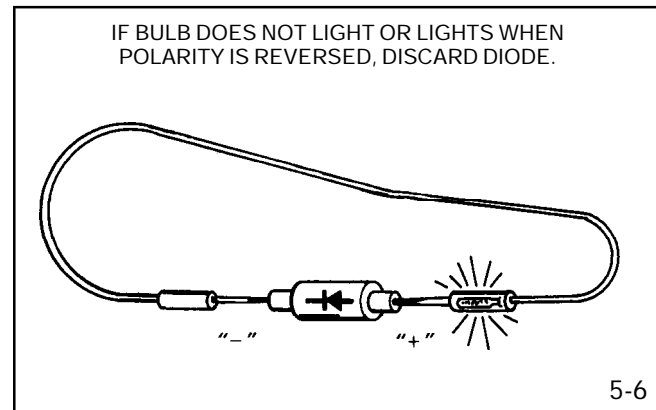

DIODE REPLACEMENT

To replace the diode, disconnect at the plug (spade terminal) and cut the wire on the opposite end of the diode at the solderless (crimped) connector. Remove **1/4" (6.35 mm)** of insulation from the cut end of the wire and twist the strands together. Place the solderless connector from the new diode onto the exposed **1/4" (6.35 mm)** wire and crimp the connector with a standard electrician's pliers. Reconnect the plug end or spade connector.

NOTE: DO NOT USE ACID CORE SOLDER. BE CAREFUL NOT TO APPLY HEAT DIRECTLY TO THE DIODE. USE HEAT SHRINK.

New heat shrink tubing can be installed by slipping over the wires and heating with a heat gun. If this is not available, tape the diode and connections with electrical tape.

CHECKING THE SYSTEM: To check the system, disconnect the plug and measure the D.C. voltage at the red wire terminal. Measure the A.C. voltage at the yellow wire terminal. With the engine running, the minimum values should be:

CAUTION: Follow all Safety precautions when testing for A.C. Voltage, electrical shock can kill.

3 Amp D. C. (Red wire)
6.5 Volts D.C - 2500 R.P.M.
9.0 Volts D.C - 3000 R.P.M.
11.0 Volts D.C. – 3600 R.P.M.

5 Amp A.C. (Yellow wire)
15.0 Volts A.C. – 2500 R.P.M.
18.0 Volts A.C. – 3000 R.P.M.
22.0 Volts A.C. – 3600 R.P.M.

If the above minimum values are noted, the system is okay. Check for defective lights, wiring or switches. If less than above values are noted, pull back the protective shrink tubing from the diode. Using an A.C. voltmeter, check the voltage going into the diode from alternator, at the lead on the alternator side of the diode. (Illust. 5-7) If low or no voltage is experienced, replace the alternator.

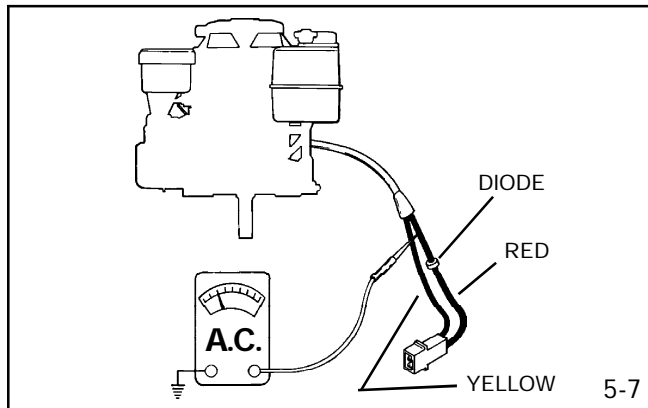

(Read between Engine and Diode)

17.0 Volts A.C. – 2500 R.P.M.
21.0 Volts A.C. – 3000 R.P.M.
24.5 Volts A.C. – 3600 R.P.M.

If low or no voltage is experienced, replace the alternator.
If the alternator puts out the minimum A.C. voltage, replace the diode.

16 AMP ALTERNATOR SYSTEM WITH EXTERNAL REGULATOR

CAUTION: FOLLOW ALL SAFETY PRECAUTIONS WHEN TESTING FOR A.C. VOLTAGE, ELECTRICAL SHOCK CAN KILL.

CHECKING THE SYSTEM: Open circuit D.C. voltage check cannot be made with this system. If a known good battery fails to maintain a charge, proceed to make an A.C. voltage test.

Disconnect the red D.C. output connector at the wiring harness and connect the probes from an A.C. voltmeter to the wire terminals at the regulator-rectifier.

With the engine running, minimum values should read:

21.0 Volts A.C. – 2500 R.P.M.
26.5 Volts A.C. – 3000 R.P.M.
31.0 Volts A.C. – 3600 R.P.M.

If the minimum values are noted, the alternator is operating properly. If less than the above values are noted, the alternator is defective.

TROUBLESHOOTING ELECTRICAL CHARGING CIRCUIT FLOW CHART

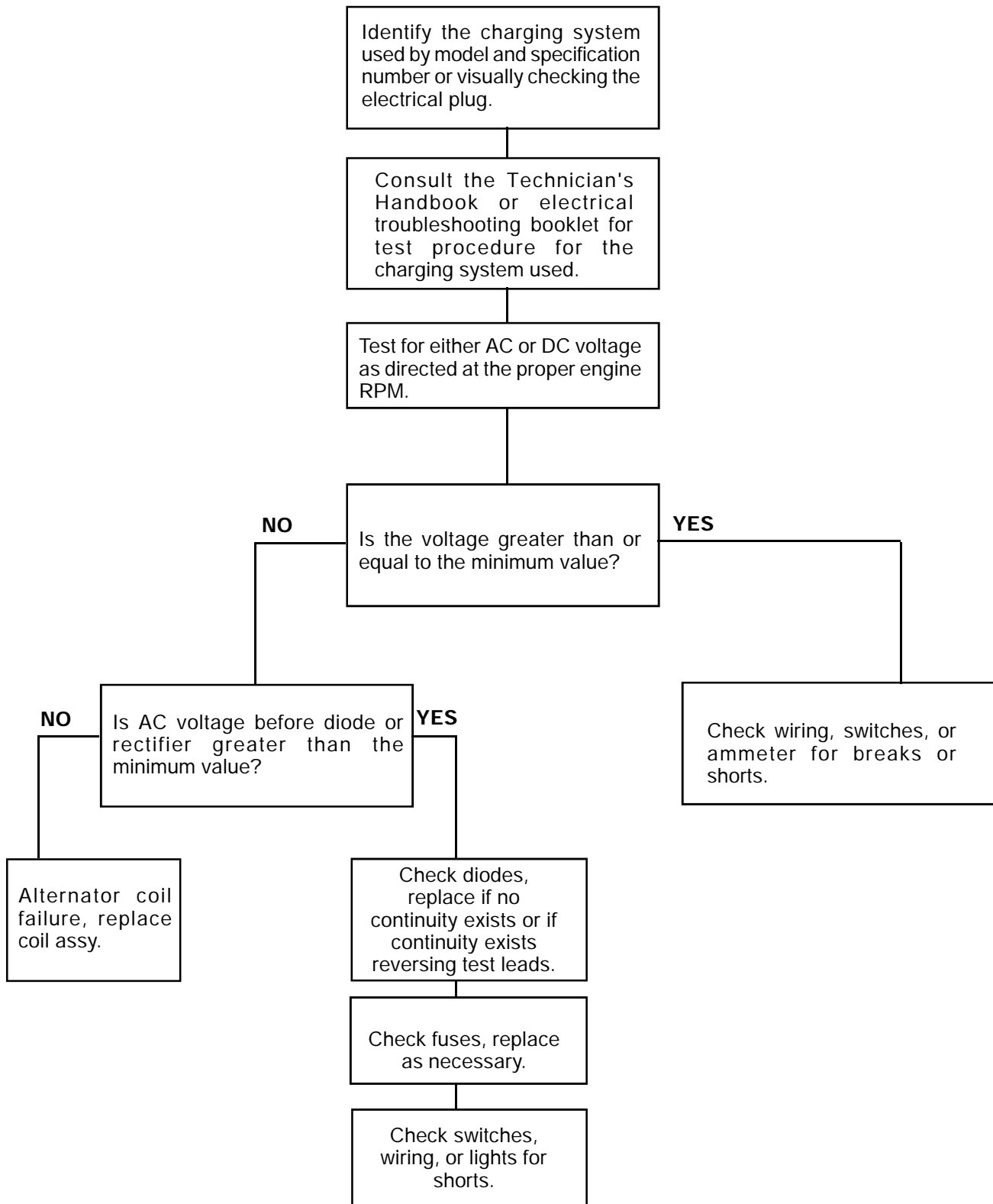

VOLTAGE REGULATORS

If a known good or load tested battery fails to maintain a charge, the charging system and the regulator can be checked using a voltmeter. Set the voltmeter on the 0-20 Volt D.C. scale and connect the probes across the battery terminals. Note the battery voltage. Start the engine, the voltage reading should increase from the noted battery voltage but not exceed 15 volts D.C. If no voltage increase is noted, proceed to make an A.C. voltage check using the applicable procedure. If the battery voltage exceeds 15 volts D.C., or the proper minimum A.C. voltage is noted during the check, replace the regulator. (Illust. 5-8)

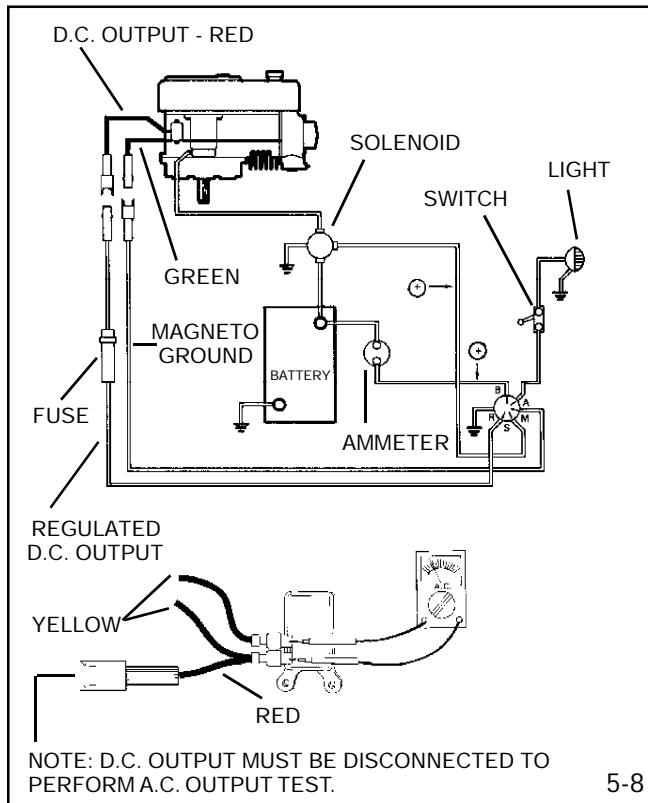

FUEL SHUT-DOWN SOLENOIDS

If the engine is running, the solenoid(s) can be checked by removing the electrical plug-in at the base of the solenoid. Almost immediately the engine should shut down, if not replace the solenoid.

Test the solenoid off the carburetor by applying 12 volt D.C. from the battery positive terminal to a solenoid terminal. Connect a jumper wire from the metal housing (or other terminal) to the negative battery terminal. The plunger should retract the full travel distance. Disconnect the negative jumper lead and the plunger should return to the extended position. (Illust. 5-9)



5-9

LOW OIL PRESSURE SENSOR TESTING

Test the sensor on a running engine using an ohmmeter or continuity tester. Disconnect the wire lead from the sensor. Connect one lead of the tester to the sensor terminal and the other to an engine ground. An open circuit should be found with the engine running and continuity should exist when the engine is shut off. If continuity is found with the engine running or the tractor oil pressure indicator light is on or comes on at low engine RPM's, remove the sensor and check engine oil pressure with a master oil pressure gauge. The oil pressure of a running engine should be above **10 p.s.i. (.700 bar)**. If below **10 p.s.i. (.700 bar)**, an internal engine problem may exist. (Illust. 5-10)

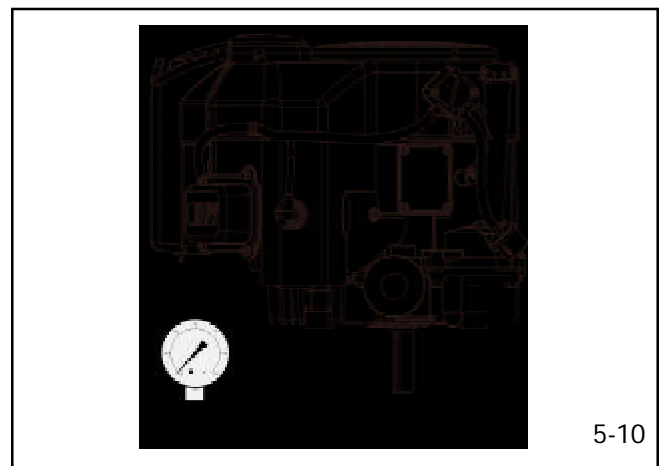

5-7

STARTING CIRCUIT

After all of the safety interlock switches have been activated, the starter switch closes the starting circuit. The electrical current running through the armature windings of the electric starter motor produces a strong magnetic force. The armature magnetism repels the magnetism produced by the permanent field magnets of the electric starter. The repelling magnetic forces cause the armature to rotate, moving the drive pinion laterally on the splined armature shaft. The rotating starter pinion gear then meshes with the flywheel ring gear. When the drive pinion contacts the stop at the end of the armature shaft, the pinion rotates along with the armature shaft to rotate the engine. The armature and pinion remain positively engaged until the engine fires and the flywheel rotates faster than the armature. The greater momentum of the flywheel throws the starter pinion gear out of mesh and forces the starter pinion back to the disengaged position. After the switch is released, the starting circuit is opened and the armature coasts to a stop. A small anti-drift spring holds the pinion in the disengaged position.

TESTING PROCEDURE STARTING CIRCUIT

⚠ CAUTION: FOLLOW ALL SAFETY PRECAUTIONS WHEN TESTING FOR A.C. VOLTAGE, ELECTRIC SHOCK CAN KILL.

1. Check the battery using an electrical load tester and following the tester's recommended procedure. Make sure the battery meets the minimum battery voltage requirements found in the original equipment manufacturer's service manual.

NOTE: Load testers drawing no more than 50-60 amperes should be used.

2. Check the electric starter terminal for the required voltage (12 v D.C.) using a voltmeter. (Illust. 5-10)

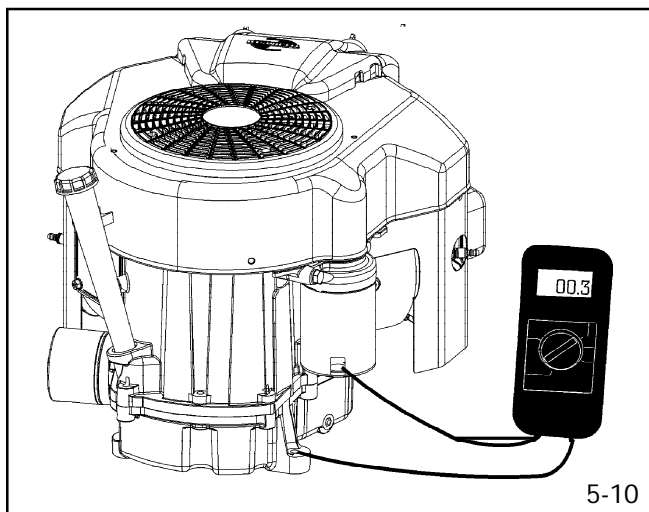

3. Check wiring, connections, circuit breakers, fuses, ignition or starter switch, safety switches, and solenoid for continuity using an ohmmeter or continuity light. Repair or replace as necessary.

4. Isolate the engine from the equipment it is powering. Remove all equipment loads (belts, chains, and couplers). **TEMPORARILY BY-PASS THE SAFETY INTERLOCK DEVICES.**

NOTE: ALL safety switches must be in proper working condition. Repair or replace as needed.

5. If the engine binds only on the compression stroke, check the valve clearance per the specification table in Chapter 10. If the valve clearance is within the specifications, the compression release may require service. To diagnose the camshaft compression release, remove both valve covers and bring the engines number one cylinder up to TDC on the compression stroke. The exhaust valve should briefly open just before TDC. Repeat this procedure on the number two cylinder. If either of the exhaust valves do not open disassembly and removal of the camshaft will be required. See Chapter 7. Valve clearance not within the listed specifications will require adjustment of the rocker arms to obtain the proper clearance.

If the engine turns over freely, the electric starter should be replaced or disassembled and repaired if allowed under various country regulations. See "Service" in this chapter. If the preceding steps fail to correct the problem, the engine will require to be disassembled to find the mechanical failure. See Chapter 7 under "Disassembly Procedure".

If the engine does not turn over, a mechanical binding may be the cause. Check for proper lubrication, (oil level and viscosity) check the electric starter gear and flywheel ring gear interference. If no problem is discovered, the problem is an internal failure.

TROUBLESHOOTING ELECTRICAL STARTER CIRCUIT FLOW CHART

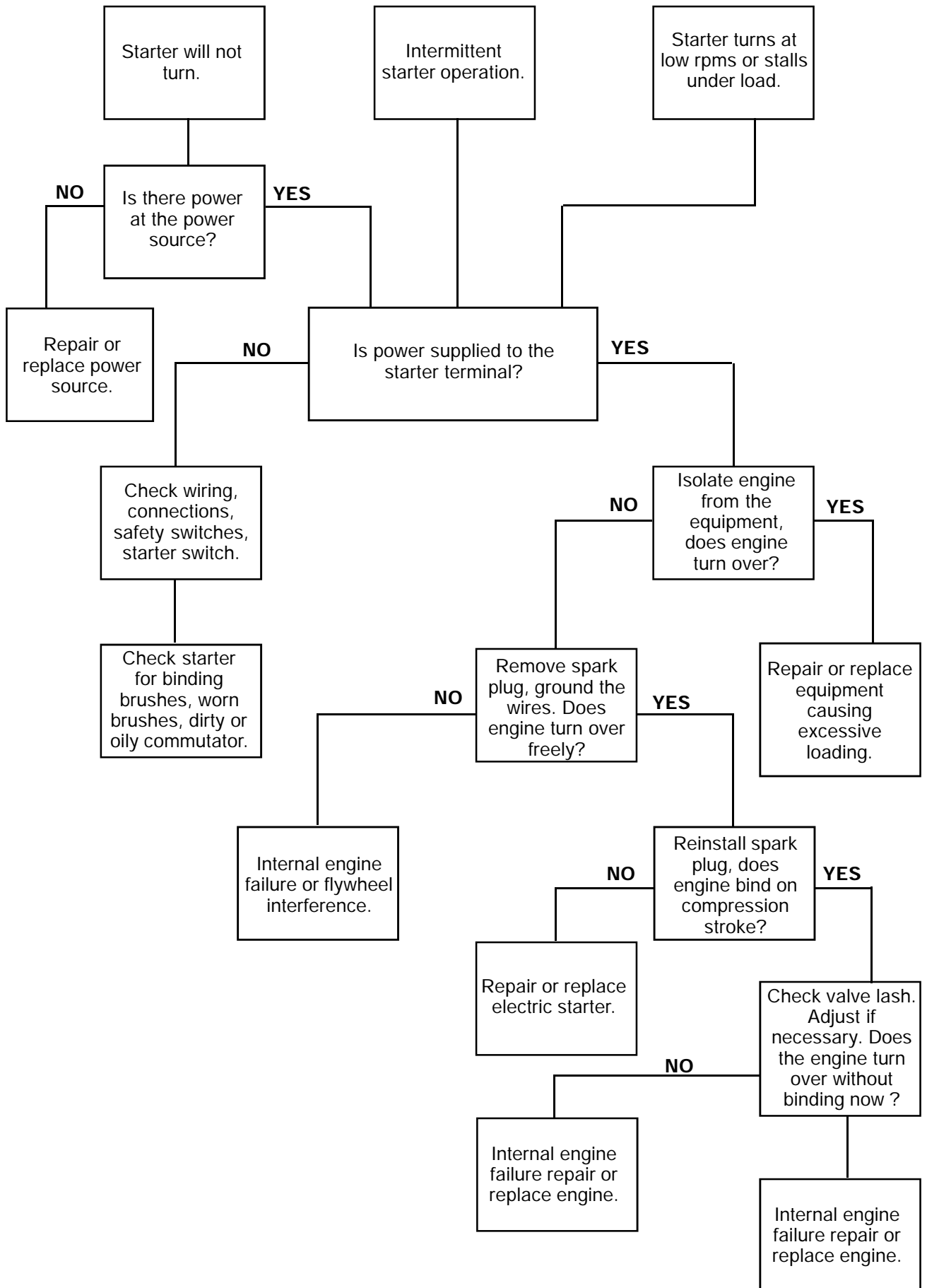

ELECTRIC STARTER SERVICE

This section covers the service procedures for 12 volt electric starters. For diagnosis of the starting circuit see “**Electrical Starter Troubleshooting**” in this chapter.

NOTE: Internal service may not be allowed under various country regulations. Outside the USA consult your local government authorities regarding servicing regulations.

12 VOLT ELECTRIC STARTERS

1. Remove the plastic dust cover on the bendix end. (Illust. 5-12)



5-12

2. Push down on the spring retainer and remove the retaining ring. (Illust. 5-13)



5-13

3. Slide off the spring retainer, anti-drift spring, gear, and drive nut. (Illust. 5-14)



5-14

4. If internal service is necessary (**non-CSA starters only**), scribe a line across the cap assemblies and armature housing to aid in reassembly. (Illust. 5-15)



5-15

5. Remove the through bolts holding the commutator end cap assembly on. (Illust. 5-16)



5-16

6. Slide off the end cap assembly. The starter terminal post insulator slides out of the commutator cap on some models. (Illust. 5-17)



5-17

7. Remove the armature.
8. Inspect and replace as necessary, see the section "Inspection and Repair" later in this chapter. Use the reverse procedure for assembly. For ease of assembly, place the armature into the brush end of the frame first.

INSPECTION AND REPAIR

1. The pinion gear parts should be checked for damage or wear. If the gear does not engage or slips, it should be washed in solvent (rubber parts cleaned in soap and water) to remove dirt and grease, and dried before reassembly. Also check the armature and drive nut splines for wear or damage.
2. The brushes and brush cardholder should be checked for wear. With the armature placed in the commutator end cap, and the brushes engaging the commutator surface, check the brushes for wear. Brushes should be replaced if the brush wire approaches the bottom of the brush holder slot. Brush springs must exhibit enough strength to keep tension on the brushes and hold them on the commutator.
3. Using a continuity light or OHM meter, check field by attaching one lead to each of the field coil connections. Continuity should exist between these two points. (Illust. 5-18)



5-18

- Use a continuity tester to make certain no continuity exists between the commutator copper and the iron of the armature. Rotate the armature and check out all of the commutator bars. (Illust. 5-19)



5-19

- The armature should be checked for glazing or wear. If necessary the armature can be turned down in a lathe. While rotating, polish the commutator bars using a piece of 00 sandpaper. (Illust. 5-20) Light pressure and back and forth movement should be used. Re-cut the commutator bars to a depth equal to the width of the insulators between the bars.

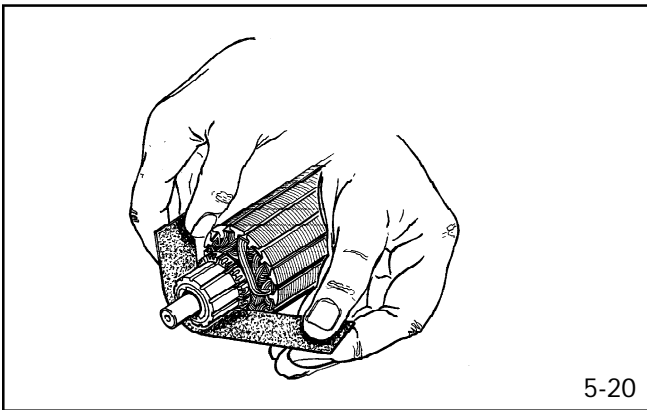

5-20

BRUSH HOLDER

Install finishing nails into a block of wood according to the following diagram. (Illust. 5-21)

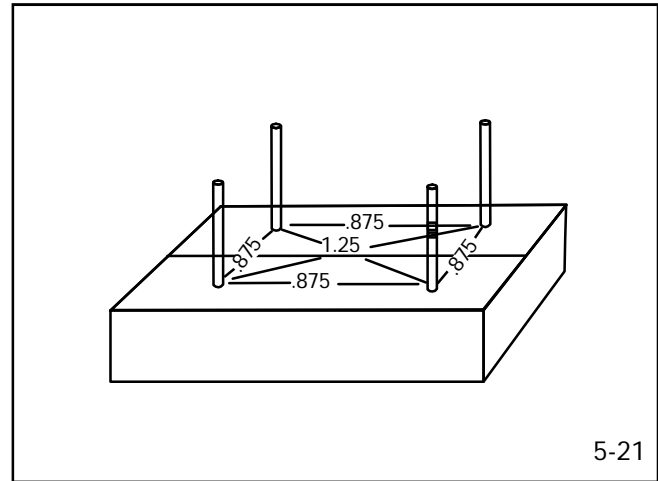

5-21

BRUSH REPLACEMENT

- Remove the thru bolts holding the end cap in place.
- Remove the end cap and thrust washer from the starter housing.
- Note or mark the position of the brushes.
- Remove the holding nut from the starter terminal post and remove the post and two brush leads.
- Remove the remaining two brushes by sliding the retaining clips off the metal end cap.
- Install the new brushes and springs onto the end cap.
- Spread back the brushes and using the brush holder tool. Install the brush holder from the bottom up through the end cap.
- Install the thrust washer on the end of the armature shaft.
- Install the starter end cap. Secure with the thru bolts and remove the brush holder. Rotate the armature by hand to check for binding before installation on the engine.

CHAPTER 6. IGNITION

GENERAL INFORMATION

The ignition system consists of flywheel magnets, flywheel key, charge coil, capacitor, resistor, a silicon controlled rectifier, pulse transformer, trigger coil, high tension lead, and a spark plug. Everything except the flywheel magnets, flywheel key and spark plugs are located in an encapsulated solid state Capacitor Discharge Ignition module (CDI), outside of the flywheel. This system requires no maintenance other than periodic inspection of the spark plugs and high-tension leads.

OPERATION

SOLID STATE IGNITION SYSTEM (CDI)

As the magnets in the flywheel rotate past the charge coil, electrical energy is produced in the module. The energy is stored in the capacitor (approx. 200 volts) until an electrical switch (SCR) releases it. As the magnet continues to rotate, it passes a trigger coil where a low voltage signal is produced. This low voltage signal closes the SCR switch, allowing the energy stored in the capacitor to flow to a transformer where the voltage is increased from 200 volts to 25,000 volts. This voltage follows along the high-tension lead to the spark plug where it arcs across the electrodes and ignites the air-fuel mixture. (Illust. 6-1)

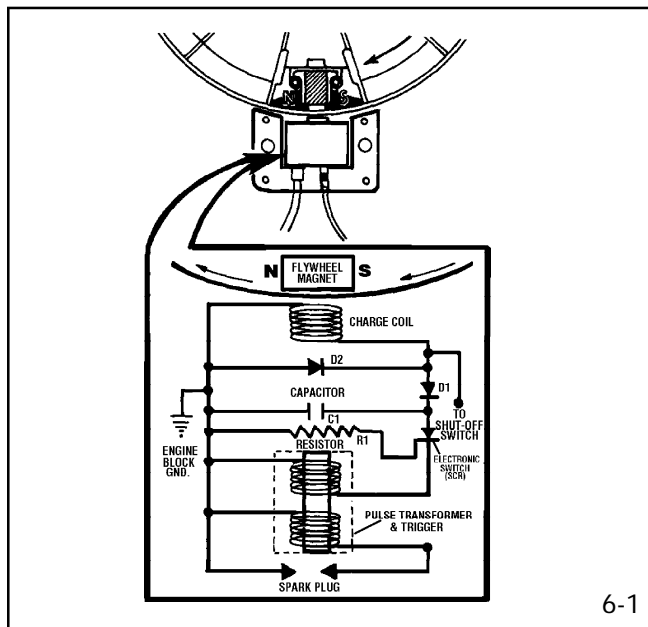

COMPONENTS

The **solid state module (CDI)** is a complete unit that includes the laminations, SCR, capacitor, resistor, pulse transformer, charge coil, trigger coil, and spark plug high tension lead.

The **spark plug** is made up of two electrodes. The outside electrode is grounded and secured to the threaded sleeve. The center electrode is insulated with porcelain. The two are separated by an air gap, which creates a resistance. A large voltage from the module arcs the air gap, which causes a spark and ignites the air-fuel mixture in the cylinder. (Illust. 6-2)

NOTE: Always consult parts breakdown for the correct spark plug and reach.

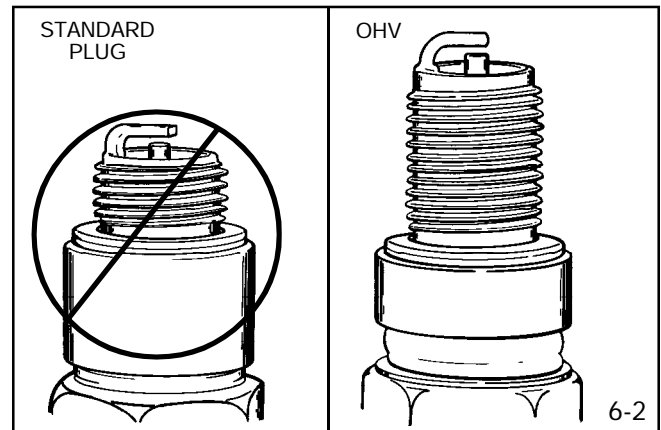

The **flywheel** holds the flywheel magnets in a constant position. It also provides rotational mass to smooth out the effects of the engines power stroke.

The **flywheel magnets**: provides the magnetic flux (or field) which is necessary to induce voltage and trigger the module to provide spark.

The **flywheel fins** create air flow to cool the engine.

The **flywheel key** locates the flywheel to the crankshaft in the proper position for ignition timing. **Note:** A sheared or partially sheared flywheel key can cause kickback or a No start condition.

NOTE: Always replace flywheel keys by model and specification number. Keys that look similar may have different timing dimensions or shear strengths.

TESTING PROCEDURE

1. Check for spark using an ignition tester and following the tester's recommended procedure. **NOTE:** The ignition will have spark even with a sheared key, but the timing will not be correct.

 **CAUTION: KEEP ALL COMBUSTIVE SOURCES AWAY. AVOID THE SPRAY FROM THE SPARK PLUG HOLE WHEN CRANKING THE ENGINE OVER AND MAKE SURE THE PLUG WIRES ARE PROPERLY GROUNDED TO THE DEDICATED RETAINING POSTS.**

2. Check the spark plugs for proper reach, cracks in the porcelain, pitted or burned electrodes, excessive carbon buildup, and proper **.030" (.762 mm)** air gap setting. Replace if questionable. Attempt to start and run the engine. If the engine will not start or run properly proceed to step #3.
3. Attach the spark plug wire(s) to an ignition tester and ground the tester(s) as in step #1. Remove the blower housing, disconnect the ignition grounding leads at the ignition modules. Reinstall the blower housing for safety and crank the engine over. If spark occurs, check the ignition switch, safety interlock switches, or electrical wiring for shorting to ground.
4. Check the air gap between the flywheel magnets and the laminations of the ignition modules. It should be **.0125" (.3175 mm)** use gauge part 670297. (Illust. 6-3)

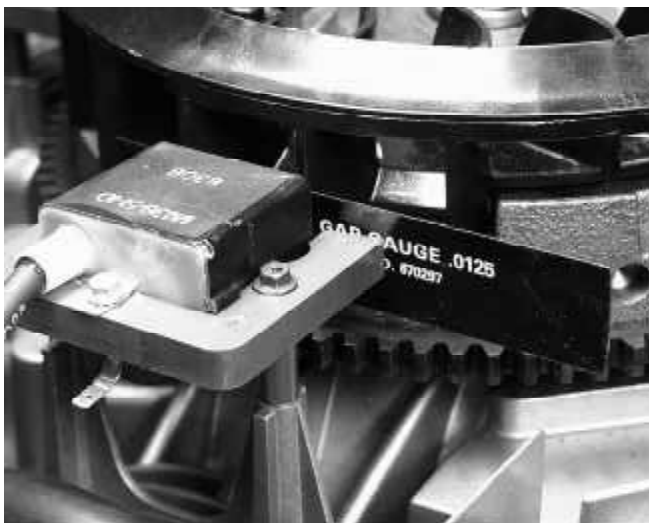

6-3

5. Check the flywheel magnets for the proper strength. Hold a screwdriver at the extreme end of the handle with the blade down, move the blade to within **3/4 inch (19.05 mm)** of the magnets. If the screwdriver blade is attracted to the magnets, the magnetic strength is satisfactory. (Illust. 6-4)



6-4

6. Examine the ignition modules and lamination assembly for cracks in the insulation or other damage, which would cause shorts or leakage of current.
7. Check the operation of the ignition module using an approved tester following the instructions furnished with the test unit.

Ignition modules are permanently attached to the lamination and must be serviced as an assembly.

SERVICE

SPARK PLUG SERVICE

Spark plugs should be removed, inspected and adjusted periodically. Replace the spark plugs every 100 hours or annually.

Check the air gap(s) with a spark plug gap gauge and adjust accordingly. Set the spark plug gap at **.030" (.762 mm)**. (Illust. 6-5)

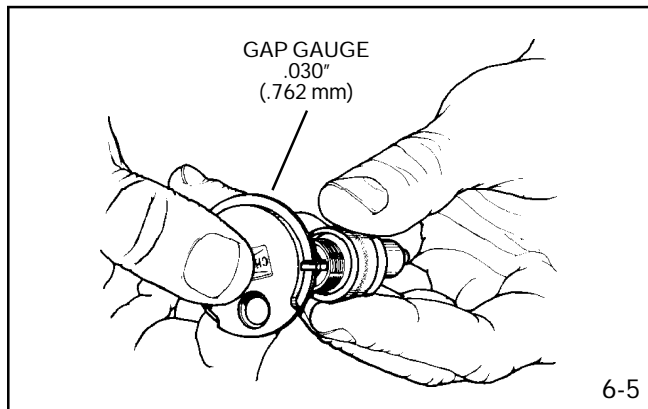

Replace the plug if the points on the base of the plug are pitted or burned, or if the porcelain is cracked anywhere. When reinstalling the plug make sure it is clean and free of all foreign material.

NOTE: NEVER use a sand blaster to clean plugs, microscopic particles left in the plug can score the engine cylinder during operation. Use a solvent and a wire brush to clean. Using eye protection, blow out thoroughly with compressed air.

Replace the spark plug with the proper spark plug. Consult the parts breakdown for the spark plug to be used in the engine being serviced.

Install the spark plug, being careful not to cross thread. Tighten the spark plug to **21 foot pounds (28 Nm) of torque**. If a torque wrench is not available, turn the spark plug in as far as possible by hand, then use a spark plug wrench to turn the plug 1/2 turn further. If installing a used plug, only 1/8 to 1/4 turn after seat is needed.

CONDITIONS CAUSING FREQUENT SPARK PLUG FOULING

1. Air cleaner is restricted. (Replace)
2. Partially closed choke shutter. (Check operation)
3. Poor grade of gasoline. (87 octane minimum)
4. Improper fuel. (Old, stale or mixed)
5. Restricted exhaust system. (Remove and inspect muffler for restrictions or loose baffles)
6. Incorrect spark plugs. (Check reach and number)
7. Incorrect spark plug gap. (Adjust gap)
8. Oil level is too high, or the breather is restricted.
9. Worn piston rings.
10. Weak ignition system. (Air gap too wide, partially grounding wires or faulty safety switches)

IGNITION TIMING

In order for an engine to run efficiently, the spark must ignite the compressed air-fuel mixture when the piston is in a specific position to deliver maximum power. This position is known as Before Top Dead Center (BTDC). If the mixture is ignited too soon, kickback can be experienced due to pre-ignition. If the mixture is ignited too late, loss of power can be experienced due to retarded spark. A partially sheared or the wrong flywheel key can cause kickback, loss of power, or an inability to start the engine. Check the flywheel key if one of these symptoms exist. See Chapter 7 under "Service" for the disassembly procedure.

Timing on a solid state module is not adjustable. The proper air gap of **.0125" (.3175 mm)** using Tecumseh part 670297 and the correct flywheel key in good condition are the only timing variables. Set the gap by placing the gauge between the flywheel magnets and the laminations of the module. Tighten the mounting screws to **45-in. lbs. (5 Nm)**. Remove the air gap gauge and rotate the flywheel slowly by hand to check for any possible striking points. (Illust. 6-6)



6-6

SERVICE TIPS

DO NOT:

- Interchange flywheels, flywheel keys, or spark plugs.
- Use flywheel fans with cooling fins that are damaged or broken off.
- Use a standard business card as an air gap gauge.
- Attempt to attach the spark plug lead back into a solid state module.
- Store a solid state module within **20 feet (6.1 meters)** of an unshielded welder.

CHAPTER 7. INTERNAL ENGINE AND DISASSEMBLY

GENERAL INFORMATION

This chapter covers the cylinder block, piston and rod assemblies, cylinder heads, crankshaft, camshaft, valve train, breather, cylinder cover, flywheel, and lubrication systems. The internal governor systems are covered in Chapter 4.

The TVT series engines are made using aluminum alloy die cast around a cast iron cylinder liners.

LUBRICATION SYSTEMS

The TVT series engine uses an automotive type rotary pump. Oil is drawn up to the pump from the pump inlet screen area in the mounting flange cover/sump. Oil is then pressurized and directed through the oil filter (if equipped). This engine differs from OHV single cylinder models in that the flange cover/sump bearings are also pressure lubed.

From the oil filter the oil flows through the feed passages to all crankcase bearings starting with the lower cam and lower main bearing. The crankshaft has an undercut around the bearing surface, which aligns with the oil feed galley passage. The drilling of the crankshaft creates the passage to the connecting rod bearings and the upper main bearing. The upper camshaft bearing is fed oil by a passage from the upper main bearing. See flow passage (Illust. 7-1)

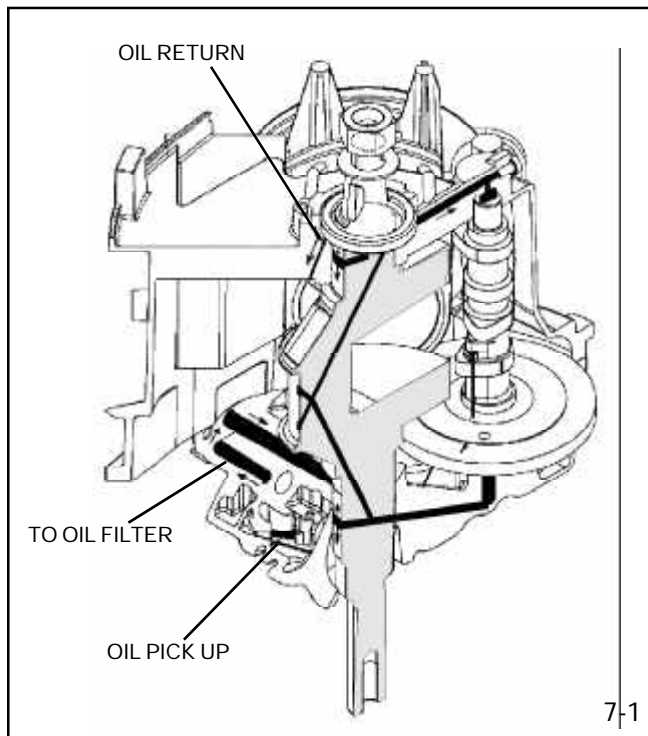

DISASSEMBLY PROCEDURE

1. Disconnect the high-tension leads from the spark plugs. Remove the spark plugs. Evaluate each of the spark plug(s) condition, for tips on areas specifically in need of repair.
2. Drain the oil from the crankcase. Drain or shut off the fuel supply and disconnect the fuel line at the pump or carburetors.
3. Remove the negative battery lead. Remove the positive cable to the starter. Unplug the charging/ignition shut-off wires and the fuel shut-off solenoid wires.
4. Remove the electric starter motor from the engine.
5. Disconnect the exhaust system from the engine.
6. Remove the air cleaner assembly. (Cover, Filters, deflector, control cover and air filter body). (Illust. 7-2)



7. Remove the flywheel-rotating screen.
8. Remove the blower housing by first removing the screw holding the dipstick tube and fuel pump to the blower housing. Remove the remaining three bolts holding on the blower housing.
9. Unplug the ignition ground wire from the terminal on top of the ignition modules and remove the ignition modules.
10. Locate the piston at top dead center (TDC) on the number one cylinder (lowest cylinder) at the compression stroke for easier valve train service.

11. Remove the flywheel nut, washer, and fan. Use part 670305 strap wrench to hold the flywheel from turning. (Illust. 7-3) Thread a flywheel knock-off tool part 670329 (3/4") on the crankshaft until it bottoms out, then back-off one complete turn. Apply light upward pressure under the flywheel using a screwdriver or prybar. **NOTE:** Avoid contact with the alternator coils or internal flywheel magnets. Tap sharply and squarely on the knock-off tool to break the flywheel loose. If necessary, rotate the flywheel a half turn and repeat until loose. (Illust. 7-4)

NOTE: Do not use a jaw type puller to remove flywheel.



7-3



7-4

12. Remove the flywheel key and alternator charge coil.
13. Mark all governor linkage positions, or draw a sketch of their positions to help in re-assembly. See Chapter 4, Governor & Linkage.

14. Remove the governor spring. Separate the link connector bushing clip from the throttle link at the governor lever. (Illust. 7-5)



7-5

15. The intake manifold may now be removed as a complete assembly (manifold and carburetors). Disconnect the remaining wiring harness connections and remove the four intake mounting screws.

16. Remove the rocker arm covers exposing the valve train. The covers and cylinder head assembly are best removed one at a time to prevent a mixture of parts from one to another.

Removal of the push rod guide plate is required to access one of the head bolts. Remove the rocker arms by first loosening the locking jam nut, then removing the rocker stud followed by the rocker arms, rocker guide plate, and push rods (Illust. 7-6). Remove the head bolts, head, and head gasket.

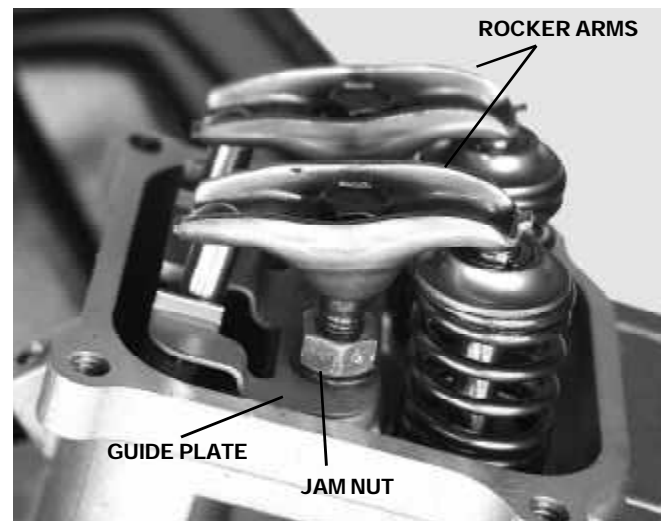

7-6

17. Remove the crankcase breather cover plate, reed valve and limit plate. **NOTE:** The reed valve is notched. This notch must face the cylinder head side of the engine for proper function. (Illust. 7-7)

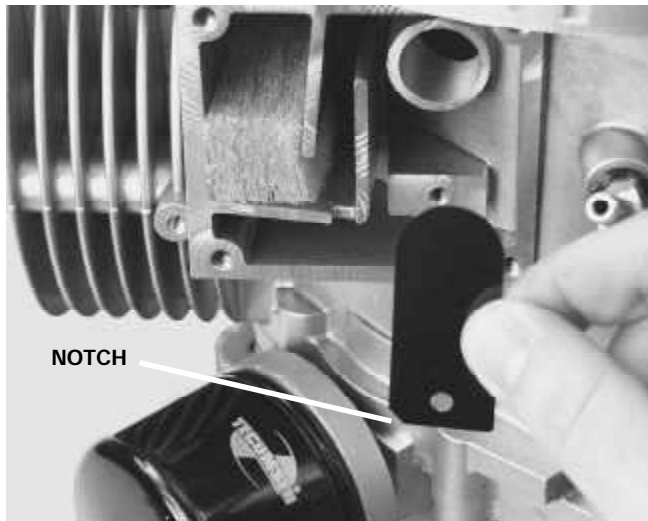

7-7

Also note the breather element. It consists of three sections separated by blue lines. These lines must be in a vertical position when installed into the breather cavity.

18. Using a 670330 seal protector remove the cylinder flange cover/sump with the oil pump in tact. The crankshaft must be free of rust or scale to slide the flange cover/sump over the crankshaft. (Illust. 7-8)



7-8

19. Remove the camshaft and lifters. It is not necessary to mark the lifters as to their original location.

20. Before removing the connecting rods and pistons, scribe a mark on both the connecting rod and rod cap of the assembly nearest the PTO side. This marking will aid in reassembly, assuring the correct rod cap is mated with the correct rod and cylinder bore. (Illust. 7-9) Also remember to remove any carbon build-up from the top of the cylinder bore before piston removal.



7-9

21. Use a **670330** seal protector on the flywheel end crankshaft seal, and remove the crankshaft.

NOTE: Removal of one piston and connecting rod assembly must be accomplished before the crankshaft can be removed.

DISASSEMBLY OF CYLINDER HEADS

Before beginning service of the cylinder head check for warpage by placing the head on a precision flat surface. If warped in excess of **.005" (.127 mm)**, replace the head. Slight warpage can be corrected by placing a sheet of #400 wet /dry sandpaper on a precision flat surface and rubbing the head gasket surface in a circular pattern until the entire gasket surface shows evidence of sanding. A small amount of honing oil on the sandpaper will make it easier to slide the head. Always replace the head gasket and torque the head bolts to specification in **60-inch pound (6.7 Nm)** increments, following the torque sequence in (Illust. 7-10).

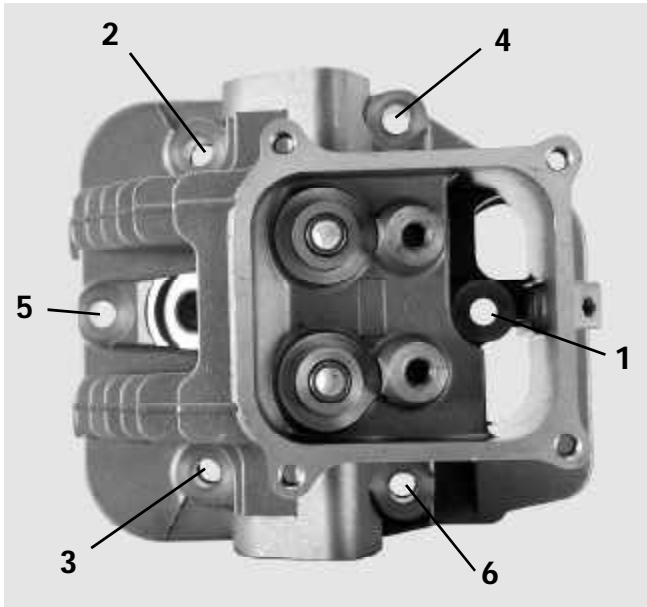

7-10

NOTE: When servicing the valves, all carbon should be removed from the valve head and stem. Before attempting to remove the valves check that the top of the stem is free of burrs. If you find burrs or a lip use a file to break the edge then remove the valve.

Disassembly of the cylinder heads is best done one at a time to prevent mixing valves from one head to the other. Place a shop towel or other similar soft product under the valve heads to prevent damage. You may remove the valve spring retainers from the head using a commercially available valve spring compressor, (Illust. 7-11) or to release the valve keepers from the retainer, tap the retainer with a **3/4" (19 mm)** deepwell socket and hammer. (Illust. 7-12) Be careful not to strike too hard which could push the valve head into the surface causing damage.



7-11



7-12

VALVES

Specification	English	Metric
Min Valve Stem Dia.		
Intake	.3095	7.861
Exhaust	.3080	7.823
Min Valve Face	.031	.794
Max Valve Guide Inside Dia.	.316	8.026

Valve condition is critical for proper engine performance. The valves should be inspected for both sealing, and wear.

Clean and inspect each valve face for distortion or corrosion. Check the valve stem for wear. (Illust. 7-13) Replace valve if stem diameter is less than: Intake **.3095 (7.861 mm)** Exhaust **.3080 (7.823 mm)**.



7-13

If the valves have been checked and are in a usable condition, the valve face should be ground at a 45 degree angle. If after grinding the valve face the top margin is less than **.03125 (.794 mm)**, the valve should be replaced. (Illust. 7-14)



7-14

The valves are not identical. Valves marked "EX" or "X" are installed in the exhaust valve location. Valves marked "I" are installed in the intake valve location. If the valves are unmarked, the smaller valve (head) is installed in the exhaust valve location.

VALVE GUIDES

The valve guides are not replaceable but should be checked for wear. Using a split ball gauge and a micrometer, measure the inside diameter of the valve guides. (Illust. 7-15) This measurement should not exceed **.316 (8.026 mm)** If a guide is found to be out of specification the cylinder head will need to be replaced as a complete assembly.



7-15

VALVE SPRINGS

Specification	English Std.	Metric
Valve Spring Free Length	1.935 - 1.995	49.15 - 50.67

The valve springs should be checked for both ends being parallel and the free length being **1.935/1.995 (49.15/50.67 mm)**. Replace the springs if less than the specification. (Illust. 7-16)

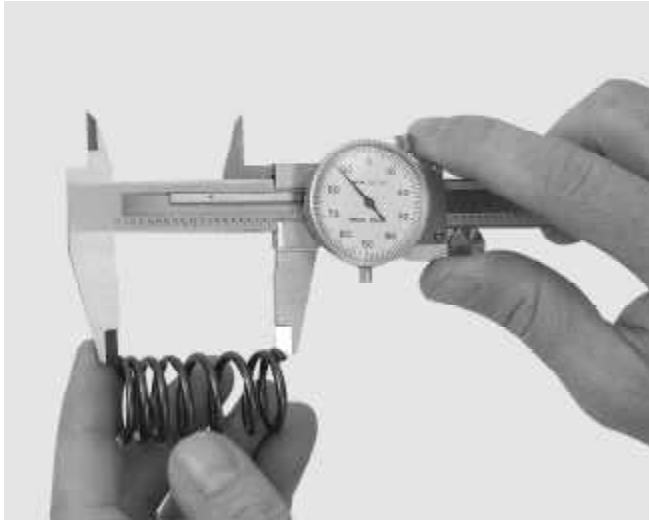

7-16

The valve springs are progressively wound. Meaning one end of the spring has the coils closer together. When installing the valve spring these coils must be opposite the cap and retainer. (Illust. 7-17)



7-17

PUSH RODS

The push rods should be checked for straightness and the ends for wear. If the push rod ends are worn or damaged, inspect the corresponding rocker arm socket or valve lifter for wear. Replace if necessary.

VALVE SEATS

Valve seats are not replaceable. If they are burned, pitted, or distorted they can be reconditioned using a grinding stone or a valve seat cutting tool. Valve seats are ground to a width of **3/64" (1.191 mm)** at 46 degrees.

The recommended procedure to properly cut a valve seat is to use the Neway Valve Cutting System, which consists of three different cutters.

First, use the 60 degree cutter to clean and narrow the seat from the bottom to the center. (Illust. 7-18)

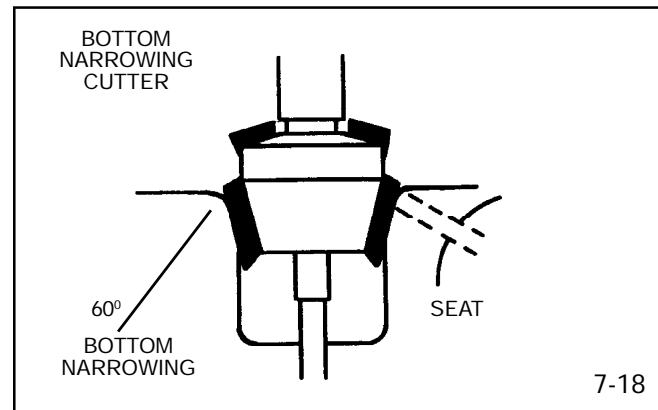

7-18

Second, use the 31 degree cutter to clean and narrow the seat from the top toward the center. (Illust. 7-19)

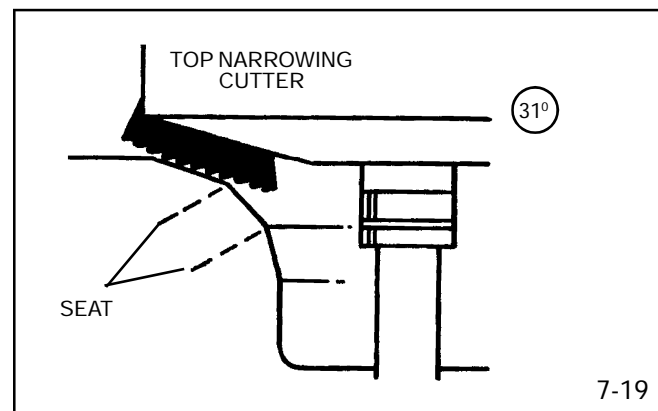

7-19

Third, use the 46 degree cutter to cut the seat to a width of **.078125 (1.191 mm)** (Illust. 7-20). Check the contact area of a new or reconditioned valve face on a finished valve seat. Cover the valve face with a black permanent marker. Insert the valve and turn back and forth in the seat about **1/8" (3mm)** with light pressure. A fine thin line should appear on the valve face. The contact area or line should be continuous on the upper 1/3 of the valve face.

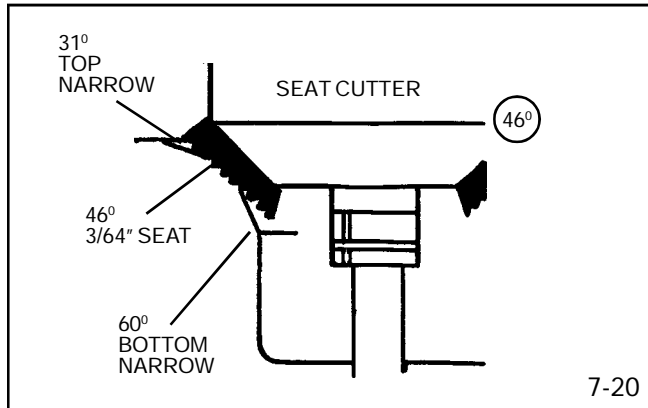

INTERNAL ENGINE COMPONENT INSPECTION

CYLINDERS

Visually check the cylinders for broken or cracked fins or a severely damaged cylinder bore. Check all bearing areas for wear or scoring.

Use a dial bore gauge or telescoping transfer gauge with a micrometer to accurately measure the cylinder bore condition. Measure the center of the piston travel area and approximately **1/2" to 3/4" (12.7 - 19.05 mm)** from the top and the bottom of each cylinder. Measure at 90 degrees to the piston pin, and even with the piston pin at each level. (Illust. 7-21)

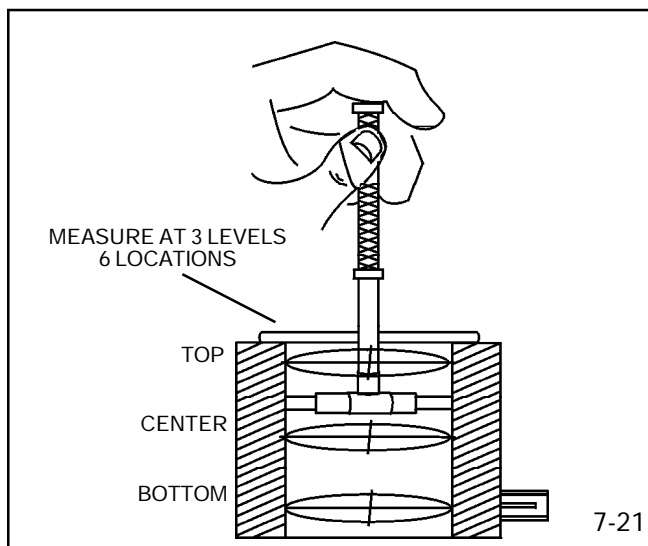

A rigid type hone is recommended to "true" any minor cylinder irregularities. If the cylinder bore is worn, scored or out of round more than **.005" (.127 mm)** oversize, it should be re-sized to **.010" or .020" (.254-.508 mm)** oversize. In some cases engines are built with oversize cylinders in manufacturing. If the cylinder is oversize, the oversize value will be imprinted in the top of the cylinder casting.

If you have determined the cylinders are within tolerance to hone, proceed as follows. Use a commercially available rigid hone of the proper size. Chuck the hone in a drill press with a spindle speed of approximately 600-RPM. Start with coarse stones and center the cylinder under the drill press spindle. Lower the hone so the lower end of the stone contacts the lowest point in the cylinder bore. Hone the cylinder using lubrication until you have full cylinder contact.

Change the stones to 380 grit for finish honing. Run the hone up and down the full length of the cylinder at approximately 50 strokes per minute. Every fourth or fifth stroke, move the hone far enough to extend the stones one inch beyond the top and bottom of the cylinder bore. At this rate you should achieve a crosshatch pattern between 35-45 degrees. (Illust. 7-22)

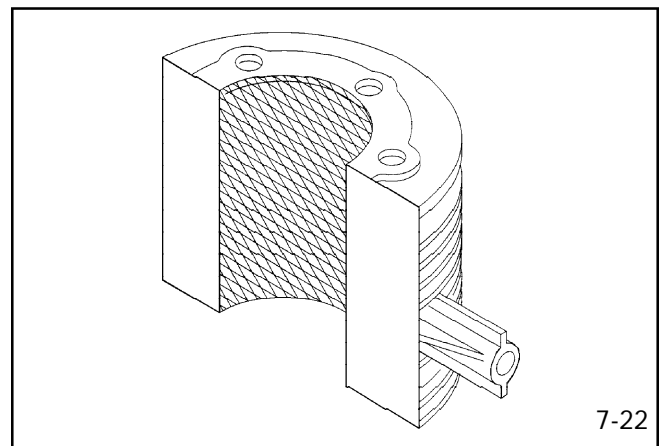

NOTE: Always use honing oil to lubricate and cool the stones. This will also help obtain the best finish.

If cylinder oversizing is needed we recommend boring the cylinders with a commercial boring bar. Many Authorized Service Dealers and machine shops offer this service. Before you choose this method we recommend costing out a short block replacement, which may be more cost effective.

Clean the cylinder and crankcase with warm, soapy water and a stiff brush. Rinse thoroughly with clean water, and dry. Continue the cleaning procedure until a clean white cloth wiped on any internal surface reveals no honing residue or dirt. Coat the cylinder bore lightly with oil.

Replace the piston and the piston rings with the correct oversize parts as indicated in the parts manual, microfiche or computer parts look-up systems.

PISTONS, RINGS, AND CONNECTING RODS

PISTON

Specification	English Std.	Metric
Piston Diameter	3.1220 3.1235	79.2988 79.3369
Pin (Piston) Diameter	.6248	15.870
Piston Pin Bore Diameter	.6251 .6257	15.878 15.893
Piston Ring Grooves Top and Center	.0645 .0665	1.638 1.689
Piston Ring Groove Bottom	.1255 .1275	3.189 3.239

Clean all carbon from the piston top and the ring grooves before measuring. Visually inspect the piston skirt area for scoring or scratches. If scoring or deep scratches are evident, replace the piston. The pistons should be checked for wear by measuring near the bottom of the skirt 90 degrees from the piston pinhole. (Illust. 7-23)

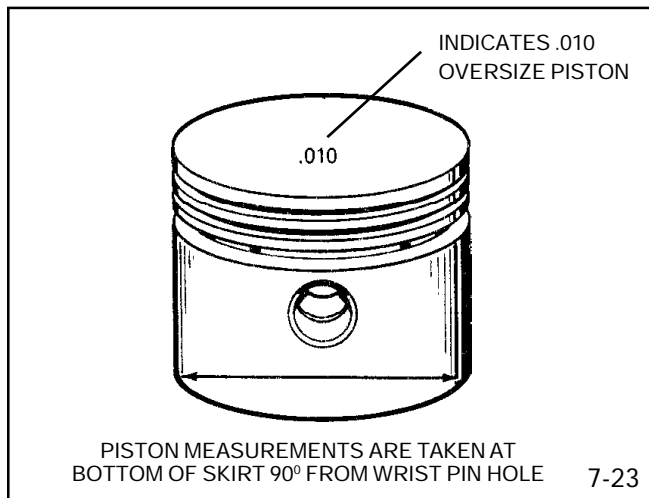

If the cylinder bore needs re-sizing, an oversize piston will be necessary. Oversize pistons are identified by the decimal oversize value imprinted on the top of the piston. (Illust. 7-24)



7-24

Check the piston ring, side clearance using a feeler gauge and a new ring. (Illust. 7-25)



7-25

RINGS

Specification	English Std.	Metric
Piston Ring Side Clearance	.002-.005 Top .001-.004 Center .001-.004 Bottom	.051-.127 Top .025-.102 Center .025-.102 Bottom
Piston Ring End Gap	.007-.015 Top .013-.021 Center .005-.013 Bottom	.178-.381-Top .330-.533 Center .127-.330 Bottom

After the cylinder bore diameter has been checked and is acceptable to rebuild, the ring end gap should be checked using new rings. Place a new compression ring squarely in the center of the ring travel area. Use the piston upside down without rings to push the ring down in the cylinder. (Illust. 7-26) Measure the gap with a feeler gauge. (Illust. 7-27) The ring end gap must be within specification to have adequate oil control.

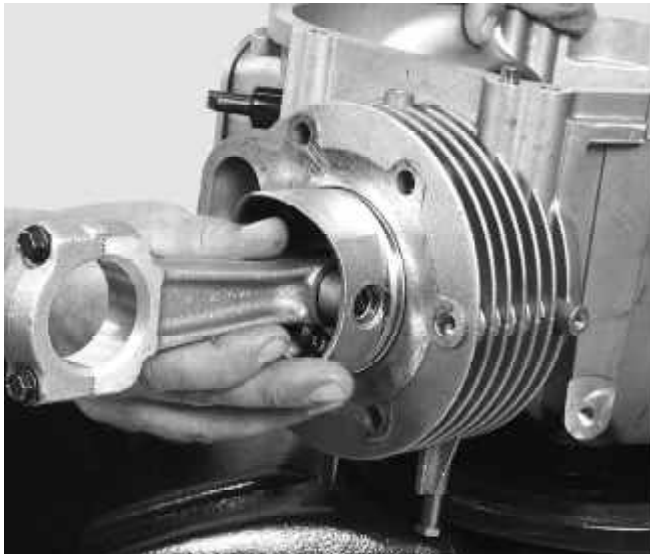

7-26



7-27

NOTES:

1. A difference exists in piston ring end gaps between the upper and center compression rings. Check the specification table for the appropriate ring end gap.
2. Use a ring expander (Tecumseh tool part number 670117) to replace the piston rings. Do not spread the rings too wide or breakage will result.
3. If installing new rings on a used piston, piston ring side clearance must be checked.
4. Always replace the rings in sets.
5. Always install the piston and ring assembly in the cylinder bore with the ring end gaps staggered.
6. When installing new rings in a used cylinder, the cylinder wall should be de-glazed using a commercially available de-glazing tool or hone with 380 grit stones. The crosshatch pattern should be 35-45 degree's.

The emission ring set used on the TVT consists of two compression rings and an oil control ring. The top compression ring is barrel faced on the outside. This ring can be installed with either side up. The second compression ring will have an outside notch, which must face down or towards the piston skirt. The oil control ring can be installed with either side up. (Illust. 7-28)

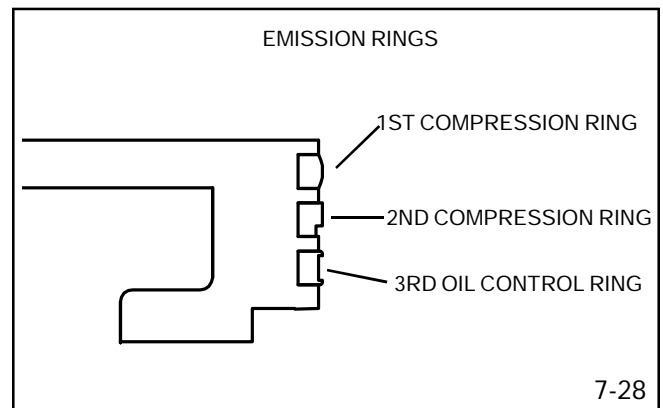

7-28

CONNECTING RODS

Specifications	English Std.	Metric
Connecting Rod Journal Diameter	1.6223 1.6228	41.206 41.219
Connecting rod Diameter Piston Pin End	.6251 .6256	15.878 15.890
Connecting Rod Thrust Face	.988 .996	25.095 25.299
Connecting Rod Thrust Clearance With Both Rods On Crankshaft	.006 .027	.1510 .6858

The TVT engine is designed with offset piston pins (not centered). This aids to centralize the combustion force on the piston. When installing the connecting rod to the piston it is critical that the rod be installed correctly.

1. Locate the marking (ARROW) on the side of the piston assembly. (Illust. 7-29)

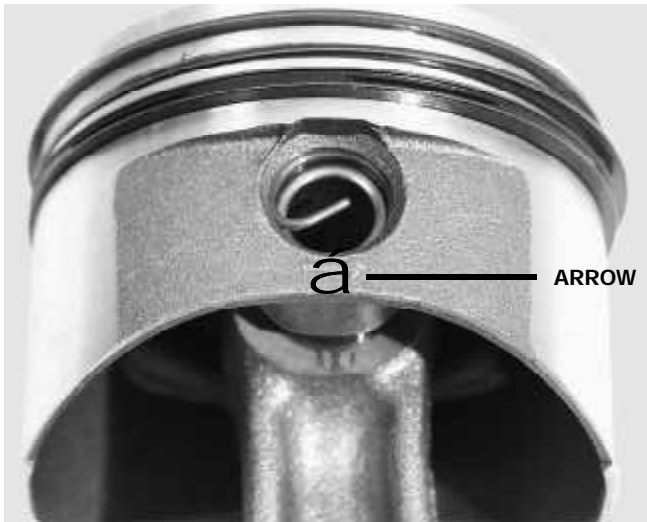

7-29

2. Locate the match marks on the connecting rod assembly. (Illust. 7-30)

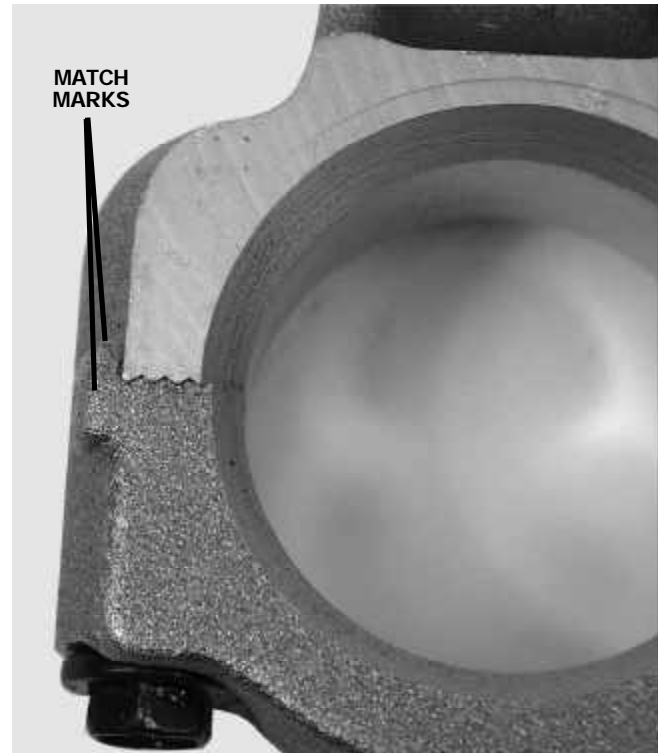

7-30

- Position the connecting rod match marks and the arrow on the piston assembly to be on the same side, and assemble. (Illust. 7-31)

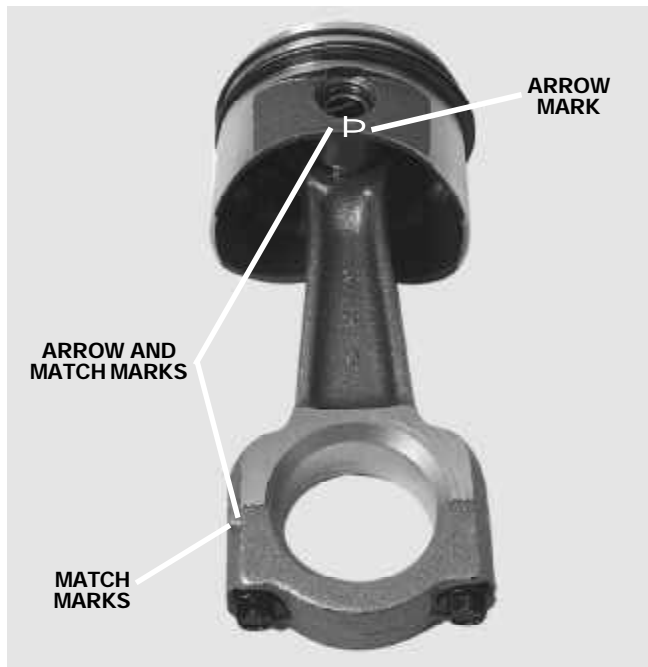

7-31

- When installing the piston and rod assembly in the engine the match marks must align and face out.

CRANKSHAFTS AND CAMSHAFTS

Inspect the crankshaft visually and with a micrometer for wear, scratching, scoring, or out of round condition at the bearing surfaces. Check for bends on the PTO end using a straight edge, square or a dial indicator.

Specifications	English Std.	Metric
Crankshaft end play	.0053 - .025	.1364 - .6350
Crankshaft connecting rod journal thrust width	1.998 2.003	50.749 50.876
Connecting rod bearing diameter crankshaft end	1.6234 1.6240	41.235 41.249
Main bearing journal dia. Flywheel and PTO end	1.6245 1.6250	41.263 41.275

CAUTION: NEVER ATTEMPT TO STRAIGHTEN A BENT CRANKSHAFT.

Inspect the crankshaft oil galley for blockage or obstruction. (Illust. 7-32)



7-32

CAMSHAFTS

Check the camshaft bearing surfaces for wear using a micrometer. Inspect the cam lobes for scoring or excessive wear.

Specifications	English Std.	Metric
Camshaft Bearing Diameter	.6235	15.836
	.6240	15.849
Cylinder and Flange Camshaft Bearing Diameter	.6245	15.862
	.6255	15.887

MECHANICAL COMPRESSION RELEASE

The Mechanical Compression Release (MCR) incorporates pins located in the camshaft. The pins extend above the exhaust cam lobes, lifting the valve and relieving engine compression for easier starting. When the engine starts, centrifugal force moves the weight outward and the pin will drop back down. The engine will now run at full compression.

The components of the MCR except for the internal pins are serviceable. When servicing the MCR be cautious not to misplace the pins, as a new camshaft would be necessary.

Clean the camshaft with solvent and dry all parts with compressed air. Make sure that the pins, weight and shaft of the mechanical compression release are operating freely and smoothly. (Illust. 7-33)



7-33

VALVE LIFTERS

Visually check the lifter for wear on the cam contact surface, the cylinder contact surface and push rod contact surface. If any damage is noted replace the lifters. (Illust. 7-34).



7-34

CRANKCASE BREATHER

The crankcase breather is located on the number one (lowest) cylinder side. It consists of a cover, cover gasket, breather element, reed valve and a limiter plate. The breather cavity may be cleaned with solvent. Inspect the reed plate for sealing. If an **.003" (.076 mm)** air gap exists between the reed plate and the cylinder boss, the reed plate must be replaced. When installing the reed plate the notched corner must face the cylinder head side of the engine. (Illust. 7-35) The cover plate mounts onto the cylinder with the outside lip facing out.

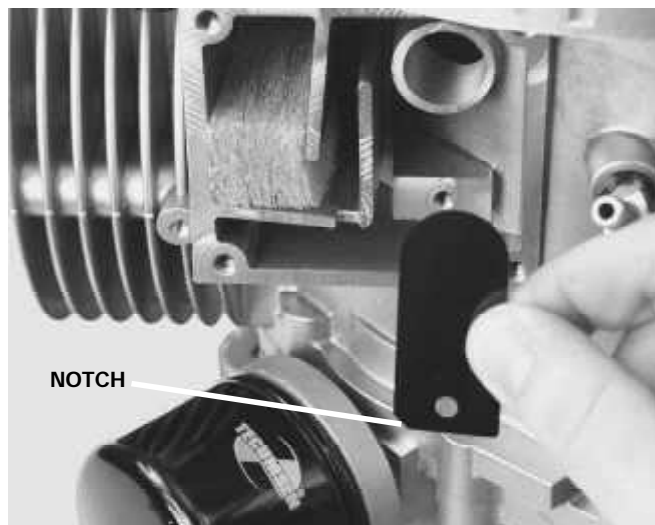

7-35

CYLINDER COVER

Specification	English Std.	Metric
Main Bearing Diameter	$\frac{1.625}{1.627}$	41.313
Cylinder and PTO	1.627	41.325

Clean and inspect the cover, looking for wear and scoring of the bearing surfaces. Measure the bearing surface diameters using a telescoping gauge and check the specifications for worn or damaged parts. Replace as necessary.

When reinstalling the cover, apply a drop of Loctite 242 to the cover screw threads and torque the cover screws to **250 inch lbs. (28 Nm)**. Always install a new gasket once the seating surface has been broken.

CHAPTER 8. ENGINE ASSEMBLY

ENGINE ASSEMBLY

The following procedures apply to most engine specs. Actual procedure may vary.

1. Use new gaskets and seals at all locations. Clean all internal engine parts with solvent and blow dry with compressed air or allow to air dry.
2. Apply engine oil to the crankshaft bearing surfaces. Using seal protector **670330**, insert the tapered end of the crankshaft into the crankcase. Slide the crankshaft in until it bottoms.
3. Assemble the piston and rod together. **The connecting rod match marks must be facing the same side as the arrow on the side of the pistons.**
4. Apply engine oil to the piston skirt, rings, connecting rod bearing surface, and the cylinder bore. Having installed and staggered piston ring end gaps, use a band type ring compressor to compress the rings, and push the piston assembly into the cylinder (Illust. 8-1). **The match marks on the connecting rod(s) and the arrow on the side of piston(s) must be facing out of the crankcase.** Push the piston assembly(s) in until the rod is positioned on the crankshaft rod journal surface.



8-1

5. Align the match marks on the rod cap and rod. Install the rod cap bolts and tighten the bolts in equal increments to **210 inch lbs. (24Nm)**.

NOTE: If reinstalling a connecting rod assembly, the original rod and cap must be assembled together. Do Not Interchange.

6. Assemble the compression release components to the camshaft. Install spring end "A" through the weight from the shaft side. Wrap spring end "B" over the rivet head as shown (Illust. 8-2).

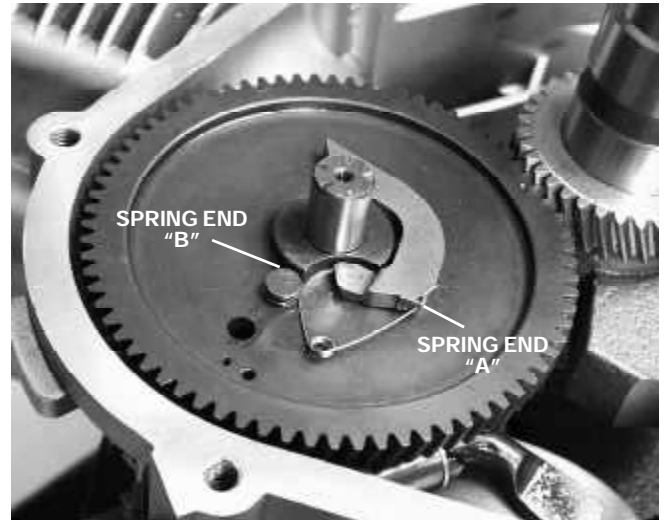

8-2

7. Pre-lube and install the lifters and camshaft. Align the timing mark or notched tooth on the crankshaft gear to the mark or hole in the camshaft gear. (Illust. 8-3)



8-3

8. Install the oil pump shaft into the flange cover from the bottom up. The long end of the shaft inserts into the cover. (Illust. 8-4)



8-4

9. Slide on the oil pump gear so as the raised center portion is on top. (Illust. 8-5) Fasten the gear down with the retaining ring.



8-5

10. Use seal protector 670330 to install the mounting flange with the governor gear assembly installed to the crankcase. Use the dowel pins to position the flange and new gasket. Slightly rotate the crankshaft to allow the governor gear to mesh. Do not force. Apply a drop of blue Loctite 242 to the cover screw threads and torque to **250 in. lbs. (28 Nm)**.

11. Apply a small amount of engine oil and install the oil pump rotor. Install a new "O" ring and the pump cover. Tighten the screws to **60 inch pounds (6.8 Nm)** torque.

12. Install the breather reed with the notched corner facing the cylinder head. Install the limiter plate, breather cover and a new gasket. The breather cover must have the outer lip facing out.

13. Rotate the crankshaft to place the piston in the #1 cylinder at Top Dead Center (TDC) on the compression stroke. (Cylinder nearest mounting flange).

14. Pre-assemble the valve and spring assemblies on the cylinder heads. Place the springs (dampening coils toward the head) over the valve guides. Install the valve caps on the springs with the larger opening away from the springs. Use spring compressor tool part 670315A to compress the spring and cap and install the retainers.

15. Install the cylinder head using a new head gasket. Torque the head bolts in **60 in. lbs. (6.7 Nm)** increments following the numbered sequence. (Illust. 8-6) Cylinder head bolt torque specification **230 in. lbs. (26 Nm)**.

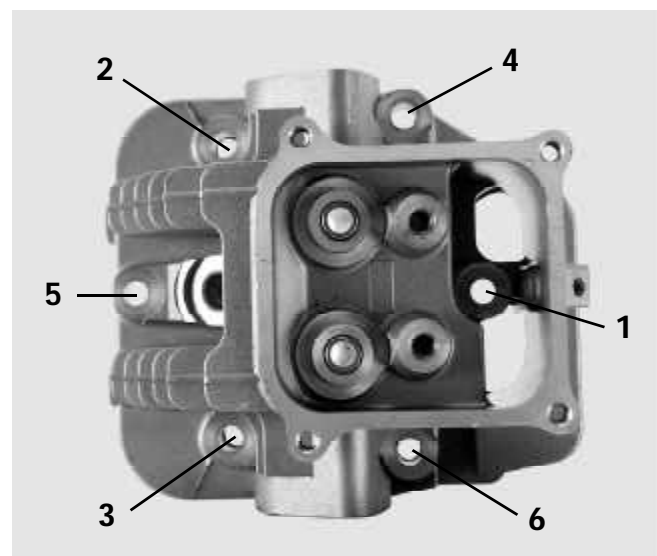

8-6

16. Insert the push rods in the lifter sockets with the longer steel end towards the rocker arms. Install the rocker arms (socket end toward the push rod) and guide plate (with the arms facing up) onto the cylinder head. Thread the rocker arm stud on until excessive play is removed. (Illust. 8-7)



8-7

17. Set the valve lash with the engine cold, the piston at T.D.C. compression stroke and both valves closed. Insert a **.004" (.102mm)** feeler gauge between the rocker arm and valve stem. Adjust until a slight sliding drag is felt. Hold the rocker arm stud using a **7/16" (11.1125 mm)** wrench or socket while using a **1/2" (12.7 mm)** crowfoot to tighten the lock nut to **120 in. lbs. (13.5 Nm)** of torque. Rotate the crankshaft at least one full turn to check push rod movement and valve lash. Repeat for other cylinder head assembly.
18. Install the rocker arm cover(s) using a new gasket. Torque the cover screws to **80 in. lbs. (9 Nm)**.
19. Attach the governor arm lever if removed.
20. Attach the alternator coil and route the wires away from the flywheel area.
21. Install the flywheel key, flywheel, flywheel fan, fan retainer, flat washer, lock washer, and flywheel nut. Use strap wrench part #670305 to hold the flywheel and torque to **700 in. lbs. (79 Nm)**.
22. Install the ignition mounting studs and torque to **40 in. lbs. (7 Nm)** Mount the ignition modules, use a **.0125" (.3175 mm)** air gap tool (part # 670297) between the flywheel magnets and the laminations of the module. Torque the mounting screws to 45-in. lbs. and remove the tool. Check for contact while rotating the flywheel. Attach the ignition groundout lead to the module terminal.

23. Install the intake pipe, carburetors and governor linkage. Check the governor and speed control hook-up and adjustment - see Chapter 4 Governors and Linkage.

24. Attach the wiring harness to the fuel shut-off solenoids.

25. Synchronize the carburetors. See Chapter 4 Governors and Linkage.

26. Install remaining engine shroud pieces. Blower housing, cylinder head covers and air filter assembly.

27. Attach the fuel line and secure with clamps.

NOTE: Replace the fuel filter.

28. Install a new oil filter and fill the engine with oil to the full mark on the dipstick. Add fresh fuel to the fuel tank and secure the cap.

29. Install the spark plug and high-tension lead. Mount the engine to the equipment and connect wiring and control cables.

30. Start the engine and allow it to run approximately five minutes to reach operating temperature. Verify the idle and high speed R.P.M settings.

CHAPTER 9. TROUBLESHOOTING & TESTING

ENGINE KNOCKS

1. Check the crankshaft coupler or pulley for loose fit, loose bolts or crankshaft key damage. Remove, inspect, and replace as necessary. Re-install and re-torque the bolts to the proper specifications of the OEM.
2. Check the flywheel key and keyways for wear or partial shearing. Replace any damaged components. Tighten the flywheel nut to the proper torque.
3. Check for the correct air gap at the ignition modules. An improper setting may cause contact between the flywheel and laminations.
4. Remove the cylinder heads and check for excessive carbon in the combustion chamber. Also check that the head gasket fit is correct laying it over the cylinder **not the head**. Check the spark plugs for proper reach and heat range.
5. Check for proper valve lash.
6. Check internal components (pistons, cylinder bore, connecting rods and crankshaft) for wear or damage.

ENGINE OVERHEATS

Before checking any of the following remove and inspect the spark plugs one at a time. By reading the color of each plug you can quickly narrow down which cylinder is causing the problem. Spark plug color evaluation charts can usually be found in spark plug manufacturer books.

1. Make sure the engine is not being overloaded. Remove excessive loads by limiting operation speed, processing less material.
2. Check the oil level and viscosity. Add or replace as necessary.
3. Check for clogged cooling fins or obstructions to the airflow. Remove the blower housing and clean the cooling fins.
4. Check the carburetor for restricted metering jets, causing a lean fuel delivery. Remove and clean the carburetor using tag wire and compressed air. See **Chapter 3** under "Service."
5. Check the engine R.P.M. setting using a vibra tach or other tachometer. Compare it to the R.P.M. settings found on microfiche card #30 or the computer Parts Look Up system.
6. Check the ignition system. Check the CDI module air gap and flywheel key condition.

7. Remove the cylinder head to check for excessive carbon buildup or a leaking head gasket(s). Replace head gasket(s).
8. Check for the correct spark plug and heat range. Consult the parts look-up systems for the correct plug.

SURGES OR RUNS UNEVENLY

1. Check the fuel cap for proper venting. Loosen the cap and retry engine operation.
2. Replace or clean the air filter(s).
3. Static Test the Governor system.
4. Visually check all linkages. Check the governor shaft, throttle link or link connector bushings for wear or binding. For adjustment see **Chapter 4**.
5. Check the condition of the carburetor jets and passages. Service as outlined in **Chapter 3**.
6. Verify engine R.P.M. setting using a vibra tach or other tachometer. Compare it to the R.P.M. settings found on microfiche card # 30. Adjust as necessary.
7. Check the ignition system operation using a gap type tester installed between the high-tension lead and spark plug. Check for intermittent spark.

ENGINE MISFIRES

1. Check the spark plugs for the proper reach and heat range. Diagnose their condition. Replace if questionable.
2. Replace the fuel and fuel filter if the condition is in question. Set up a remote fuel tank to supply known good fuel on a temporary basis. Test engine performance.

NOTE: Questionable fuel should always be disposed of properly. Contact your local governing body regarding disposal options in your area.

3. Temporarily isolate the engine ground wires from safety system. Check the ignition system with an in-line ignition tester.
4. Check for carbon buildup in the combustion chamber.
5. Check valve lash. Inspect the valves and valve seats for leakage. Check for scoring or discoloration on the valve stem in the valve guides area. Recondition the valves and seats if questionable.

ENGINE VIBRATES EXCESSIVELY

1. Detach and ground the high-tension leads from the spark plugs. Check the PTO end of the crankshaft for bends. Use a straight edge, square or a dial indicator.
2. Check the engine mounting hardware for proper torque. Check the platform for rigidity.
3. Isolate the engine, remove and check any attached equipment for an out of balance condition. Start and run the engine without anything attached.

BREATHER PASSING OIL

1. Check the oil level. Ensure the engine is not overfilled. Verify the viscosity rating of the oil being used is to specification.
2. Check the angle of operation. Avoid prolonged use at severe angles.
3. Check for excessive engine R.P.M. Use a vibra-tach or other tachometer to adjust to the specified R.P.M. setting found on microfiche card # 30 or the computer Parts Look Up system.
4. Check the crankcase for leaking or damaged gaskets, seals, or "O"-rings. External leaks may not be evident; however, an atmospheric pressure leak may prevent the engine from achieving a crankcase vacuum. Check the crankcase vacuum using a water manometer or vacuum gauge.
5. Check the breather cover, cover gasket and reed for damage, or improper installation.
6. Check cylinder compression. If the engine has weak compression, determine the cause (worn rings, leaking head gasket, or leaking valves). A cylinder leak down tester can be used to further evaluate the problem cylinder(s).

NOTE: Follow the tool manufacturer's procedures to prevent further engine damage.

EXCESSIVE OIL CONSUMPTION

1. Check the oil level, oil viscosity, and oil condition. Drain and fill to the proper level.
2. Check the angle of operation. Avoid prolonged use at a severe angle.
3. Check for leaking or damaged gaskets, seals, or "O"-rings. External leaks may not be evident; however, a leak may prevent the engine from achieving a crankcase vacuum.

4. Check for excessive engine R.P.M. Use a vibra-tach or other tachometer to adjust to the specified R.P.M. setting found on microfiche card # 30 or the computer Parts Look Up system.
5. Check the breather cover, cover gasket and reed for damage or improper installation.
6. Clean the cooling fins to prevent overheating.
7. Check the carburetor for a lean running condition caused by restricted fuel passages.
8. Check the cylinder compression. If the engine has weak compression, determine the cause (worn rings, leaking head gasket, or leaking valves). A cylinder leak-down tester can be used to further evaluate the problem cylinder(s).

NOTE: Follow the tool manufactures procedures to prevent further engine damage.

9. Check the valve guides for excessive wear.
10. Check the intake valve stem seal for wear or damage.

LACKS POWER

1. Check the air intake for an obstruction (plugged, dirty or oil-saturated air filter).
2. Check the oil level, oil viscosity, and oil condition. Replace and fill to the proper level.
3. Diagnose each of the spark plugs condition.
4. Check the carburetor(s) for improper choke plate engagement, or a restricted fuel passage(s).
5. Check the exhaust port for a restriction preventing proper exhaust flow. Thoroughly inspect the muffler for loose baffles or an obstruction.
6. Check the engine valve lash. Reset the valves at the proper clearance.
7. Check the valves for proper seating and valve guide clearance. Recondition the valves and seats. Replace the valves if necessary.
8. Check the ignition system operation. Use a gap type spark tester installed between the high-tension lead and the spark plug. Check the flywheel key for partial shearing and the CDI module air gap.

CHAPTER 10. ENGINE SPECIFICATIONS

TVT 691 ENGINE SPECIFICATIONS

	English Std.	Metric
Displacement	42.18 cubic inches	691cc
Stroke	2.75	69.85
Bore	3.126 3.125	79.4004 79.375
PISTONS		
Piston Diameter	3.1220 3.1235	79.2988 79.3369
Piston Pin Diameter	.6248	15.870
Piston Pin Bore Diameter	.6251 .6257	15.878 15.893
Piston , Top and Middle Ring Grooves	.0645 .0665	1.638 1.689
Piston, Lower Ring Groove	.1255 .1275	3.188 3.239
Piston Ring Side Clearance	.002 - .005 Top .001 - .004 Center .001 - .004 Bottom	.0890 .0640 .0640
Piston Ring End Gaps	.007-.015 – Top .013-.021 – Center .005 -.013 – Bottom	.178-.381 .330-.533 .127-.330
VALVES		
Valve lash	Both .004	Both .102
Valve Seat Angle - Cylinder Head	Both 46 Degrees	Both 46 Degrees
Valve Seat Width - Cylinder Head	Both .042 .052	Both 1.067 1.321
Valve Face Angle	Both 45 Degrees	Both 45 Degrees
Valve Stem Diameter Exhaust	.3080 .3085	7.823 7.836
Valve Stem Diameter Intake	.3095 .310	7.861 7.874
Standard Valve Guide Dia.	.312 .313	7.925 7.950
Valve Spring Free Length	1.935 1.995	49.15 50.67

TVT 691 ENGINE SPECIFICATIONS (CONTINUED)

	English Std.	Metric
CRANKSHAFT		
Crankshaft End Play	.0053 .025	.1346 .6350
Crankshaft Connecting Rod Journal Thrust Width	1.998 2.003	50.749 50.876
Crankshaft Connecting Rod Journal Diameter	1.6223 1.6228	41.206 41.219
Main Bearing Journal Dia. Flywheel and PTO End	1.6245 1.625	41.263 41.275
CONNECTING ROD		
Connecting Rod Bearing Dia. Crankshaft End	1.6234 1.624	41.235 41.249
Connecting Rod Dia. Pin End	.6251 .6256	15.878 15.890
Connecting Rod Thrust Face	.988 .996	25.095 25.299
Connecting Rod Thrust Clearance With Both Rods on Crank	.006 .027	.1510 .6860
CYLINDER		
Main Bearing Diameter Cylinder and Flange	1.6265 1.627	41.3131 41.3258
Camshaft Bearing Diameter Block and Sump	.6245 .6255	15.8623 15.8877
Camshaft Bearing Journal Diameter	.6235 .624	15.8369 15.8496

TORQUE SPECIFICATIONS

Torque specifications below 10-ft lbs. will be listed in inch lbs. only to encourage the use of a inch lbs. torque wrench.

	In. lbs.	Ft. lbs.	Nm
Cylinder Head Bolts	230	19	26
Connecting Rod Bolts	210	17.5	24
Cylinder Cover (sump)	250	21	28
Flywheel Nut	700	58	79
Spark Plug	250	21	28
Ignition Module to Stud	45	—	5
Ignition Module Stud to Block	40		5
Intake Manifold to Head	120	10	14
Carburetor Studs to Manifold	60		7
Air Cleaner Body to Carburetor	42		5
Air Cleaner Body Screw to Cylinder	82		9
Oil Fill Tube to Blower Housing	82		9
Blower Housing to Cylinder	82		9
Deflector to Air Cleaner Body	32		4
Governor Lever Clamp Screw	95		11
Oil Pump Cover Screw	60		7
Oil Filter Adapter to Cylinder	105		12
Throttle Control Lever to Manifold (shoulder bolt)	42		5
Rocker Arm Jam Nut	120	10	14
Rocker Arm Cover Mounting Screw	52		6
Breather Cover Screws	52		6

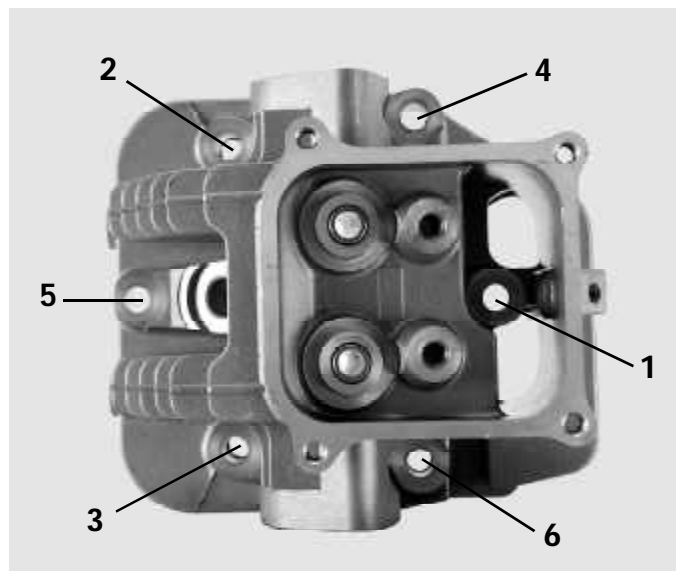

Service Tool List

Special Service, Diagnostic, Measurement & Repair Tools	
Description	Part Number
Tachometer (Inductive or Vibratach)	670156 Vibratach or 670365 Inductive
Ignition Tester	670366
Multi Meter VOM & Temperature	670349
Compression Tester	670358
Outside Micrometers 0-1"	670350
Outside Micrometers 1-2:	670351
Outside Micrometers 2-3"	670352
Outside Micrometers 3-4:	670353
Telescoping Gauge Set	670357
Dial Indicator	670241
Inspection Plate (Plate Glass)	Obtain Locally
Feeler Gauge Set	670361
Inch Pound Torque Wrench 0-600 inch lbs.	670363
Valve Spring Compressor "C" Type	670362
Piston Ring Compressor	670359
Piston Ring Expander	670117
**Valve Seat (Neway LG3000 Kit or comparable)	670347
**Face Cutting Set (Neway 612 Gizmatic)	670348
Cylinder Hone (Flex)	670360

Special Service, Diagnostic, Measurement & Repair Tools	
Description	Part Number
Starter Bendix Ring Tool	670346
Crankcase Vacuum / Oil pressure adapter	670364
Hole Gauge Set	670356
Oil Vacuum System (110 Volt)	670354
Extreme Duty Oil Tank	670367
Leak Test Kit - Complete	670340
Leak Test Transaxle/Carburetor Adapter Kit	670345
Dial Caliper, 6"	670368
Air Gap Gauge	670297
Spark Plug Gap Gauge	670256
Oil Seal Remover	670331
Oil Seal Protector/Installer	670330
Oil Seal Driver	670272
Flywheel Knockoff Tool	670329
Flywheel Strap Wrench	670305
Torx 8	670334
Torx 10	670333
Torx 15	670323
Torx 20	670324
Torx 25	670319
Torx 30	670320
Torx E-5 Socket	670339
Torx E-6 Socket	670257
Torx E-8 Socket	670307

* See Tecumseh Form #694862 for Complete Tool Kit List

** Neway LG2000 or 102 kits can be upgraded by calling
Neway direct: 1-800-248-3889