

TECUMSEH

TECHNICIAN'S HANDBOOK

This manual covers the following models:
TVS, TVXL, HXL, HSK 840 - 850

Other illustrated Tecumseh 2-Cycle Engine, 4-Cycle Engine
and Transmission manuals; booklets; and wall charts are
available through Tecumseh.

For complete listing write or call

HSK/HXL840 - 850 TVS/TVXL840 2-Cycle Engines



TABLE OF CONTENTS

	Page
ENGINE IDENTIFICATION AND CARE	
IDENTIFICATION	1
INTERPRETATION OF MODEL NUMBER	1
FUELS	1
ENGINE OIL	1
FUEL/OIL MIX	1
STORAGE	2
TUNE-UP PROCEDURE	2
EXHAUST PORT CLEANING	2
AIR CLEANER	
AIR CLEANER	3
POLYURETHANE-TYPE AIR CLEANER	3
PAPER TYPE AIR CLEANER	3
KLEEN-AIRE® CANISTER STYLE DUEL STAGE AIR CLEANER	3
2 CYCLE THEORY OF OPERATION	
OPERATION OF HSK, HXL840-850 MODELS	4
OPERATION OF TVS, TVXL840	4
TERMS	4
EXHAUST OR SCAVENGE PHASE	4
PORTS	4
LUBRICATION	4
REED VALVE	4
CARBURETION	
CARBURETOR IDENTIFICATION	5
SERIES I OPERATION	5
SERIES VI OPERATION	5 - 6
SERVICING THE CARBURETOR - SERIES VI	
REBUILDING THE CARBURETOR	7 - 8
TROUBLESHOOTING CARBURETION SERIES VI	
TABLE OF PROBLEMS AND CORRECTIONS	9
SERVICING THE CARBURETOR - SERIES I	
SERVICE	10
SERVICE CARBURETOR PRE-SETS AND ADJUSTMENTS	
PRE-SETS AND ADJUSTMENTS	11
FINAL ADJUSTMENTS	11
TROUBLESHOOTING CARBURETION SERIES I	
TABLE OF PROBLEMS AND CORRECTIONS	12
PISTON AND RINGS	
840 - 850 MODELS	13
E.G.R. TUBE - SERVICE AND INSTALLATION (TVS/TVXL 840 ONLY)	
PORT PLUG REINSTALLATION	14
ANTI-PUDDLING METER HOLE SCREEN	
REPLACEMENT OF SCREEN	15
SELF-ENERGIZING BRAKE SYSTEM	
DISASSEMBLY OF THE BRAKE SYSTEM	16
REASSEMBLY OF THE BRAKE SYSTEM	16 - 17
GOVERNOR LINKAGE AND ADJUSTMENT	
LINKAGE LOCATION	18
GOVERNOR ADJUSTMENT	18
GOVERNOR FOLLOWER ARM AND SHAFT ASSEMBLY	18
GOVERNOR LINKAGE AND ADJUSTMENT - HXL/HSK840 - 850	
CONTROLS	19
REWIND STARTER	
TYPE I	20
TYPE II	20
840 - 850 DISASSEMBLY	
MODEL 840-850 DISASSEMBLY	21
EXHAUST PORT CLEANING	22 - 25
TVS & TVXL 840 REASSEMBLY	
840 HORIZONTAL AND VERTICAL REASSEMBLY	26 - 30
TORQUE SPECIFICATIONS	
TORQUE LIMITS FOR REASSEMBLY	31
ENGINE SPECIFICATIONS	
TOLERANCES IN THE ENGINES	32
TRAINING AIDS AND TOOLS	
LISTING OF SPECIAL TRAINING AIDS AND TOOLS	33 - 34

ENGINE IDENTIFICATION AND CARE

IDENTIFICATION

Tecumseh engine Models 840 - 850, specification, and serial number or date of manufacture (D.O.M.) are stamped into the blower housing, or located on a decal on the engine in locations as shown.

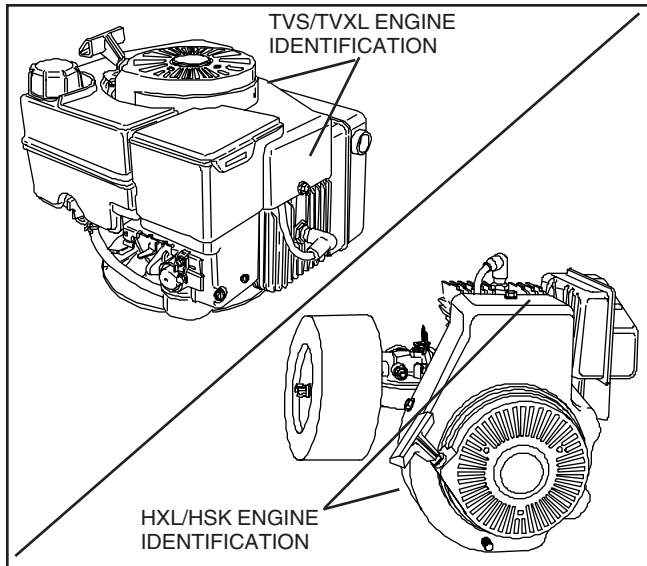

Interpretation of Model Number

The letter designations in a model number indicate the basic type of engine. This is followed by the specification number and date of manufacture.

- HXL - Horizontal Extra Life
- HSK - Horizontal Snow King®
- TVS - Tecumseh Vertical Style

840/850 - Base engine model

SPECIFICATION NUMBER

Specification number used to locate correct parts.

5215C is the serial number or D.O.M. (Date of Manufacture)

5 is the last digit in the year of manufacture (1995).

215 indicates the calendar day of that year (215th day or August 3, 1995).

C represents the line and shift on which the engine was built at the factory.

FUELS. Tecumseh Products Company strongly recommends the use of fresh, clean, UNLEADED regular gasoline in all Tecumseh Engines. Unleaded gasoline burns cleaner, extends engine life and promotes good starting by reducing the build up of carbon deposits. Premium gas or gasohol containing no more than 10% ethanol can be used if unleaded fuel is not available.

NOTE: NEVER USE GASOLINE CONTAINING METHANOL, GASOHOL CONTAINING MORE THAN 10% ETHANOL, UNLEADED REGULAR GASOLINE CONTAINING MORE THAN 15% M.T.B.E. OR ETBE, GASOLINE ADDITIVES, OR WHITE GAS BECAUSE ENGINE/FUEL SYSTEM DAMAGE COULD RESULT.

NOTE: In countries where unleaded gasoline is not available, regular gas can be used.

Make sure that gasoline and oil are stored in clean, covered, rust free containers. Dirt in fuel can clog small ports and passages in the carburetor. Use fresh gasoline only. Gasoline standing for long periods of time develop a gum that will result in fouled spark plugs, clogged fuel lines, carburetors and fuel screens. Using fuel that is not fresh will cause engines to be hard starting, especially in cold temperatures.

Clean gas cap, tank and fuel container spout when filling fuel tank, to assure that dirt will not get into fuel system.

If gasohol is used, special care is required when the engine is to be stored for extended periods.

ENGINE OIL. Use Clean, high quality **2 CYCLE OIL. NMMA TC-WII, or TC-W3.**

FUEL/OIL MIX. Follow fuel and engine oil requirements listed in the Owner's Manual. Disregard conflicting instructions found on oil containers. The fuel/oil mix for all 840-850's is 50:1.

NOTE: Sears Craftsman models use a 40:1 mix which is acceptable.

NOTE: ALWAYS DOUBLE THE AMOUNT OF OIL FOR THE FIRST GALLON OF MIX FOR ENGINE BREAK IN.

To assure thorough mixing of oil and gasoline, fill container with gasoline to one quarter full, add oil as recommended, shake container vigorously and then add remainder of gasoline. **Do not mix directly in engine or equipment fuel tank.**

Some models will have a Mix-Rite cup attached to the under side of the air cleaner cover to assure proper fuel/oil mixture.

The mixing chart below should be used for proper fuel and oil mix ratio.

FUEL MIX CHART		Mixture 50:1	
U.S.		S.I. (METRIC)	
Gas	Oil To Be Added	Petrol	Oil To Be Added
1 Gal.	2-1/2 oz.	4 Liters	80 ml
2 Gal.	5 oz.	8 Liters	160 ml
5 Gal.	13 oz.	20 Liters	400 ml

NOTE: Beginning with the 1998 Snowblower season, Horizontal Snow King® engines will have Emission Compliance information on the identification decal.

IMPORTANT ENGINE INFORMATION

TECUMSEH PRODUCTS CO.

FUEL: REGULAR UNLEADED
FUEL/OIL MIX 50:1

ENGINE MODEL TVXL840 8405F (E)

ENGINE FAMILY

DISPLACEMENT D.O.M. 5018B

CAUTION FOR PERSONAL PROTECTION REFER TO OWNER'S MANUAL FOR IMPORTANT SAFETY AND MAINTENANCE INFORMATION

STORAGE:

NEVER STORE ENGINE WITH FUEL IN TANK INDOORS OR IN ENCLOSED, POORLY VENTILATED ENCLOSURES WHERE FUEL FUMES MAY REACH AN OPEN FLAME, SPARK OR PILOT LIGHT AS ON A FURNACE, WATER HEATER, CLOTHES DRYER, ETC.

If engine is to be stored over 30 days, prepare for storage as follows:

1. Remove all gasoline from fuel tank to prevent gum deposits from forming in tank and other fuel system components, causing possible malfunction of the engine.

DRAIN FUEL INTO APPROVED CONTAINER OUTDOORS, AWAY FROM OPEN FLAMES.

Run engine until fuel tank is empty and engine stops due to lack of fuel.

Fuel stabilizer (such as STA-BIL) is an acceptable alternative in minimizing the formation of fuel gum deposits during storage. Add stabilizer to fuel in fuel tank or storage container. Always follow mix ratio found on stabilizer container. Run engine at least 10 minutes after adding stabilizer to allow it to reach carburetor.

If gasohol has been used, complete preceding instructions and then add a small amount, one pint or less, of unleaded regular automotive gasoline properly mixed with the specified lubricating oil and run the engine until the fuel tank is empty and the engine stops due to lack of fuel.

2. Pull starter handle slowly until resistance is felt due to compression pressure, then stop. Release starter tension slowly to prevent engine from reversing due to compression pressure. This position will close both the intake and exhaust ports to prevent corrosion of the piston and the cylinder bore.
3. Clean unit by removing any dirt from exterior of the engine and equipment.

TUNE-UP PROCEDURE. The following is a minor tune-up procedure. Repair procedures for this engine and its components are listed in this manual if the engine does not perform to satisfaction after tune-up is performed.

CAUTION: Remove spark plug wire before doing any service work on engine.

1. Service or replace air cleaner as necessary.

NOTE: Snow King® engines do not use an air filter due to the clean operating environment and to prevent filter freeze-up.

2. Remove blower housing, clean all dirt, grass or debris from air intake screen, cylinder cooling fins, and carburetor governor levers and linkage.
3. Remove carburetor, clean and install a carburetor kit, make adjustment presets where needed. Presets are found in the carburetor section of this manual.

Make sure fuel tank, fuel filters and fuel lines are clean. Reinstall carburetor, replacing any worn or damaged governor springs or linkage. Make proper governor adjustment. Adjustments are found in the manual under governor linkage and adjustment and engine reassembly.

4. Replace with correct spark plug.
5. Make sure all ignition wires are properly routed, so they will not rub on flywheel. Inspect all ignition wires for abrasion or damage. Remove flywheel and check flywheel key, reinstall flywheel, torque flywheel nut to specifications. Set air gap between solid state module and flywheel at .0125". Air gap gauge, part no. 670297 may be used.
6. The engine must be firmly mounted to the associated equipment. On rotary lawnmowers, make sure blade is properly balanced and correctly torqued. See disassembly section for flywheel removal and air gap setting procedure.
7. Make sure all remote linkage is properly adjusted for proper operation.
8. Fill tank with proper fuel/oil mix.
9. Run the engine, allow it to warm up 5 minutes, then adjust carburetor and set R.P.M. according to Tecumseh's recommendations.

Snow King® engines should be run in outdoor temperatures for engine adjustments.

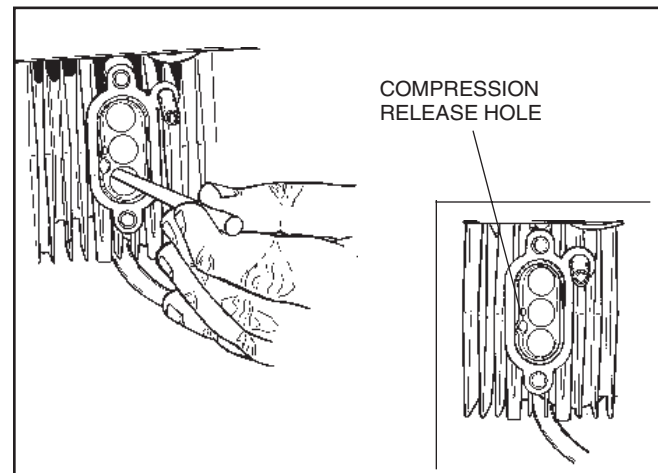

EXHAUST PORT CLEANING. The exhaust ports should be cleaned after each seventy-five (75) to one hundred (100) hours of use.

Before cleaning the ports place the piston in the Bottom Dead Center position. Then clean the ports using a pointed 3/8" diameter wooden dowel or similar tool. Be sure not to scratch the port area. Also remember to remove all the loose carbon particles from the engine.

AIR CLEANER

AIR CLEANER. Service the air cleaner frequently to prevent clogging of the element & screen and to prevent dust and dirt from entering the engine. Dust by-passing an improper or damaged air filter can quickly damage an engine. Always make certain covers and air cleaner connections are tightly sealed to prevent entry of dirt.

NOTE: SNOW KING MODELS DO NOT HAVE AIR FILTERS DUE TO THE CLEAN ENVIRONMENT THEY OPERATE IN AND TO PREVENT AIR CLEANER FREEZE UP.

If a loss of power occurs, inspect the air filter for clogging before making any adjustments.

NOTE: Use factory recommended parts only.

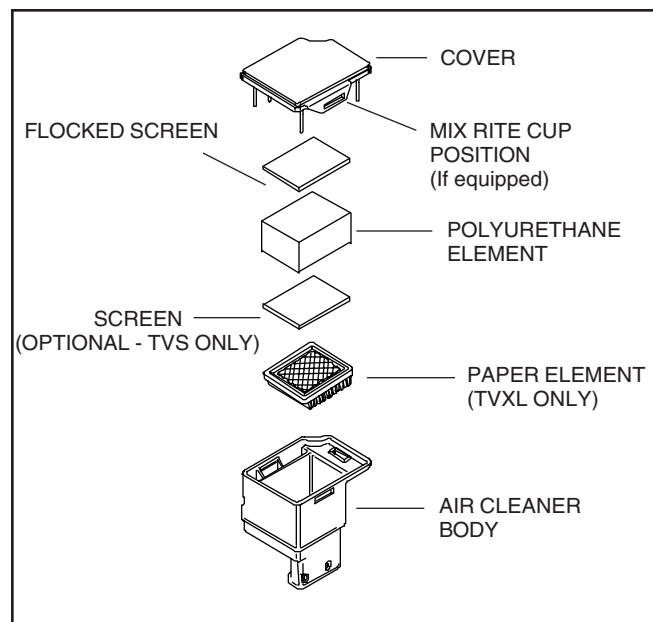

POLYURETHANE-TYPE AIR CLEANER. This serviceable air cleaner utilizes a polyurethane element which will clog with use. The element should be cleaned and serviced in the following manner.

Wash element in a detergent and water solution and squeeze (don't twist) until all dirt is removed. Rinse thoroughly.

Wrap in clean cloth and squeeze (don't twist) until completely dry.

Clean air cleaner body and cover. Dry thoroughly.

Re-oil element by applying generous quantity of engine oil to all sides. Squeeze vigorously to distribute oil and to remove excess oil.

When reassembling polyurethane type air cleaners, replace in the same order as pictured above.

Flocked screen elements may be cleaned by blowing compressed air through the screen from the back side. If screen can not be cleaned with this procedure, it should be replaced with a new screen.

NOTE: Polyurethane type filters will lose effectiveness if stored for extended periods of time, due to oil migration out of the filter. Re-oil filter as necessary.

PAPER TYPE AIR CLEANER. The paper type air cleaners found on some HXL, TVS and TVXL840-850's should be replaced once a year or more often in extremely dirty or dusty conditions.

DO NOT ATTEMPT TO CLEAN OR OIL PAPER FILTER'S.

NEVER RUN THE ENGINE WITHOUT THE COMPLETE AIR CLEANER INSTALLED ON THE ENGINE IF SO EQUIPPED.

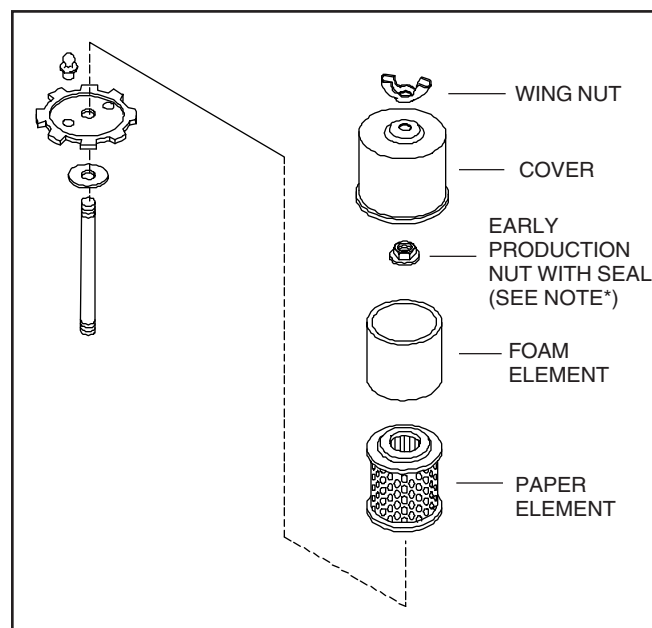

KLEEN-AIRE® CANISTER STYLE DUAL STAGE AIR CLEANER. This air cleaner consists of a paper type element with a polyurethane pre-cleaner around it. For servicing the assembly see instructions under Paper Type Air Cleaner and Polyurethane Type Air Cleaner.

Be sure to clean base and cover thoroughly before installing new paper filter.

NOTE: When installing a new foam pre-cleaner always turn it inside out before installing around the paper element to prevent gaps between paper element and pre-cleaner.

***NOTE*:** Tecumseh has changed the canister filter cartridge to remove the nut/seal assembly. If you receive a new filter with a rubber seal that is tight around the stud, follow the instruction sheet included regarding NOT RE-USING THE NUT.

2 CYCLE THEORY OF OPERATION

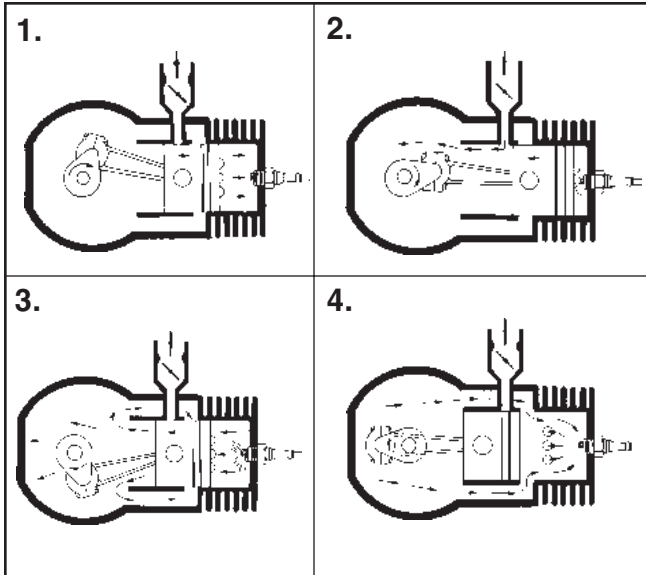

OPERATION OF HSK, HXL840-850 MODELS.

A low pressure area is created in the crankcase as the piston moves upward to compress the air / fuel mixture in the cylinder. Then the piston moves far enough to uncover the intake port, the air / fuel mixture from the carburetor flows into the engine crankcase due to higher pressure atmospheric air. Just before the piston reaches top dead center (TDC), the spark plug ignites the air / fuel mixture in the cylinder.

The expanding combustion gases force the piston down. The downward piston travel causes a pressure buildup in the crankcase. The piston uncovers the exhaust port first followed by the transfer ports. The exhaust flows out the exhaust port while the pressurized air / fuel mixture enters the cylinder from the crankcase through the transfer ports. As the piston travels upward the sequence is repeated.

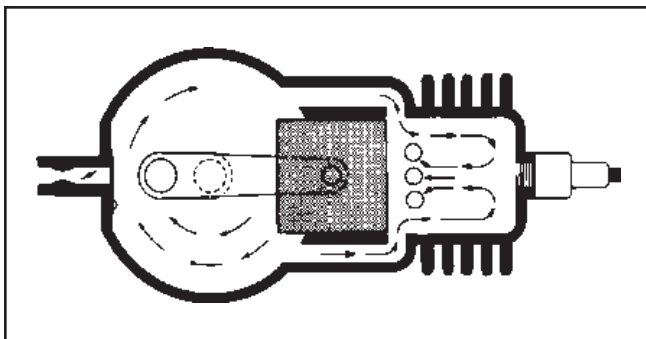

OPERATION OF TVS, TVXL840

This model uses a loop scavenge system with a reed valve.

The following illustrates the loop scavenge design which uses a vacuum-pressure activated reed valve. Here the ports are located on three sides of the cylinder; the intake ports are on two sides opposite each other, and the exhaust ports are illustrated by the three holes just above the head of the piston.

As the mixture flows into the combustion chamber through the transfer ports, it collides and is directed to the top of the combustion chamber looping when it strikes the cylinder head, thus forcing all spent gases out through the open exhaust ports.

TERMS. Listed are common terms often referred to on 2-cycle engines.

EXHAUST or SCAVENGE PHASE. The burned gases must be cleared out of the combustion chamber and replaced by a fresh charge of fuel-air mixture through the intake ports. The exhaust passes out through the exhaust ports into the outside air.

PORTS. Openings in the cylinder allow gases to pass into and out of the combustion chamber. The ports are opened or closed by the upward and downward movement of the piston.

EXHAUST PORTS. Allow the burned gases to pass out of the combustion chamber.

THIRD PORT (Sometimes called piston port). A third port is for entry of the fuel-air and oil mixture to the crankcase. From the crankcase the fuel-air mixture enters the combustion chamber through the intake ports. The third port is controlled by the piston skirt.

LUBRICATION. Tecumseh 2-cycle engines are lubricated by a gas oil mix. The correct mix ratio of oil and gas combines with air in the venturi and enters the crankcase. During engine operation the oil clings to all the internal moving parts for lubrication.

NOTE: ALWAYS MIX AT OUR RECOMMENDED RATIO AND USE ONLY CERTIFIED OILS OR WARRANTY IS VOID.

REED VALVE. A reed valve is activated by crankcase pressure or vacuum. A decrease in crankcase pressure opens the valve allowing the fuel air and oil mixture to enter the crankcase. Increased crankcase pressure closes the valve, preventing escape of the fuel-air and oil mixture back through the carburetor.

CARBURETION

CARBURETOR IDENTIFICATION

Tecumseh carburetors are identified by a model number and code date stamped on the carburetor as illustrated.

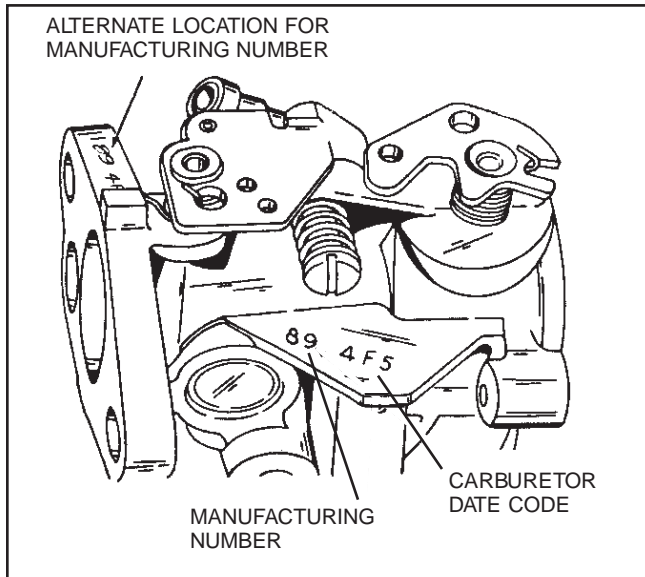

When servicing carburetors the model and date code number of the carburetor will be found on the carburetor body. It is a recommended procedure to use the engine model and specification number for looking up repair parts. However, if they are not available, the carburetor model number may be used for the proper carburetor repair parts. Cross reference the carburetor model number into a service part number using the Master Parts Manual or Microfiche and look up the required parts.

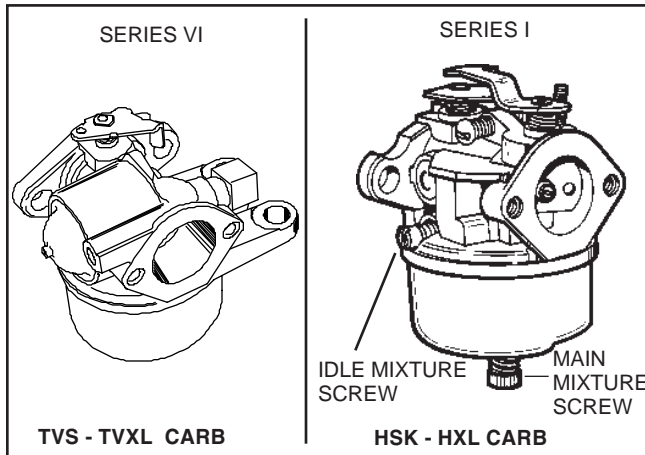

The TVS or TVXL840 engines use a Series VI carburetor. The Series VI has a fixed high speed and a fixed idle system.

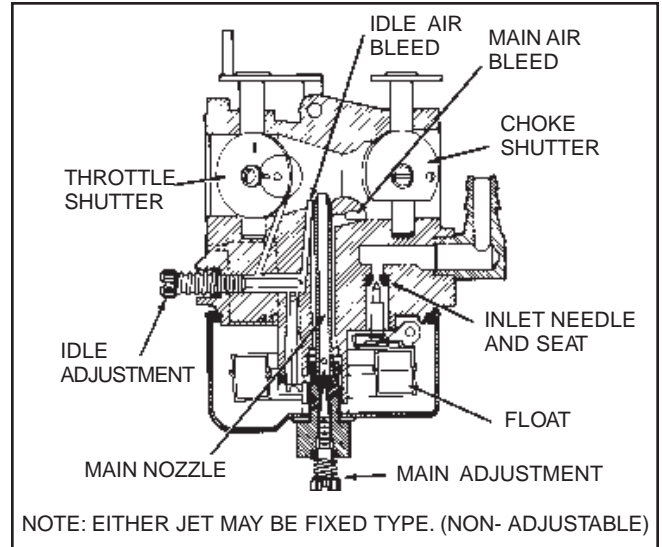

SERIES I OPERATION. The HSK and HXL840-850 models use a Series (I) carburetor. (Fixed speed models have no idle circuit with a fixed main jet.)

Variable speed engines use a full circuit Series I which has an idle fuel circuit (as shown above).

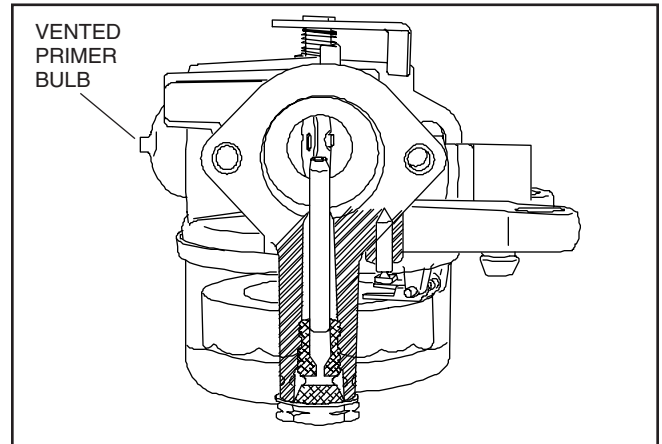

SERIES VI OPERATION. This carburetor is a high bred of the dual system carburetor. It is equipped with a primer for easy starting and has a fixed main and idle circuit. Fuel fills the prime well in the bowl nut to the level maintained by the float. Pushing the primer button 3-5 times will provide the rich mixture required to start a cold engine. It takes about 3 seconds for the prime well to refill after each prime.

If the engine is used under cool weather conditions, the number of primes should be increased.

NOTE: All Emissionized engines will be equipped with fixed jet carburetors.

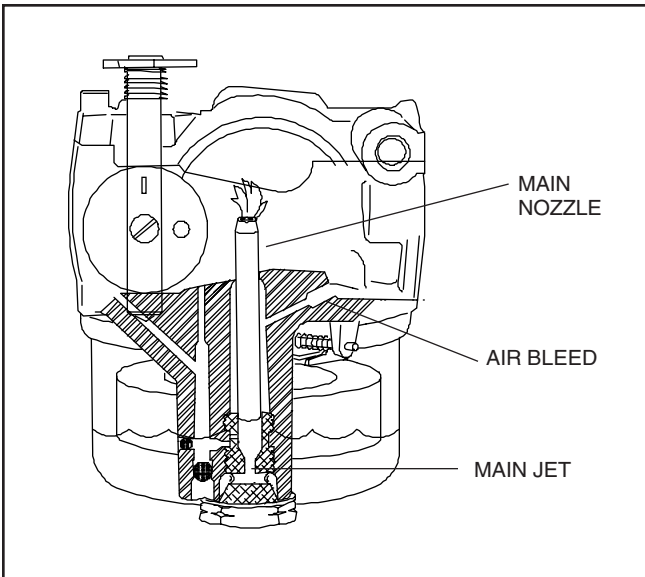

When the engine starts and runs, the fuel level in the bowl and prime well stabilizes, then air from the air bleed and fuel from the main jet is pulled up the main nozzle for engine operation.

CAUTION: Do not exceed equipment manufacturers recommended RPM. Excessive RPM will cause the carburetor fuel mixture to lean out and the engine may overheat and eventually fail.

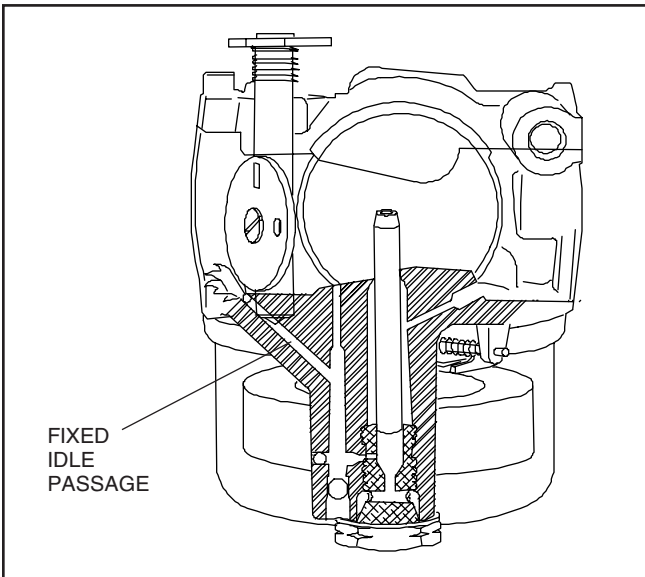

At Idle or Low Load running, the fuel will be drawn up the fixed idle passage in the carb.

SERVICING THE CARBURETOR - SERIES VI

To service the Series VI carburetor follow the procedure listed in this section of the manual.

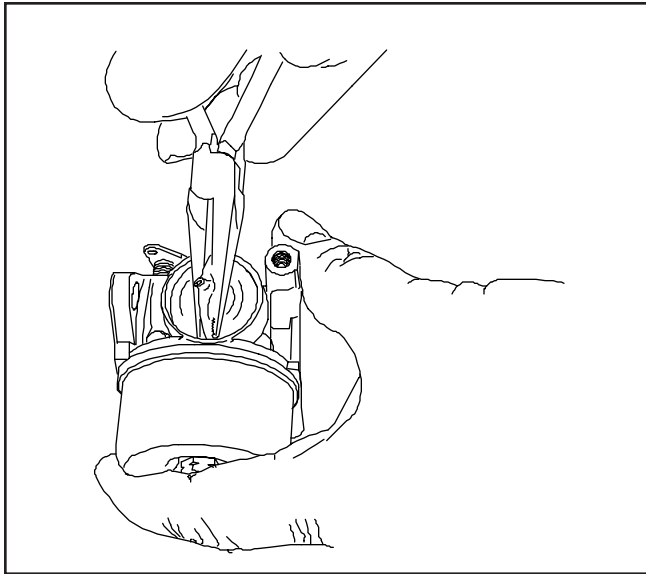

After the carburetor has been removed from the engine, remove the primer bulb. Using a needle nose pliers, grasp the primer bulb and roll the primer bulb out.

CAUTION: Wear safety glasses or goggles while removing the retaining ring that holds the primer bulb in place.

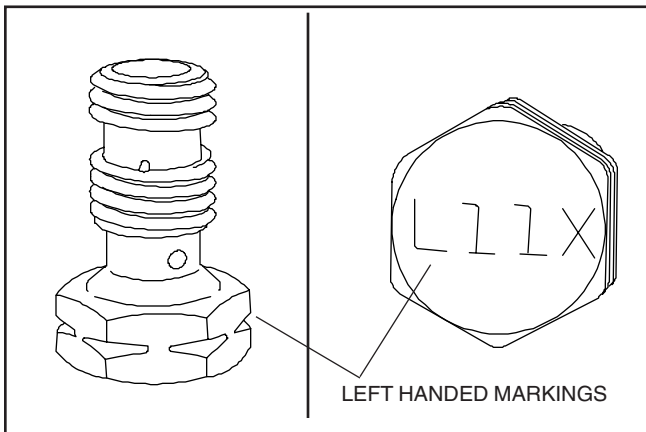

NOTE: Left handed fixed jets are used on TVS/TVXL840 models only.

Remove the bowl nut. The bowl nut on this carburetor has LEFT HANDED threads. This can be identified by the letter "L" preceding the numbering on the bowl nut. Also, the head of the bowl nut is notched. This is the same identification used in many industries for left handed nuts.

If the bowl nut is turned the wrong way, it will break off in the center leg where the fuel pick up passages are drilled. If this happens, a screwdriver will fit into the bowl nut which then may be turned out in the proper direction.

Remove the throttle plate and shaft with the dust seal and spring.

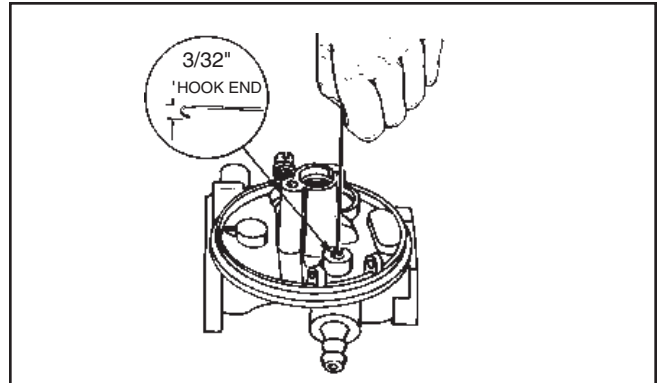

Remove the inlet seat using a hook made from a paper clip or a No. 4 crochet hook.

Soak the carburetor body and bowl nut in a commercial cleaner no longer than 30 minutes. It is not necessary to remove the fuel fitting when soaking the carburetor.

All passages may be probed with soft tag wire and blown out with compressed air to open plugged or restricted passages.

REBUILDING THE CARBURETOR

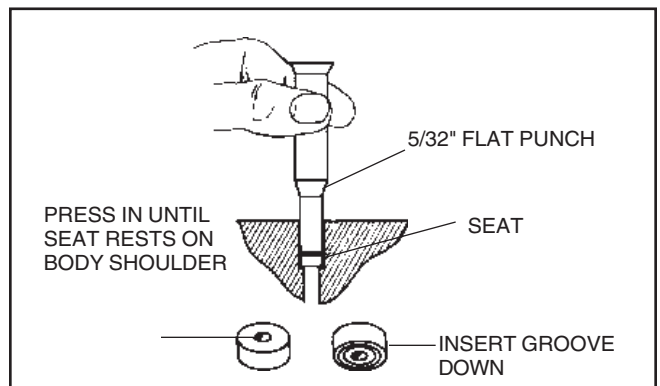

Replace the seat into the carburetor body. The side of the seat with the groove in, goes into the carburetor body so that the smooth side can be seen. Place a small drop of oil onto the seat and press it in with a flat punch or a point plunger until it seats. Be careful not to scratch the polished inlet bore.

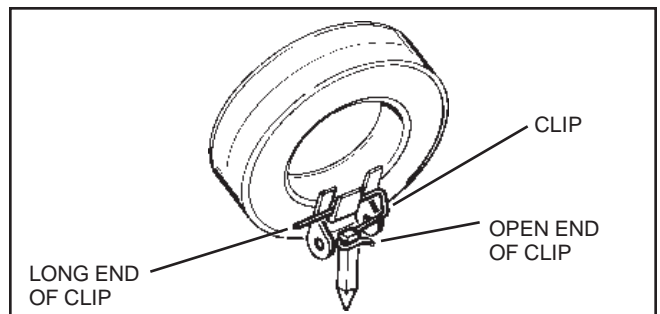

Place the inlet needle and spring clip onto the float and set in place. The long end of the spring clip must point towards the air cleaner end of the carburetor. This will ensure that the inlet needle will drop and raise in a straight line.

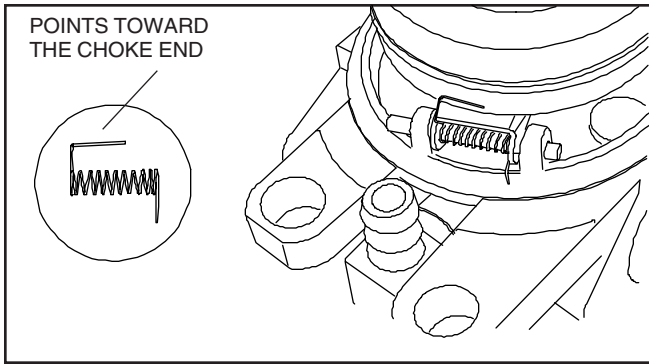

This carburetor uses a dampening spring on the float. The short leg hooks onto the carburetor body and the longer end points towards the choke end.

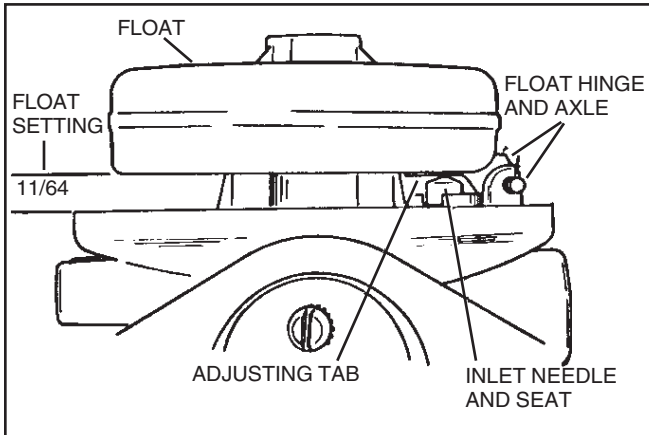

All Tecumseh carburetors with an adjustable float require the correct float height to achieve the proper operation and easy engine starts. To check the float setting, hold the carburetor in an upside down position. Remove the bowl nut, float bowl, and "O" ring. Place an 11/64" diameter drill bit across the top of the carburetor casting on the opposite side and parallel to the float hinge pin. The float must just touch the drill bit when the bit is flush with the edge of the float. If the float is too high or too low, adjust the height by bending the tab accordingly. If the required adjustment is minor, the tab adjustment may be made without removing the float and carefully inserting a small bladed screwdriver to bend the tab.

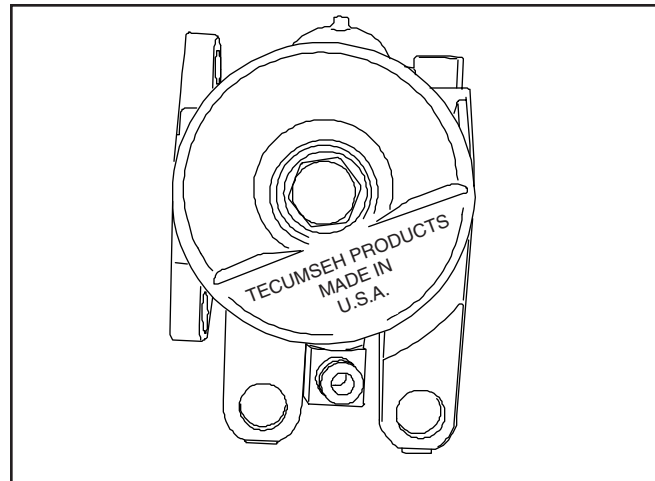

Install a new bowl "O" ring. Place the bowl onto the carburetor with the flat area of the bowl over the hinge pin and running parallel to the hinge pin. Insert the bowl nut with the fiber washer between the bowl and the nut. Remember this is a left handed bowl nut.

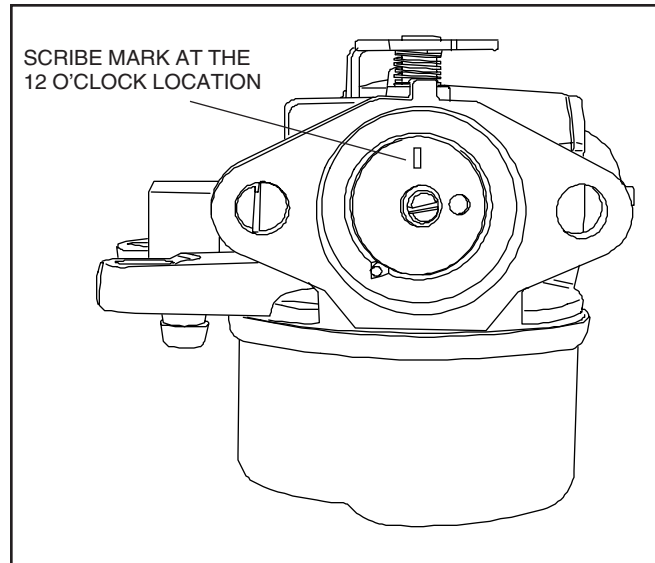

Install the throttle shaft and shutter. The scribe mark on the shutter is in the twelve o'clock position. Any other position may cause the throttle to stick. Use a new throttle shutter screw to insure that the screw does not come loose during running. A new dust seal should also be used on the throttle shaft.

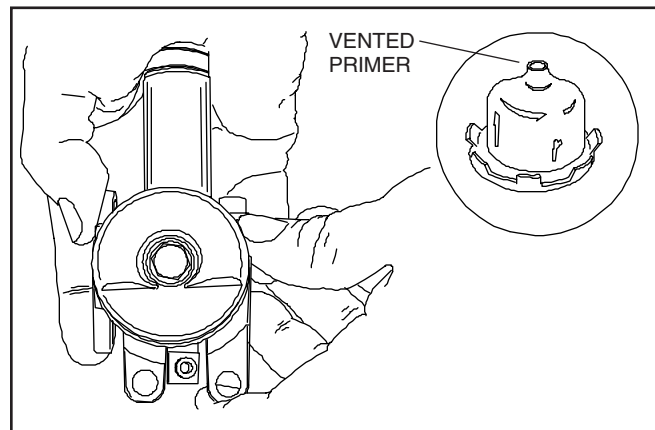

Place the primer bulb with the retainer ring into a 3/4" deep reach socket. Press down until seated. NOTE: An improper seat will cause poor priming.

TROUBLESHOOTING CARBURETION SERIES VI

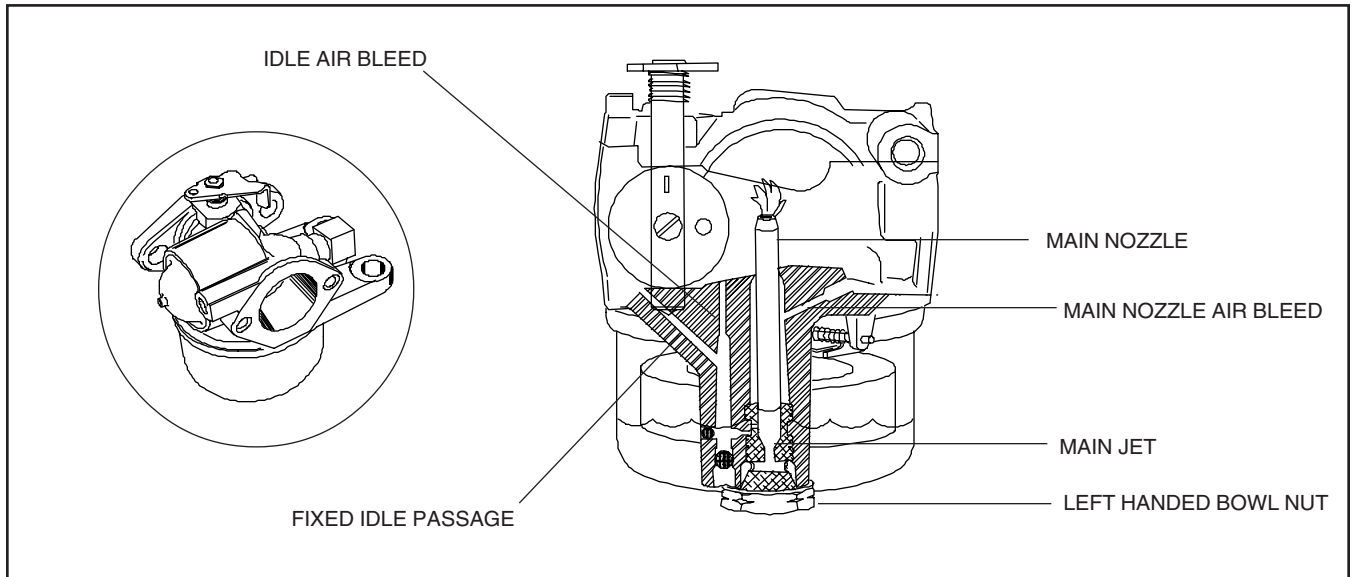

TROUBLE	CORRECTIONS
Carburetor out of adjustment	3, 4, 11, 15
Engine will not start	1, 2, 3, 4, 5, 8, 10, 11, 13, 16, 18, 19
Engine will not accelerate	2, 3, 4, 5, 8, 11, 15, 18
Engine hunts (at idle or high speed)	3, 4, 8, 9, 10, 11, 15, 16, 18
Engine will not idle	3, 4, 8, 9, 10, 11, 14, 15, 16, 18
Engine lacks power at high speed	2, 3, 4, 7, 8, 11, 15, 16, 18, 19
Carburetor floods	4, 7, 13, 16, 17, 18
Carburetor leaks	4, 6, 7, 13, 14, 18
Engine overspeeds	8, 9, 10, 11, 14, 15
Idle speed is excessive	8, 9, 10, 11, 14, 15
Engine starves for fuel at high speed (leans out)	1, 3, 4, 5, 11, 12, 13, 14, 16
Performance unsatisfactory after being serviced	ALL

- | | |
|--|---|
| <ol style="list-style-type: none"> 1. Fill tank with fuel. 2. Check ignition, spark plug and compression. 3. Clean air cleaner service as required. 4. Dirt or restriction in fuel system clean tank and fuel strainers, and filter, check for kinks or sharp bends. 5. Check for stale fuel or water in fuel fill with fresh fuel/oil mixture of correct ratio. 6. Examine fuel line and pick-up for sealing at fittings. 7. Check and clean atmospheric vent holes. 8. Examine throttle shaft for binding or excessive play -remove all dirt or paint, replace shaft. 9. Examine throttle return spring for operation. 10. Check position of throttle plate. | <ol style="list-style-type: none"> 11. Adjust control cable or linkage to assure carburetor control. 12. Clean carburetor after removing all metallic parts that are serviceable. Trace all passages. 13. Check inlet needle and seat for condition and proper installation. 14. Check sealing of gaskets and O rings. 15. Adjust governor linkage. 16. Adjust float setting. 17. Check float shaft for wear and float for leaks or dents. 18. Is carburetor operating on excessive angle? 19. Check primer bulb for damage. |
|--|---|

SERVICING THE CARBURETOR SERIES I

The following covers variations from the Series VI carburetors.

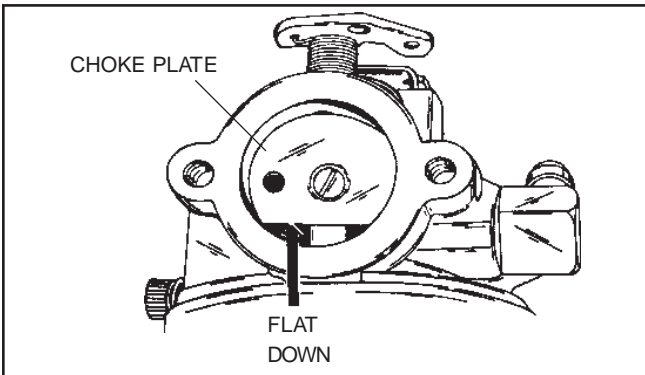

The Series (I) carburetor is used on summer and winter versions of the horizontal 840 thru 850 Series, and is equipped with a choke to be positioned as shown.

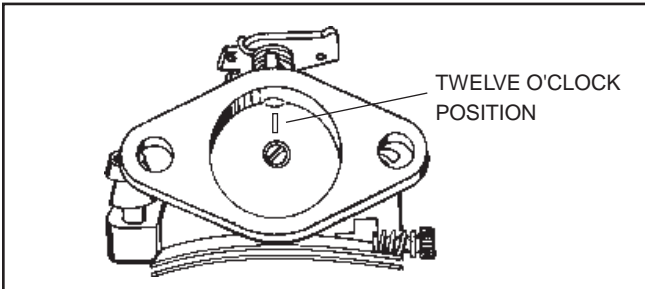

The throttle plate on the Series (I) is set in place at the 12 o'clock position. ALWAYS USE SERVICE SCREWS IF YOU HAVE REMOVED EITHER THE CHOKE OR THROTTLE SHUTTER. TECUMSEH SCREWS ARE EQUIPPED WITH DRY LOCTITE ADHESIVE.

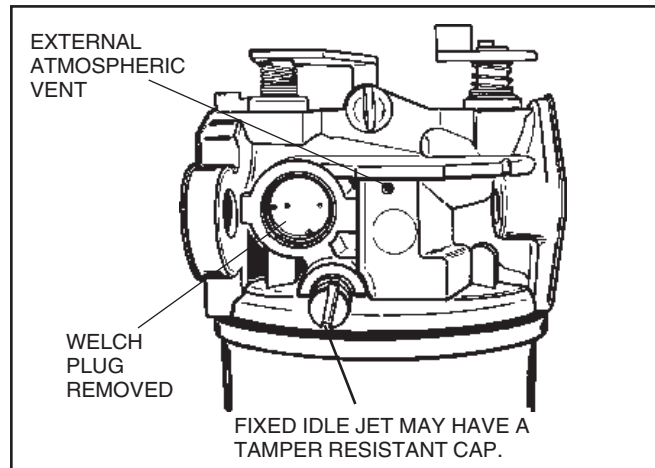
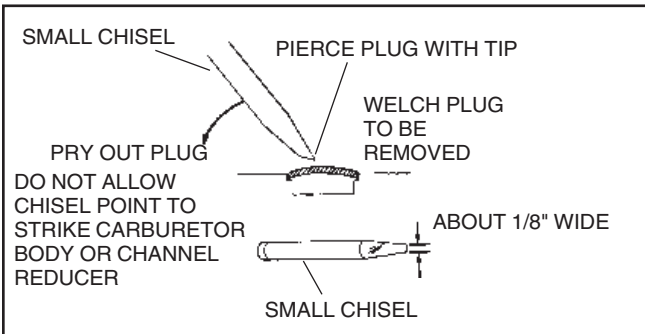

Clean all passages out with soft tag wire. To do a proper cleaning job welch plugs should be removed to expose drilled passages, if equipped. To remove welch plug, sharpen a small chisel to a sharp wedge point. Drive the chisel into the welch plug, push down on chisel and pry plug out of position.

NOTE: Snow King® engines have a primer tube on the carburetor. Make sure this passage is open and replace the hose when servicing.

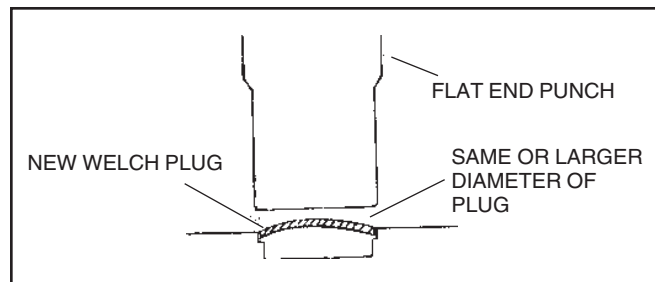

To install a new welch plug after cleaning, place welch plug into mixing well with raised portion up. With a punch equal to the size of the plug, merely flatten the plug. Do not dent or drive the center plug below the top surface of the carburetor. To insure sealing use, nail polish around the plug.

If float sticking occurs due to deposits, or when the fuel tank is filled for the first time, this condition can be quickly corrected by loosening the carburetor bowl nut one full turn. Turn the bowl 1/4 inch in either direction, then return the bowl to its original position and tighten the bowl nut.

SERVICE

CARBURETOR PRE-SETS AND ADJUSTMENT

NOTE: Some carburetors have fixed main and idle jets. The absence of the adjusting screw indicates a fixed jet and no adjustment is necessary.

Before adjusting any mixture screws the necessary carburetor presets should be made. Check for the proper governor adjustments (see governor adjustment section). Identify the correct carburetor model to find locations of the high and low speed adjustment screws. Check the throttle control bracket for proper adjustment allowing a full choke shutter position. (see "Speed Controls and Linkage"). Check to see if the normal maintenance procedures have been performed (oil changed, fresh fuel, air filter replaced or clean). Consult microfiche card #30 to find the correct R.P.M. settings for the engine. RPM specifications can also be found on Plus One or Parts Smart computer programs. Start the engine and allow it to warm to operating temperature. The carburetor can now be adjusted.

Pre-sets and Adjustments If Equipped.

Turn both the main and idle mixture adjusting screws in (clockwise) until finger tight.

NOTE: OVERTIGHTENING WILL DAMAGE THE TAPER PORTION OF THE NEEDLE.

Now back the mixture screws out (counterclockwise) to obtain the pre-set figure in the chart shown at right.

Tecumseh Carburetors		
Engine Model	Main Pre-set	Idle Pre-set
All models with float-type carburetors	1-1/2 turn	1 turn

Final Adjustments

Start the engine and allow it to warm up to normal operating temperature (3 - 5 minutes). Set the speed control to the HIGH or FAST position, then turn the main mixture adjustment screw in (clockwise) slowly until the engine begins to run erratic (lean). Note the position of the screw. Now, turn the screw out (counterclockwise) until the engine begins to run erratic (rich). Turn the screw in (clockwise) midway between these two positions. This will be the best setting.

Set the speed control to the IDLE or SLOW position. Adjust the idle mixture screw following the same procedure used to adjust the main mixture adjustment screw.

Identify the location of both HIGH and LOW speed adjustment screws, then identify the recommended HIGH and LOW R.P.M. setting according to microfiche card # 30 and adjust carburetor accordingly.

TROUBLESHOOTING CARBURETION SERIES I

TROUBLE	CORRECTIONS
Carburetor out of adjustment	3, 4, 11, 12, 13, 15, 19
Engine will not start	1, 2, 3, 4, 5, 6, 8, 9, 10, 11, 12, 14, 15, 16, 17, 19, 20, 23
Engine will not accelerate	2, 3, 4, 5, 11, 12, 15, 19, 23
Engine hunts (at idle or high speed)	3, 4, 8, 9, 10, 11, 12, 14, 19, 20, 23
Engine will not idle	3, 4, 8, 9, 10, 11, 12, 13, 14, 18, 19, 20, 23
Engine lacks power at high speed	2, 3, 4, 7, 8, 10, 11, 12, 15, 18, 19, 20, 23
Carburetor floods	4, 7, 17, 20, 21
Carburetor leaks	4, 6, 7, 10, 17, 18, 22, 23
Engine overspeeds	8, 9, 13, 14, 15, 18, 19
Idle speed is excessive	8, 9, 13, 14, 15, 18, 19
Choke does not open fully	8, 9, 14, 15
Engine starves for fuel at high speed (leans out) ..	1, 3, 4, 5, 6, 10, 11, 15, 16, 17, 18, 20
Carburetor runs rich with main adjustment	7, 11, 17, 18, 20
needle shut off	
Performance unsatisfactory after being serviced ..	ALL

- | | |
|---|---|
| <ol style="list-style-type: none"> 1. Open fuel shut off valve at fuel tank fill tank with fuel. 2. Check ignition, spark plug and compression. 3. Clean air cleaner service as required. 4. Dirt or restriction in fuel system clean tank and fuel strainers, check for kinks or sharp bends. 5. Check for stale fuel or water in fuel fill with fresh fuel/oil mixture of correct ratio. 6. Examine fuel line and pick-up for sealing at fittings. 7. Check and clean atmospheric vent holes. 8. Examine throttle and choke shafts for binding or excessive play remove all dirt or paint, replace shaft. 9. Examine throttle and choke return springs for operation. 10. Examine idle and main mixture adjustment screws and "O" rings for cracks or damage. 11. Adjust main mixture adjustment screw. Check to see that it is the correct screw. 12. Adjust idle mixture adjustment screw. Check to see that it is the correct screw. 13. Adjust idle speed screw. | <ol style="list-style-type: none"> 14. Check position of choke and throttle plates. 15. Adjust control cable or linkage to assure full choke and carburetor control. 16. Clean carburetor after removing all non-metallic parts that are serviceable. Trace all passages. 17. Check inlet needle and seat for condition and proper installation. 18. Check sealing of welch plugs, cups, plugs and gaskets. 19. Adjust governor linkage. 20. Adjust float setting. 21. Check float shaft for wear and float for leaks or dents. 22. Check seal for fuel drain or bowl gasket. 23. Is carburetor operating at excessive angle? |
|---|---|

PISTON AND RINGS

There are various types of piston and ring sets used in 840-850 models, and should not be interchanged.

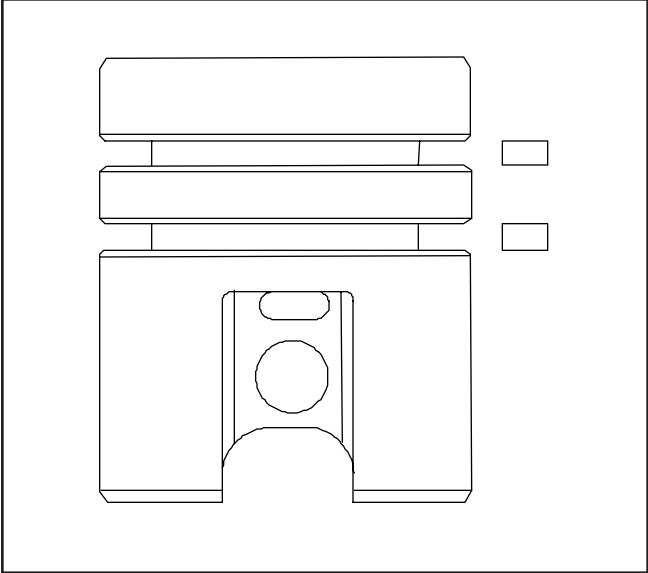

The piston and ring sets on some 840-850's are of a standard type construction. Either ring may be placed in either ring groove of the piston.

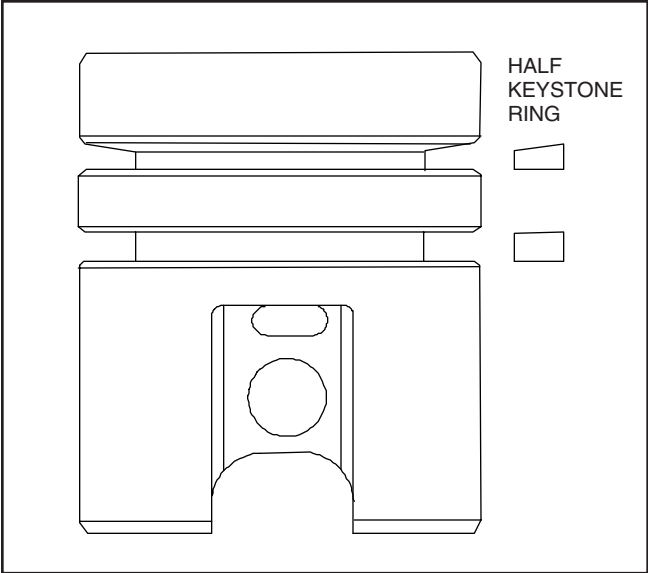

Some 840-850 models use a half keystone upper ring. The ring groove in the piston and on the ring have a distinctive taper to them. The ring must be placed in the top ring groove with the long beveled side towards the dome of the piston as shown.

NOTE: Piston ring end gaps should be staggered upon installation.

E.G.R. TUBE SERVICE & INSTALLATION TVS / TVXL 840 ONLY

NOTE: HXL, HSK840 thru 850 models do not use the E.G.R. system.

An E.G.R. (Exhaust Gas Recirculation) tube is placed in the block of the TVS/TVXL840 engine and extends into the outer chamber of the muffler.

A controlled amount of exhaust gas is drawn into the crankcase of the engine to aid in the movement of the air/fuel mixture to the combustion chamber.

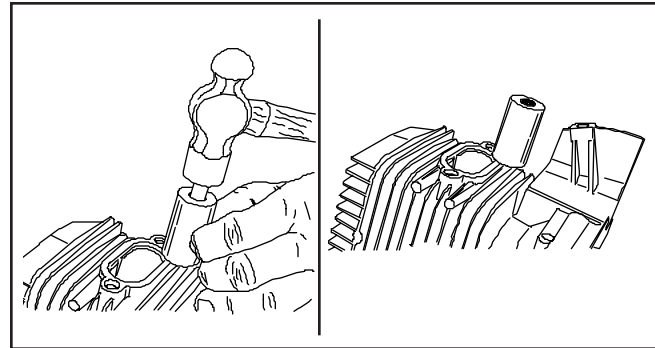
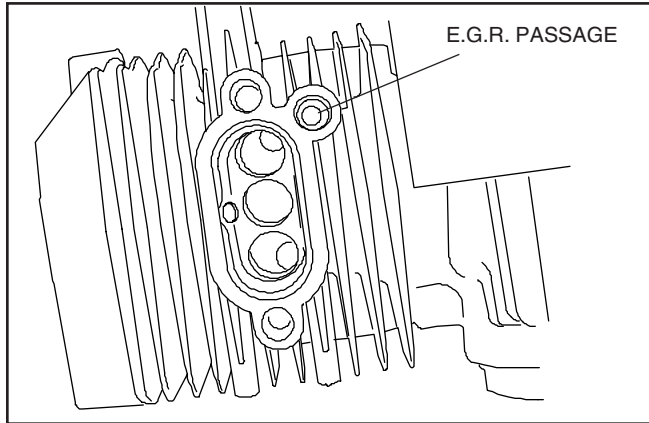

Install the E.G.R. tube in to the proper depth by using service tool number 670318.

PORT PLUG REINSTALLATION

The large transfer port plug's on all 840 series engines are pressed into the block and should not have to be removed.

It is a good idea when decarbonizing the exhaust ports, check the E.G.R. passage as well.

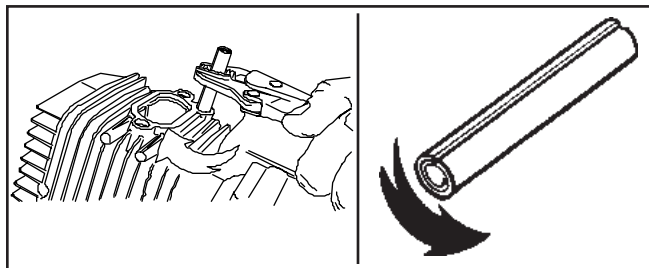

The E.G.R. tube is a hardened steel roll pin. To remove the tube, grasp it with a vise grip and rotate in the direction that will collapse the tube and allow it to be removed.

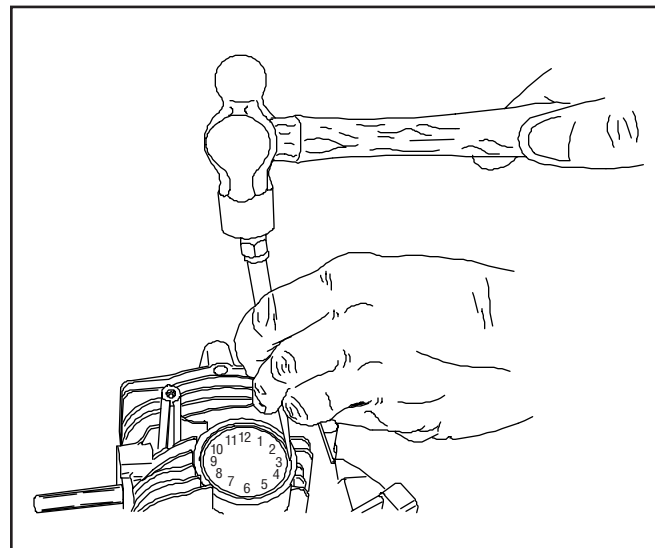

However, if for any reason the plug should come out of the engine, it can be reinstalled. Clean the block and the port plug with lacquer thinner or comparable product so that it is free of all oil.

Using a small, thin center punch or large scribe, stake the port plug in 12 evenly spaced positions.

Use 5 minute epoxy and fill in around the outer diameter of the plug. This will ensure you have no air leaks.

Allow epoxy to cure for 24 hours before using engine.

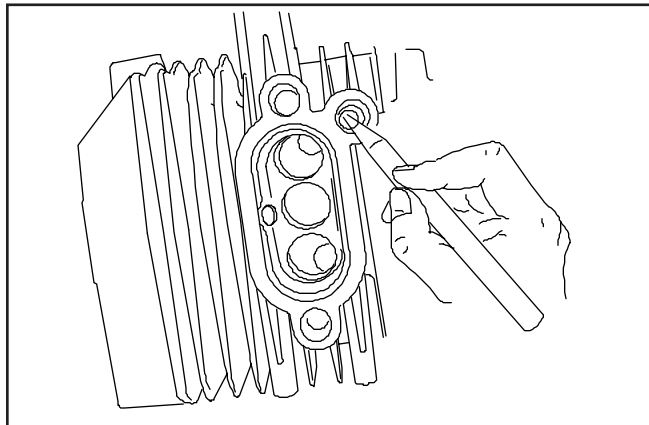

It is best to clean this passage when the piston is out of the bore to eliminate any possible damage to the piston or bore. Use any non-metallic material and clean the E.G.R. port in the cylinder.

ANTI-PUDDLING METER HOLE SCREEN

NOTE: This section applies to TVS, TVXL840's only.

TVS / TVXL840 engines built since 1/1/87, serial numbers 7001 and thereafter, have a screen pressed into the cavity below the anti-puddling meter hole.

This screen is a precautionary measure against abuses such as contaminated fuel or in some instances customers removing air cleaner elements allowing contaminants to enter the crankcase. Engines built prior to 1/1/87 can also have a screen installed. Part No. 430233 can be installed using the following procedure.

1. Disassemble engine so the piston, rod and crankshaft assembly can be removed.

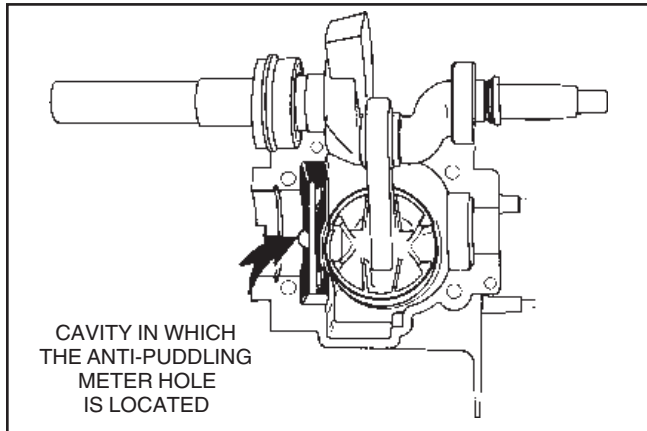

2. After removing the crankshaft assembly, clean the anti-puddling meter hole with a soft tag wire. Probe the hole several times to assure proper cleaning. The hole is located between the shelf and PTO end of the block directly under the governor lever.

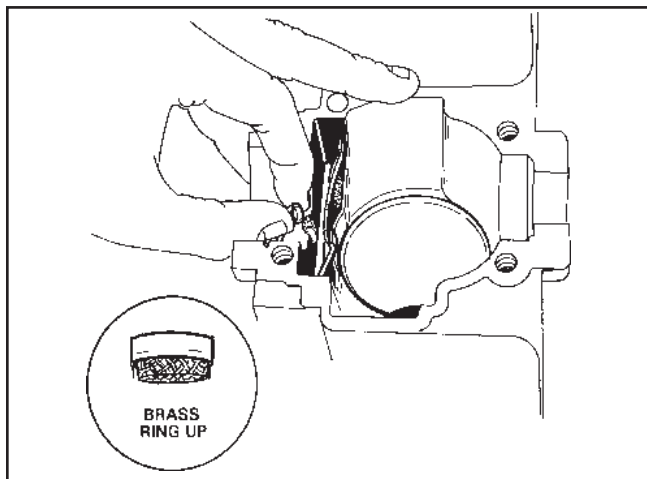

3. Insert the screen past the governor lever into the tapered cavity with brass ring up. Use a small punch or scribe to seat the screen squarely. Be careful not to bend or poke a hole in the screen.

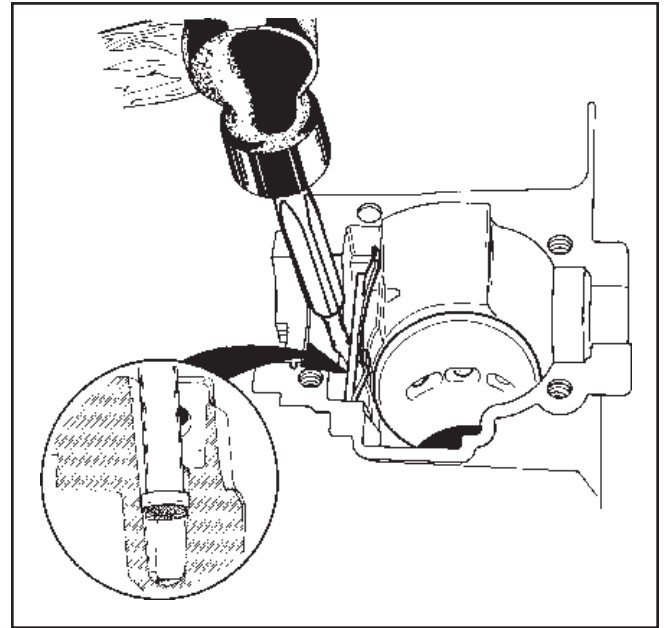

4. With the screen in place, take a 1/4" roll pin punch, place it on top of the screen and tap until the screen is seated securely in the hole.
5. Reassemble the engine as stated in that section of this book. Engines built after 1/1/87 (serial numbers 7001 and beyond) have a screen installed in production.

REPLACEMENT OF SCREEN

If the anti-puddling meter hole screen becomes clogged with debris, a wire hook can be used to remove the screen. The same procedure as outlined in this section should be followed for reinstallation of the new screen.

SELF-ENERGIZING BRAKE SYSTEM

TVS/TVLX840 Models

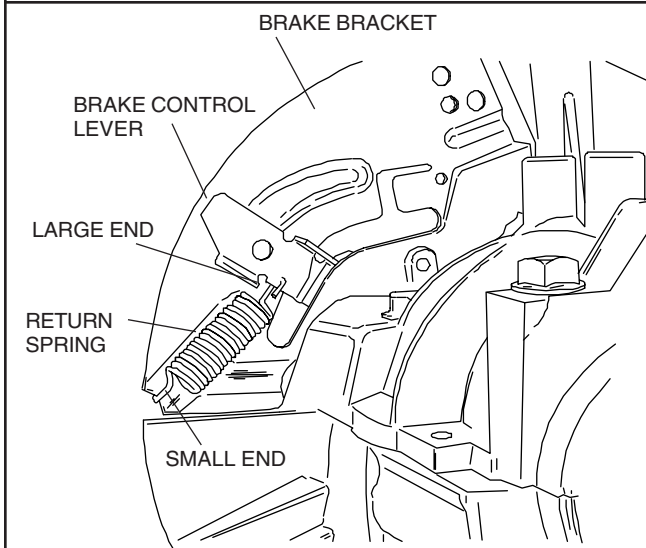
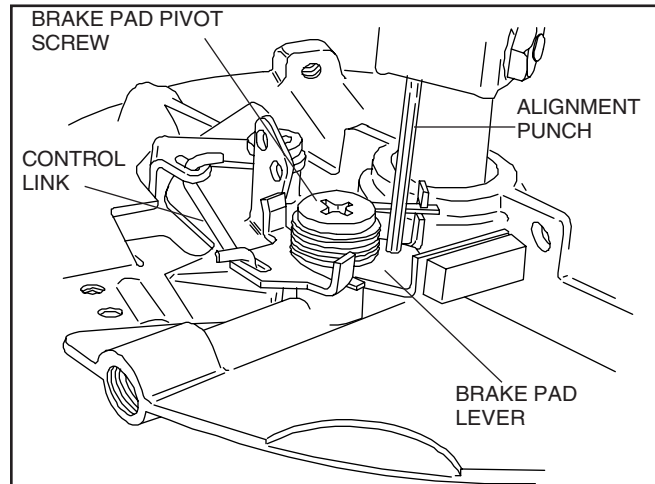
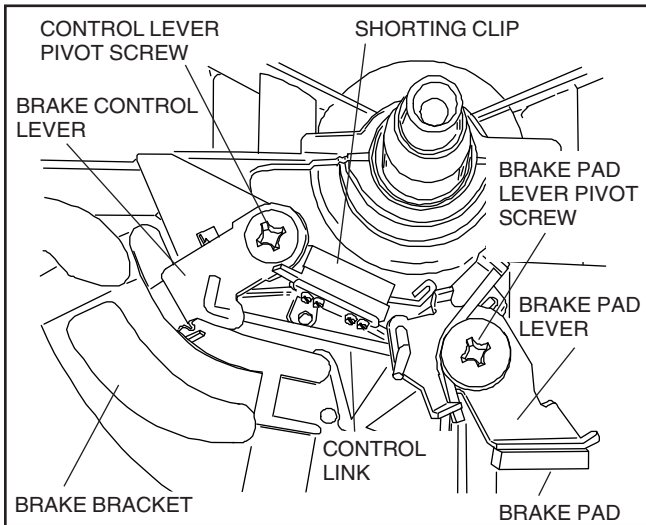

4. Align the hole in the brake pad lever to the hole in the bracket and hold in this position with a small punch.
5. Remove the control lever pivot screw.
6. Disconnect the control link from brake pad lever. Remove punch.
7. Remove brake pad lever pivot screw.
8. Turn the brake spring so the small arm (on the bottom) clears the notch in the brake pad lever.

These are the components of the self-energizing brake system.

DISASSEMBLY OF THE BRAKE SYSTEM.

1. Disconnect the grounding wire from the shorting clip.
2. Press the shorting clip out of the brake bracket.
3. Unhook the return spring from the brake bracket.

REASSEMBLY OF THE BRAKE SYSTEM.

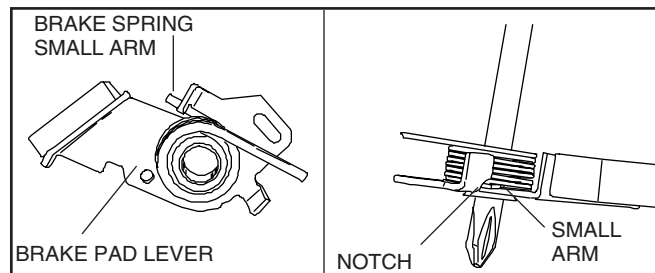

1. Position brake spring on brake pad lever with small extension of spring into notch on pad arm.

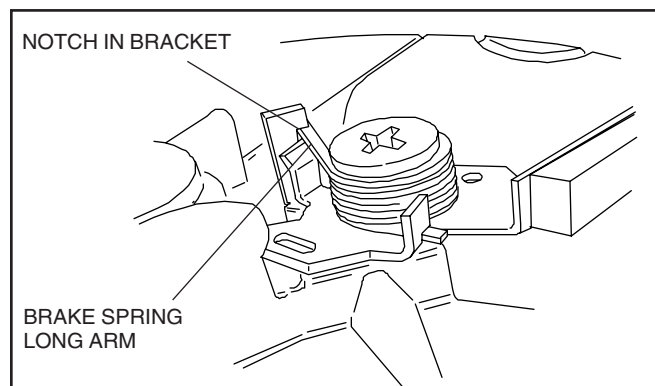

2. Assemble the brake pad lever and spring assembly to the bracket with the pivot screw. Position the long extension from the brake spring into the notch on the bracket.
3. Position the control lever in the brake bracket.

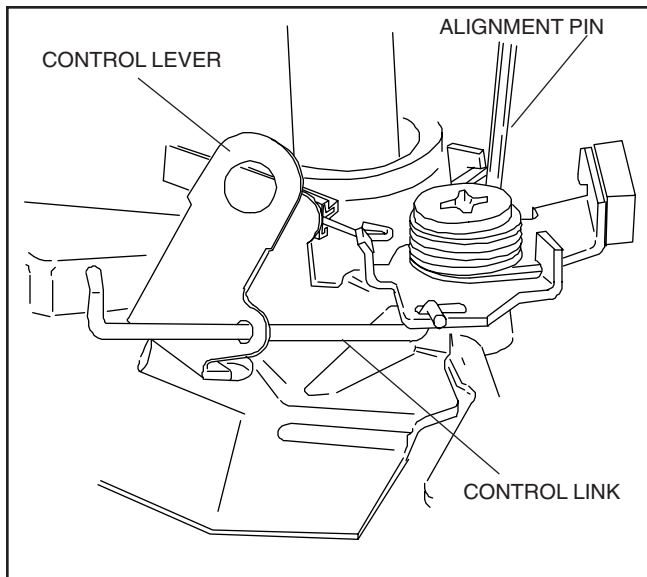

4. Align the hole in the brake pad lever to the hole in the bracket with a small punch.
5. With the short side up, slide the control link through the slotted hole of the control lever. Place opposite end of link into slotted hole of brake pad lever short side up.
6. Slide control link to its proper position in the control lever.
7. Position control lever and pivot screw.
8. Tighten both pivot screws, and remove alignment punch.

CAUTION: Secure the screws with red Loctite. DO NOT over torque or the brake pad will be distorted. Then a new pad and lever assembly will be required.

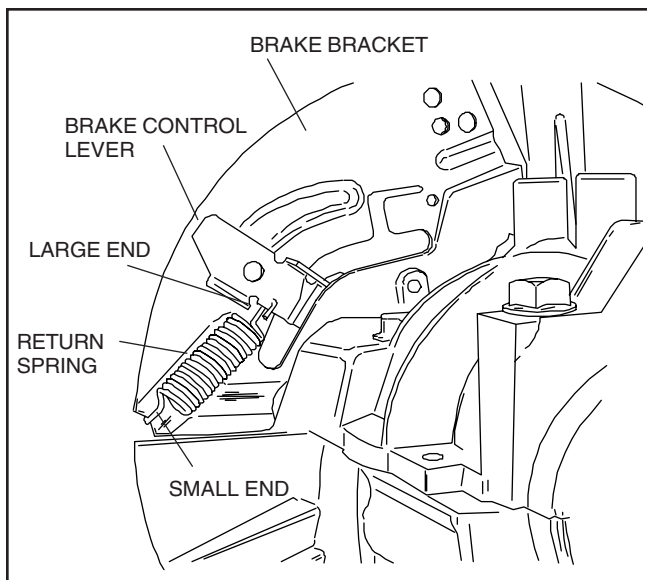

9. Place large end of return spring in hole of control lever, short end of spring on the notch in the brake bracket.
10. Reposition shorting clip and attach grounding wire.

GOVERNOR LINKAGE, AND ADJUSTMENT

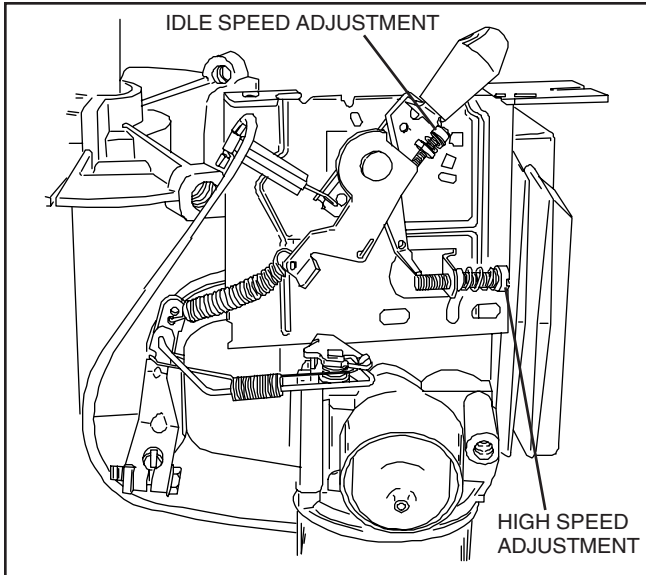

LINKAGE LOCATION. To aid in the proper reassembly of the governor linkage, mark the linkage locations.

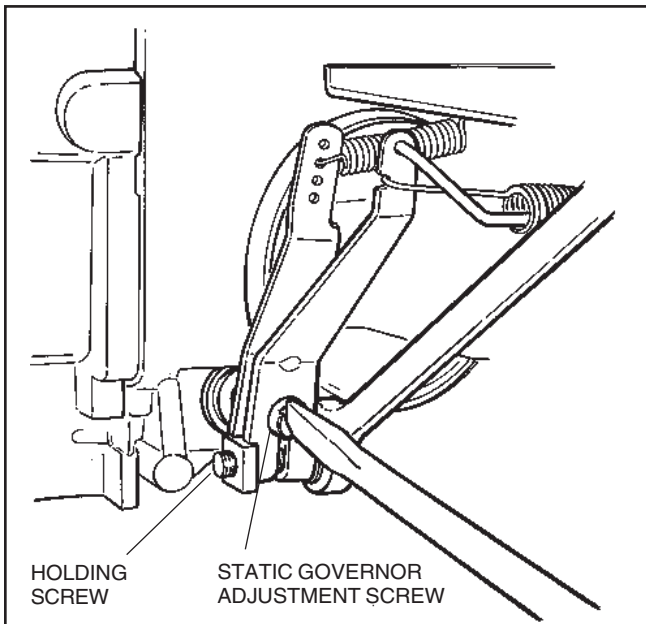

GOVERNOR ADJUSTMENT. To adjust the governor, move the throttle to the wide open position. Loosen the holding screw, turn the slotted governor shaft clockwise as far as it will go without forcing it. Then tighten the holding screw.

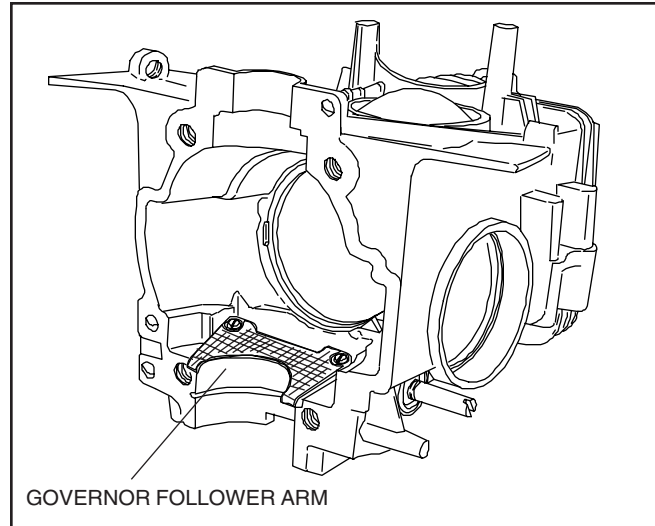

GOVERNOR FOLLOWER ARM AND SHAFT ASSEMBLY. The governor following lever and governor shaft can be serviced by removing the two screws in the following lever and shaft. Reassemble the following lever and governor shaft so that curved end of the following lever points toward the P.T.O. end of the engine.

New service screws should be used when the old screws are removed. The new service screws have a dry adhesive applied to them to prevent them from coming loose. This is the same screw that is used on the choke and throttle plates in the carburetor.

GOVERNOR SHAFT SEAL. The governor shaft seal may be pressed in until it seats in the boss of the block. Care should be used when this seal is replaced, forcing the seal to far into the block will distort the seal and cause it not to seal the governor shaft.

GOVERNOR LINKAGE AND ADJUSTMENT

HXL, HSK840 - 850

The following are controls used on HSK and HXL models.

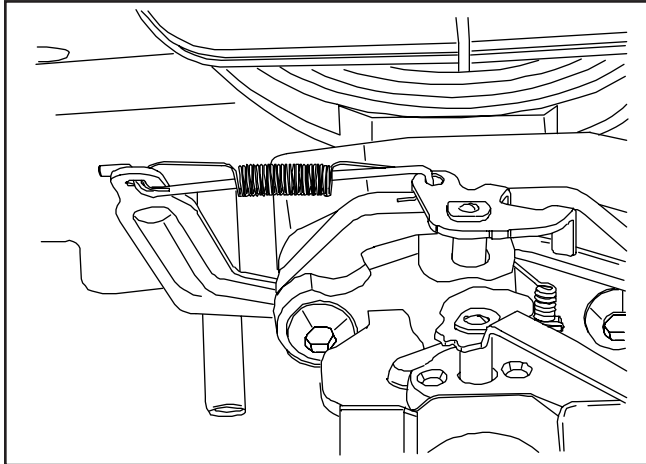

Fixed speed governor linkage hooks.

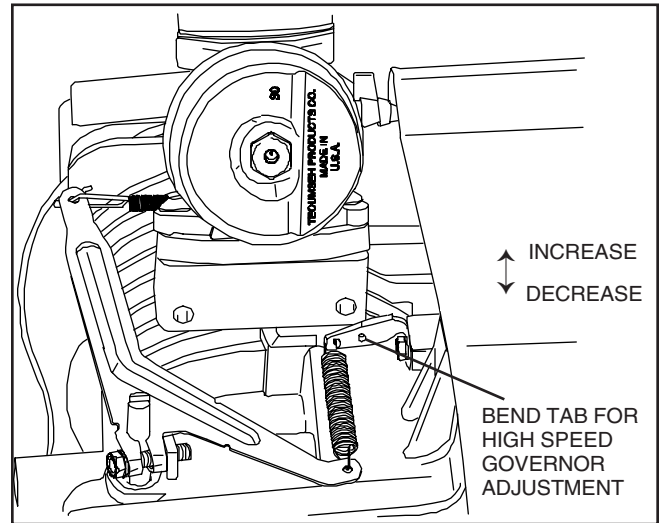

RPM adjustment of fixed speed models is done by bending at the tab as shown.

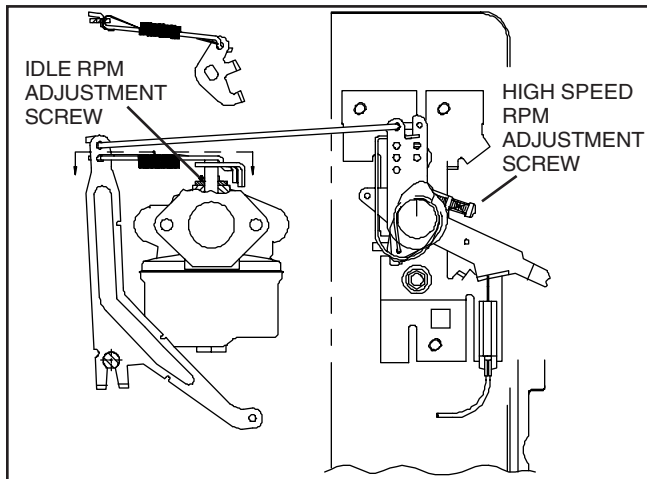

The HXL840 - 850 Series with variable speed control have the following adjustments. Idle speed is set at the carburetor crack screw. High speed is set with the screw shown above. Always check Microfiche card 30, Plus One or Parts Smart computer program for correct speed settings.

REWIND STARTER

TYPE I

The rewind starter on the engine can be disassembled by using the following steps.

1. After removing the rewind from the engine blower housing release the tension on the rewind spring.
2. Place a 3/4" deep reach socket inside the retainer pawl. Set the rewind on a bench, supported on the socket.
3. Using a 5/16 roll pin punch, drive out the center pin.
4. All components that are in need of service should be replaced.



THIS REWIND SPRING IS NOT IN A CANISTER. Care must be used when handling the pulley because the rewind spring and cover is held by the bosses in the pulley.

TO REASSEMBLE THE REWIND STARTER:

1. Reverse the above listed procedure keeping in mind that the starter dogs with the dog springs must snap back to the center of the pulley.
2. Always replace the center pin with a new pin upon reassembly. Also add an additional plastic washer (two total) upon reassembly. This washer will be provided along with the new center pin.
3. Check retainer pawl. If it is worn, bent or damaged in any manner replace upon reassembly.

Tap the new center pin in until it is within 1/8 of an inch of the top of the starter.

CAUTION: Driving the center pin in too far will cause the retainer pawl to bend and the starter dogs will not engage the starter cup.

TYPE II

Starters use a new wedge and post system which is serviced in the following steps.

1. Remove decal covering the pin wedge.
2. Use a small screw driver to pry out the wedge.
3. Next use a needle nose pliers to compress the retainer assembly and push it out.
4. Inspect all parts and replace using the Parts Look Up system by model and specification numbers.
5. Always replace the retainer and retainer wedge.

NOTE: Snow King® recoil springs have a specially designed recoil pulley with a frost ring.

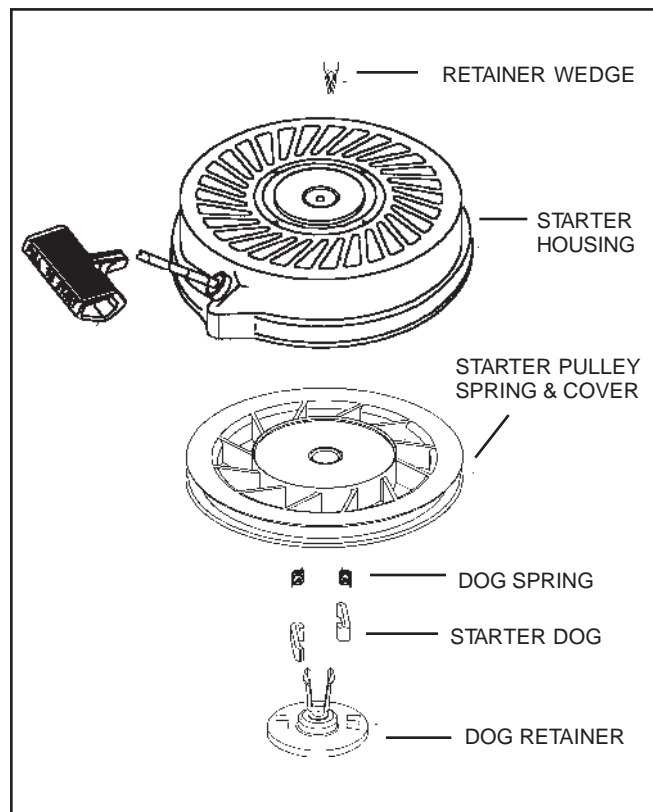
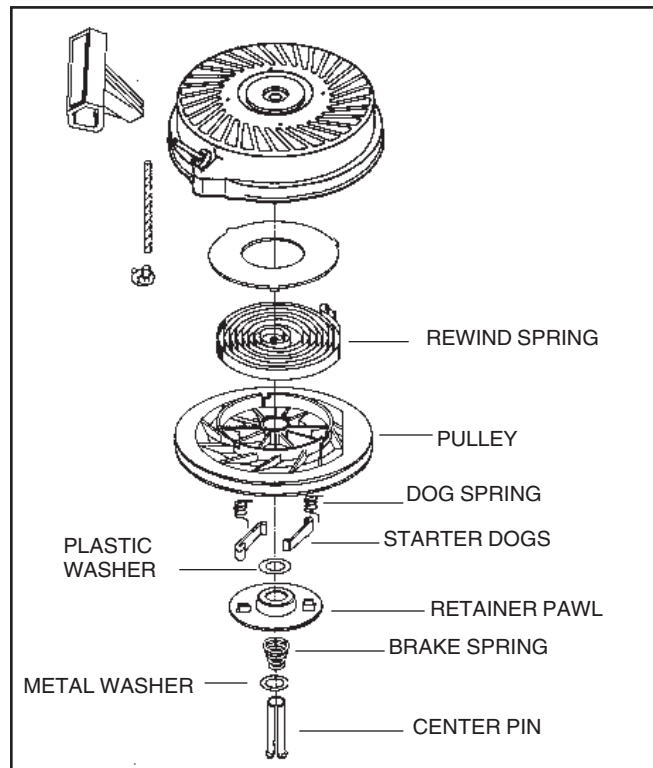

840 - 850 DISASSEMBLY

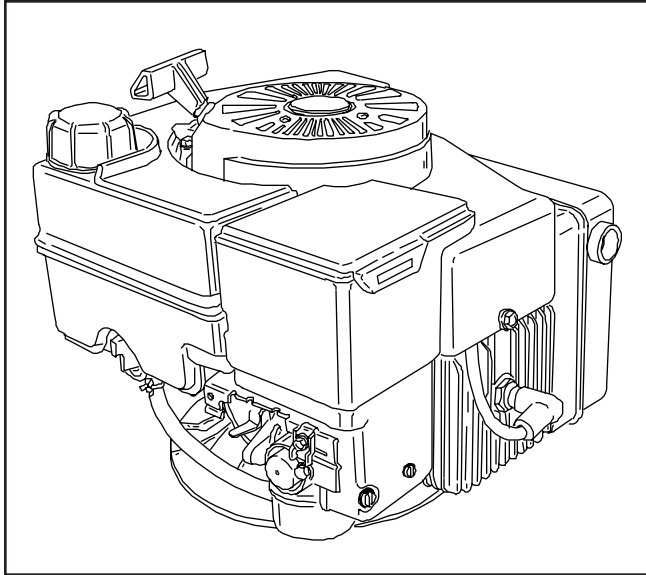

MODEL 840-850 DISASSEMBLY. Disconnect the high tension lead from the spark plug. Remove the spark plug with a 3/4" deep reach socket.



Before removing the fuel tank, drain the fuel into an approved container outdoors, away from any open flame.

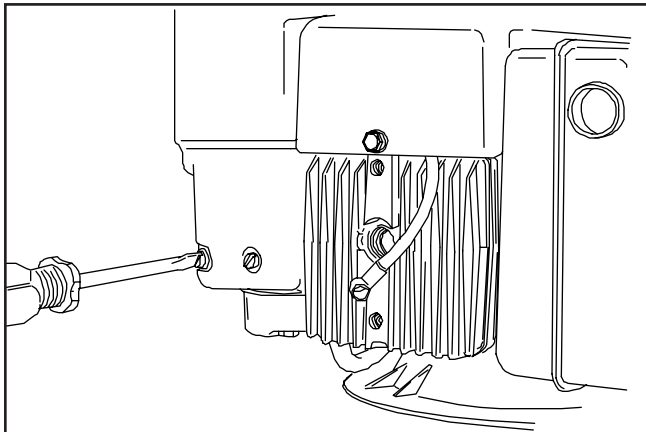

Using a screwdriver remove the 2 screws holding the air cleaner assembly to the carburetor body. Then remove the air cleaner assembly from the engine.

Remove the carburetor and intake/reed assembly if equipped.

NOTE: The horizontal 840 thru 850 engines use a piston port intake system and do not have reed block.

EXHAUST PORT CLEANING

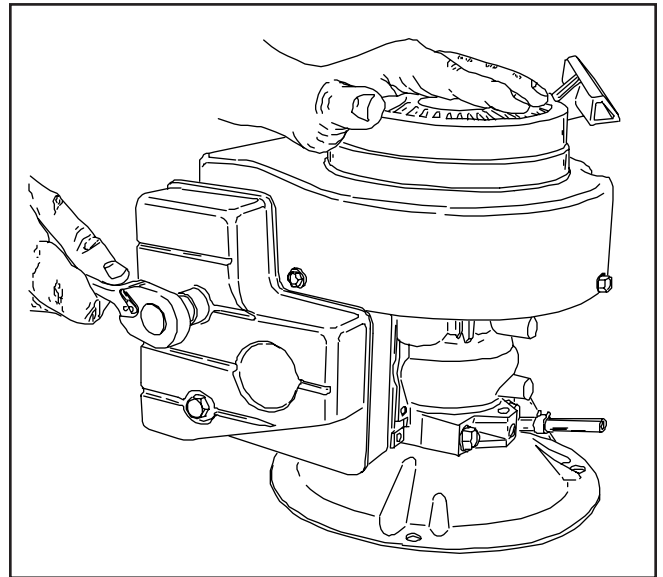

Remove the muffler and gasket from the engine.

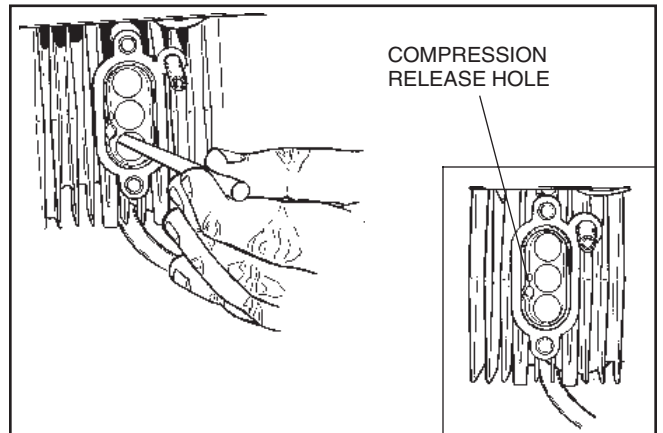

EXHAUST PORT CLEANING. The exhaust ports should be cleaned after each seventy-five (75) to one hundred (100) hours of use.

Before cleaning the ports place the piston in the Bottom Dead Center position. Then clean the ports using a pointed 3/8" diameter wooden dowel or similar tool. Be sure not to scratch the port area. Also remember to remove all the loose carbon particles from the engine.

NOTE: The small compression relief hole drilled up into the cylinder must be checked as well. This hole allows for easy starting.

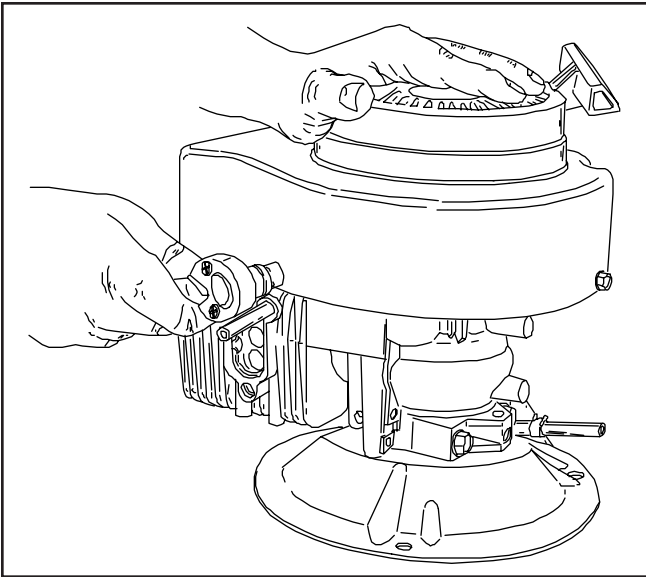

Remove the 4 screws that hold the blower housing in place and remove the housing from the engine.

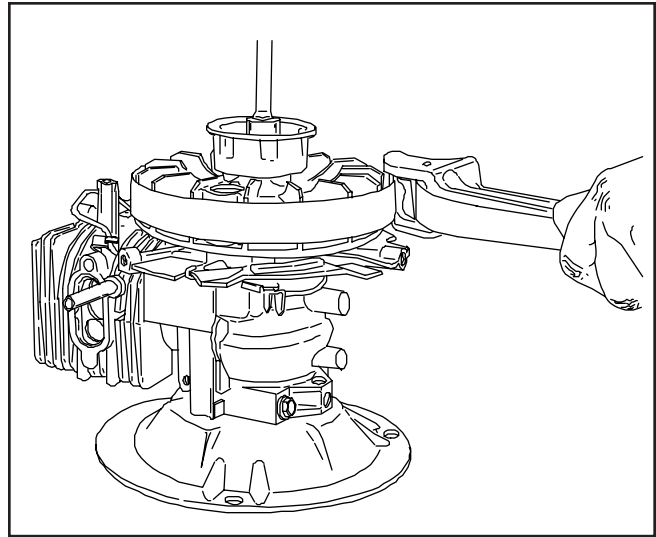

Use strap wrench #670305 to hold the flywheel while removing the flywheel nut.

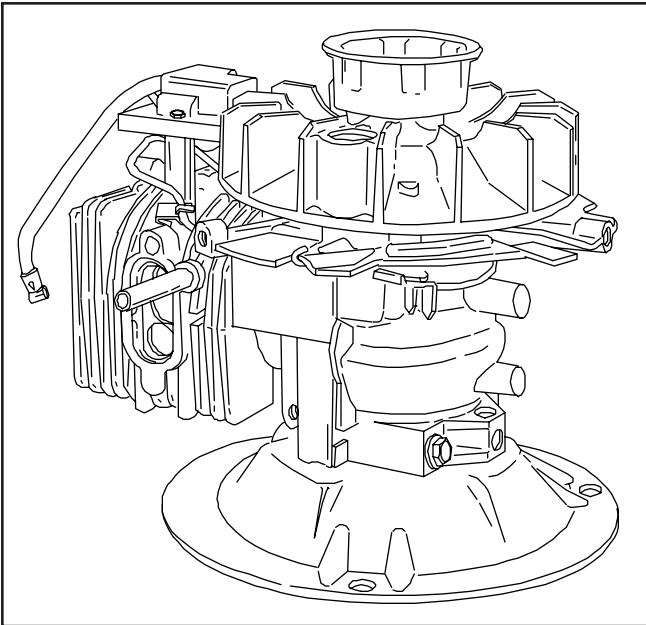

Check the routing of all the wires from the Solid State Ignition unit before removing them from the unit. Then remove the solid state module from its posts.

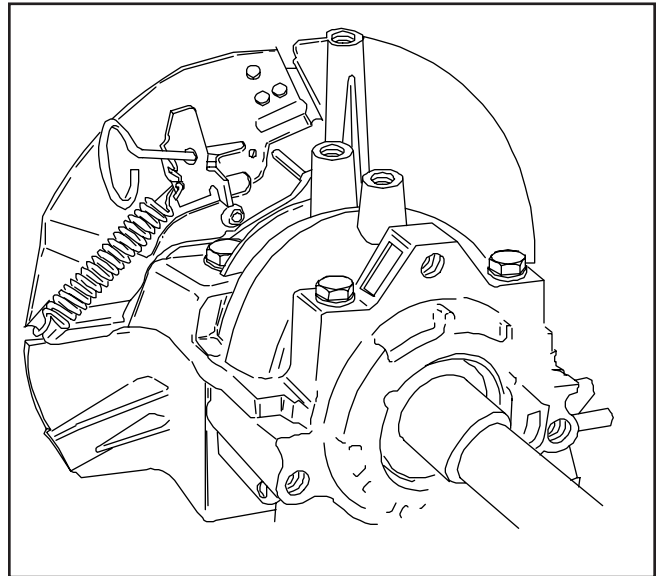

On TVS/TVXL Models before removing the flywheel, the brake pad must be disengaged from the inside of the flywheel. If this is not done damage could occur to the brake system.

To disengage the brake pad from the flywheel, pull the brake lever away from the return spring as far as it will go. Place an alignment pin through the lever hole so it catches on the shroud. This will hold the pad off the flywheel.

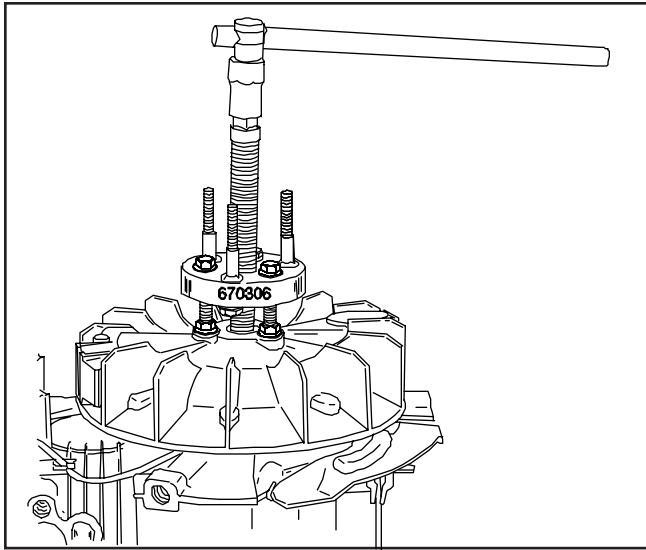

Use flywheel puller #670306 to remove the flywheel. DO NOT USE A KNOCKOFF TOOL.

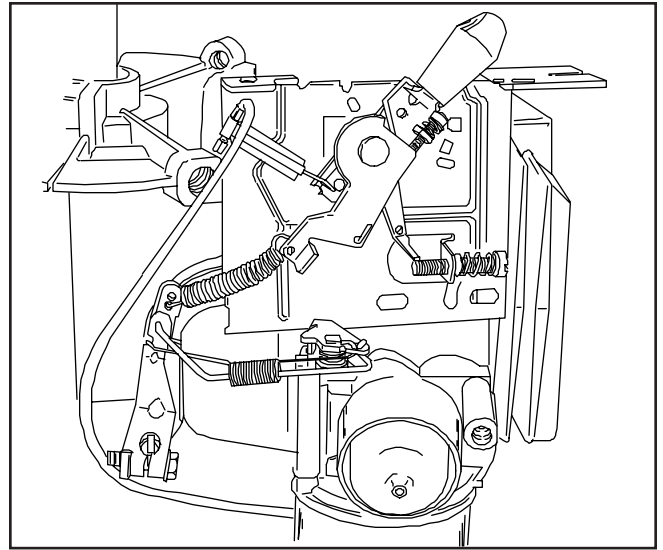

BE SURE TO MARK LINKAGE CONNECTIONS.

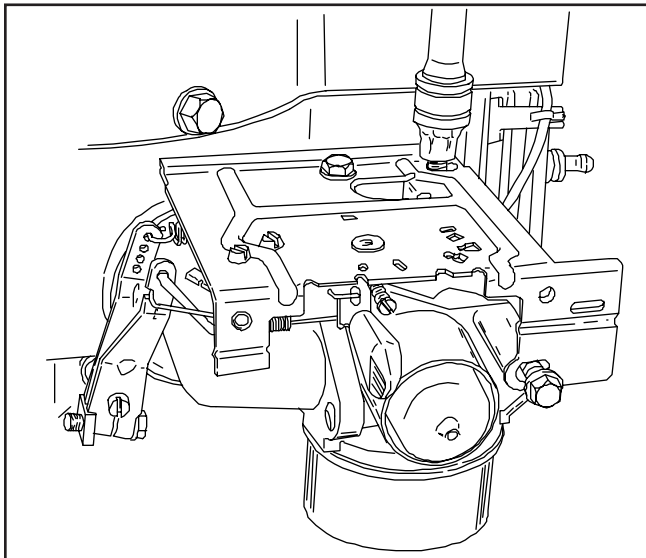

On TVS/TVXL840 models remove the 3 screws that hold the speed control to the block.

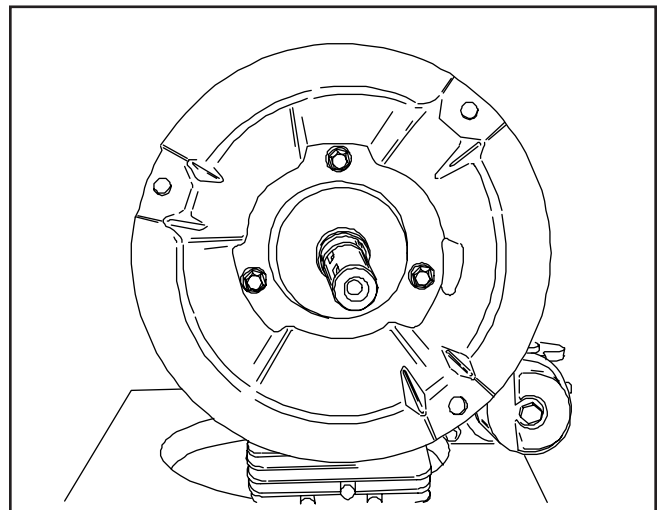

On TVS/TVXL840, after removing the 3 screws from the PTO mounting adaptor, it may be necessary to tap lightly on the ring with a rawhide mallet to remove it.

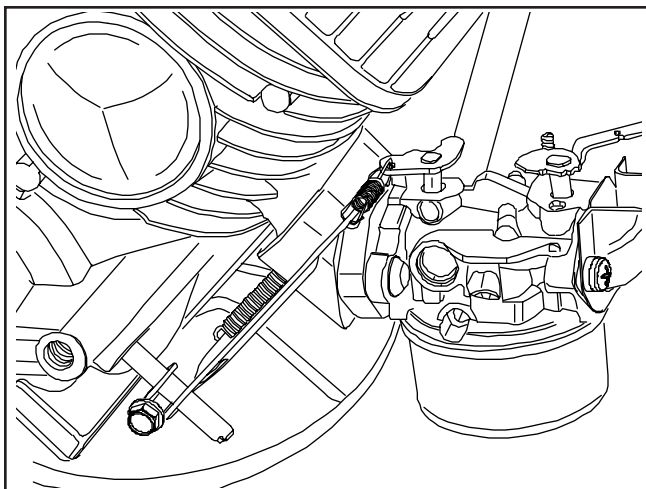

Remove governor linkage on HSK model, always mark all spring and linkage positions

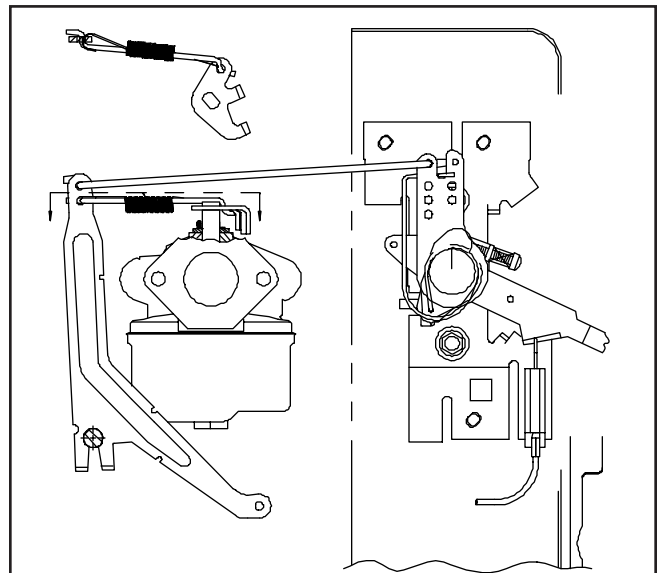

Remove governor linkage on HXL model with variable speed.

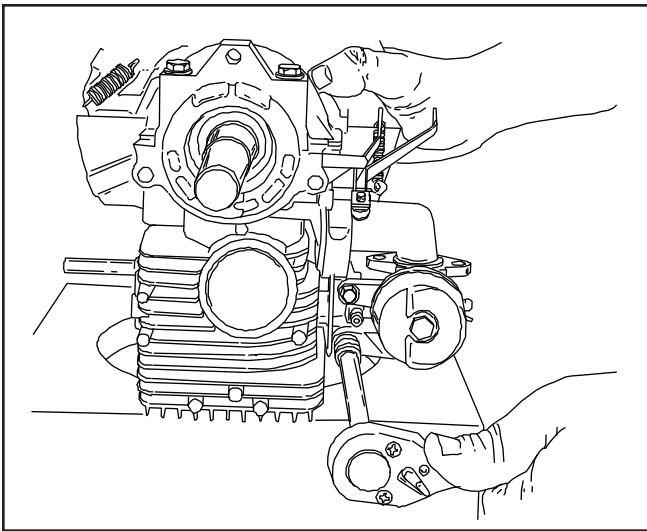

On TVS/TVXL840 models, the 2 bolts that hold the carburetor to the cylinder can be removed. Notice the position of the fiber washers on the carburetor screws. These are for vibration and must be re-installed on assembly between the carburetor and block.

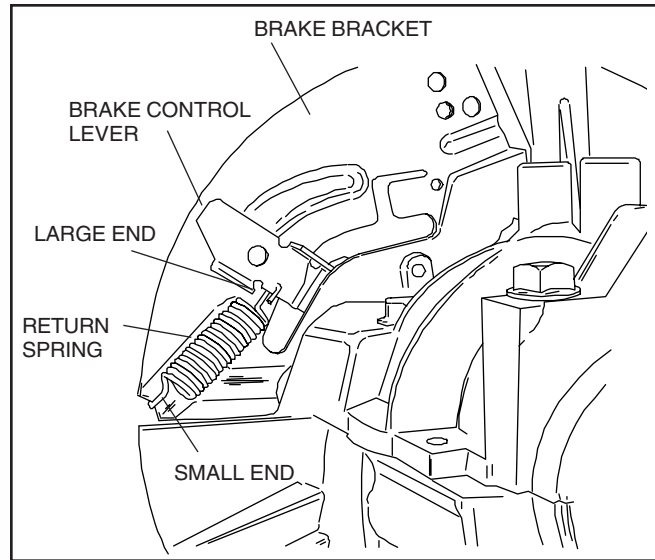

Examine the positioning of the brake assembly components before removing the assembly. For disassembly instructions see Self-Energizing Brake System in this manual. (TVS/TVXL models only)

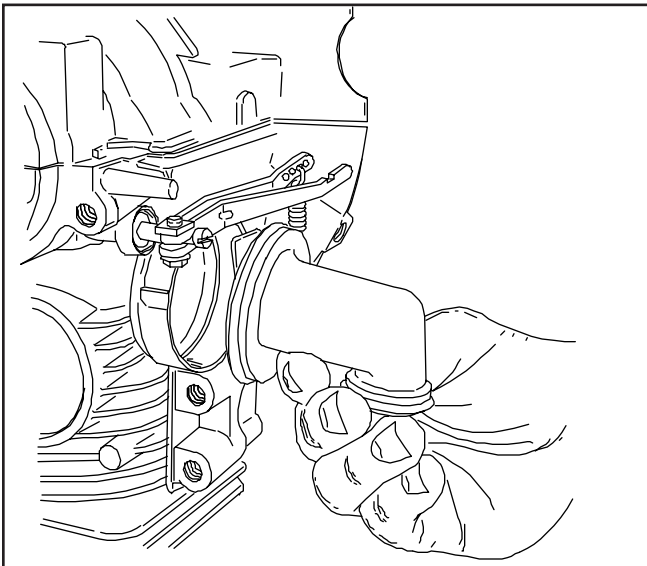

TVS/TVXL models, pull the intake elbow out of it's cavity. Discard the rubber "O" rings. Examine the reed valve for damage and wear. If reed clearance is .020" or more replace the intake elbow.

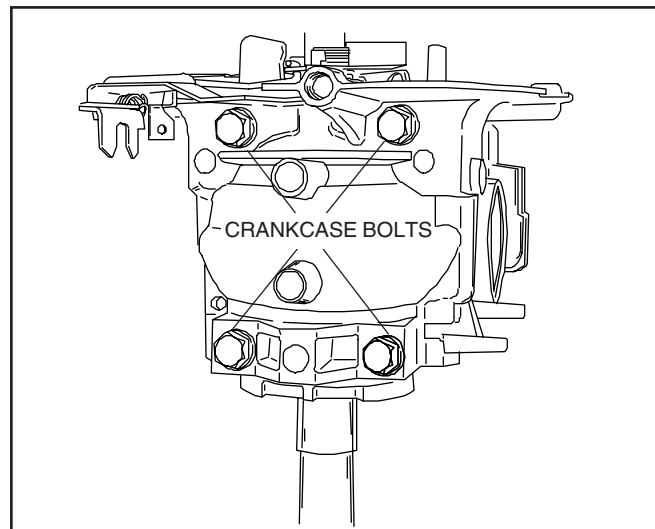

This engine has a split crankcase. To service the internal components of this engine, remove the 4 bolts that hold the crankcase cover to the cylinder. Then lift the crankcase cover off the cylinder.

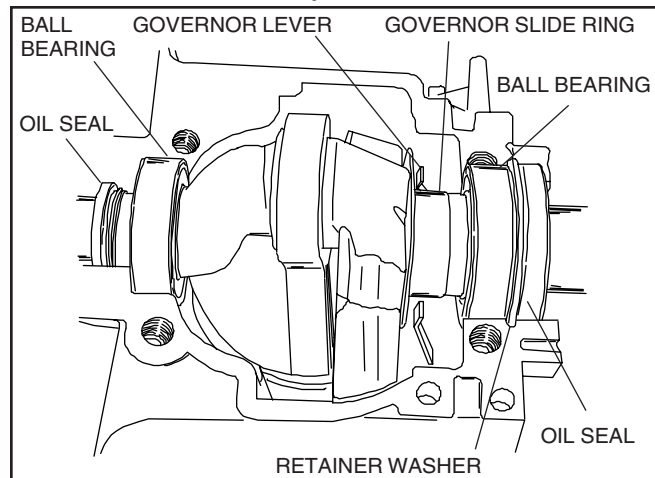
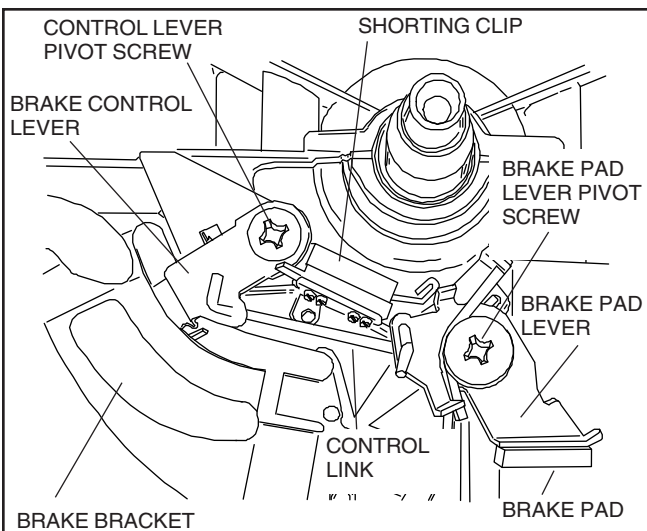

With the crankcase cover removed the positioning of the internal components can be noted.

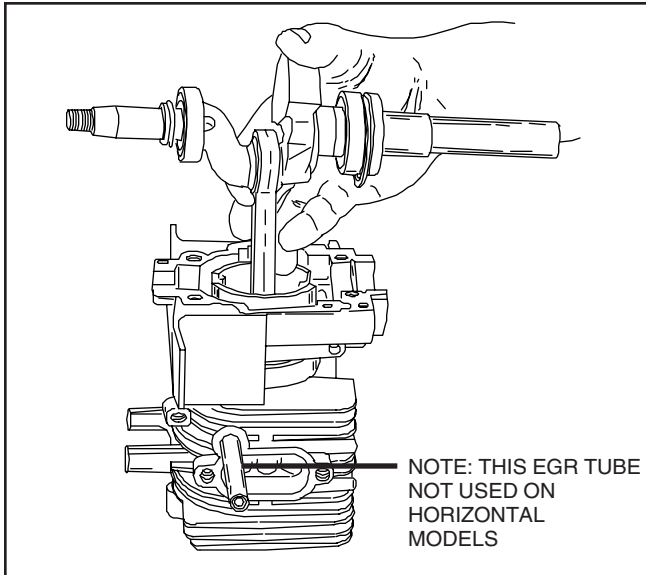

To be sure you don't drop any of the needle bearing needles, follow these steps. First rotate the piston towards the spark plug. Next hold the rod against the crankshaft counter weight and pull the assembly out.

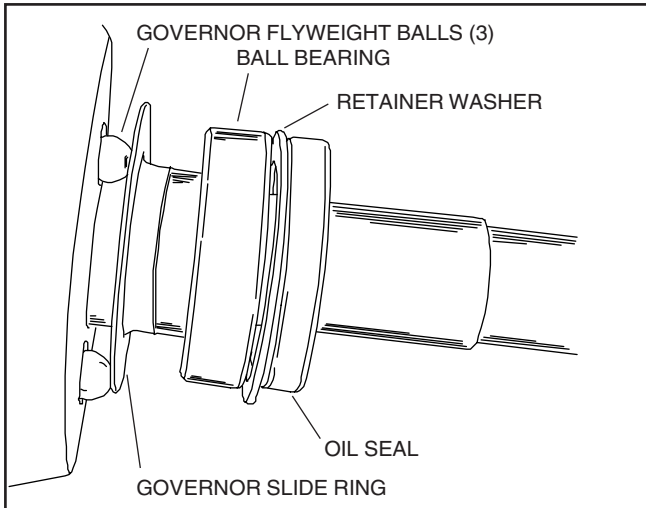

The proper positioning of the PTO side oil seal, retainer washer and ball bearing are shown here. Along with the governor slide ring which is a component of the engines Mechanical Governor System. To remove all of these components simply slide them off the PTO end of the crankshaft.

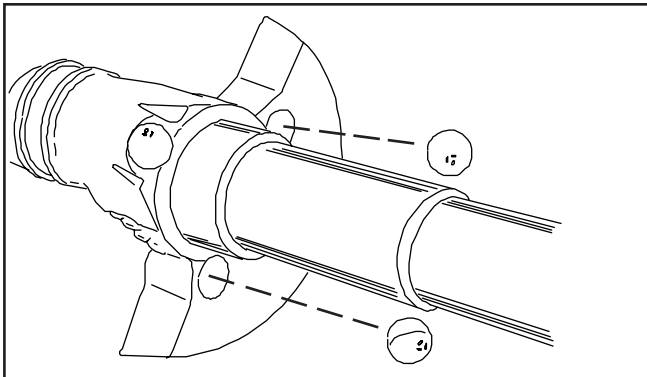

After removing the governor slide ring the governor flyweight balls can be removed and replaced if necessary.

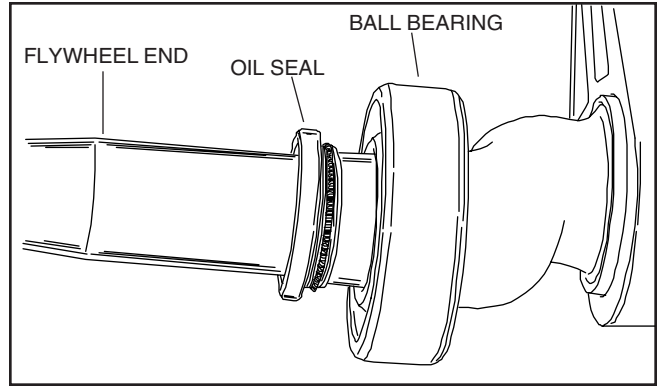

Remove the oil seal and ball bearing from the flywheel end of the crankshaft.

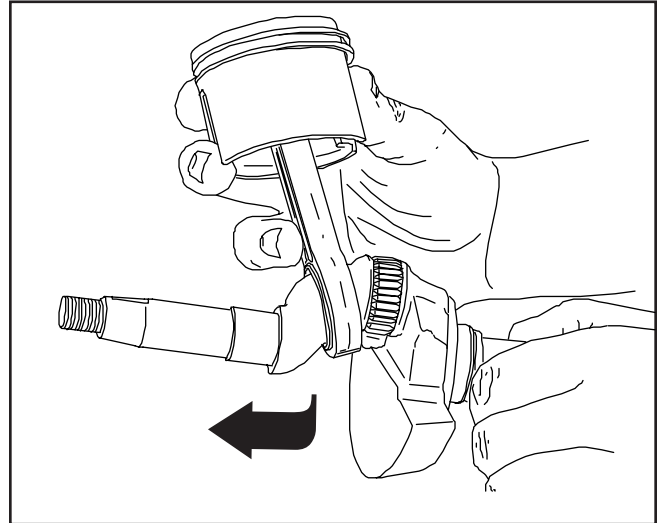

Slide the piston and connecting rod off towards the flywheel end of the crankshaft.

IMPORTANT: The crankpin needles are loose, not caged! Collect and count the needles. There should be 31.

NEVER REUSE OLD NEEDLES.

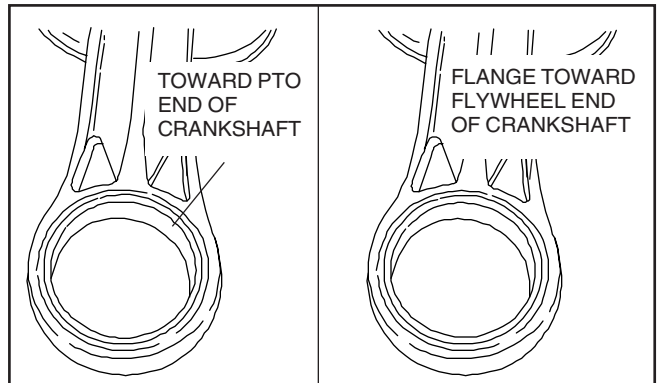

The connecting rod has a pressed in steel bearing liner. Notice that the flange of the connecting rod liner faces the flywheel end of the crankshaft.

840 - 850 REASSEMBLY

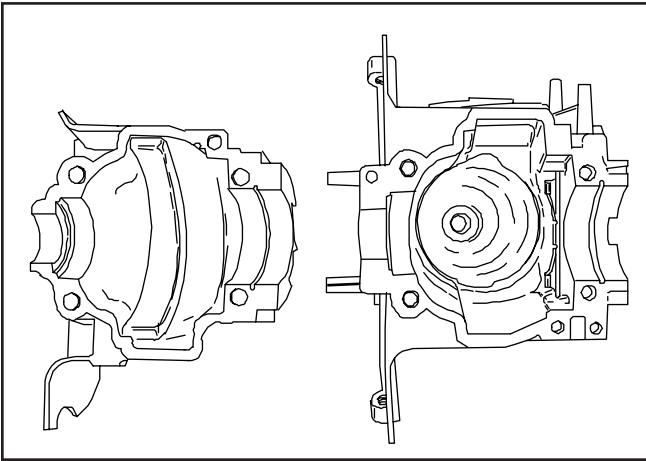

840 HORIZONTAL AND VERTICAL REASSEMBLY. Apply cleaning solvent to the mating surfaces of the cylinder and crankcase, and allow to stand for a few minutes. If scraping is required, avoid causing any scratches or burrs.

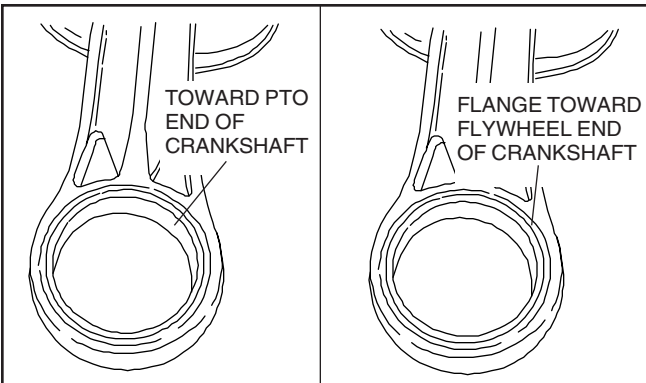

On older units the flange side of the rod race must face toward the flywheel end of the crankshaft.

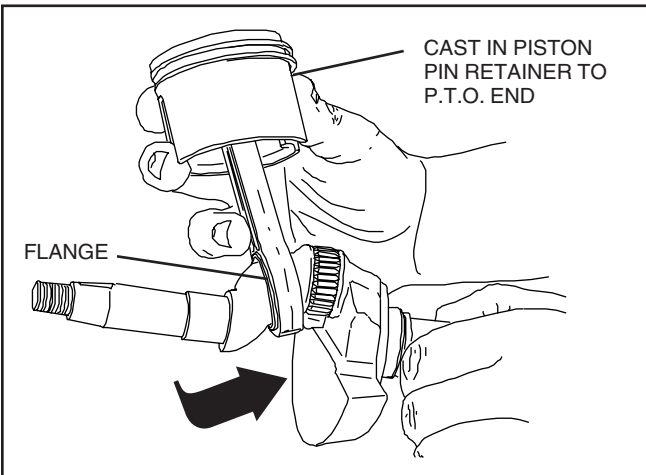

After installing a new strip of needle bearings (31 needles) position the piston and connecting rod on the crankshaft, making sure the flange side of the rod liner is toward the flywheel end of the crankshaft. On newer units the connecting rod flange is less noticeable and will require the cast in side of the piston pin retainer to face the PTO end of the crankshaft.

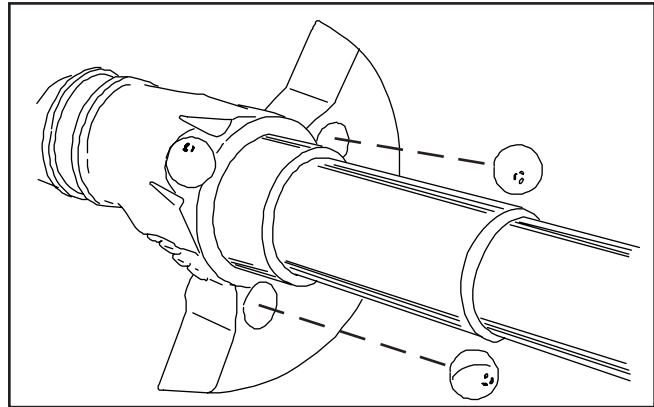

Reposition the 3 governor flyweight balls in the crankshaft.

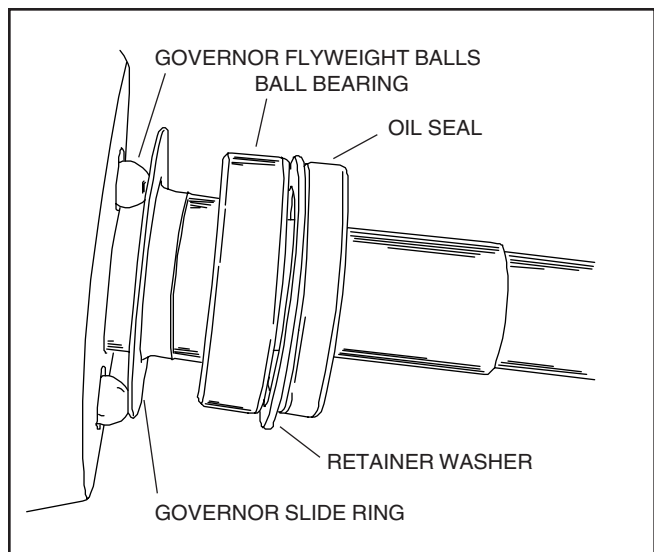

Place the governor slide ring on the PTO end of the crankshaft so the flat portion covers the flyweight balls. Then position the ball bearing, retainer washer and large oil seal as shown. Use seal protector #670265 when positioning the oil seal.

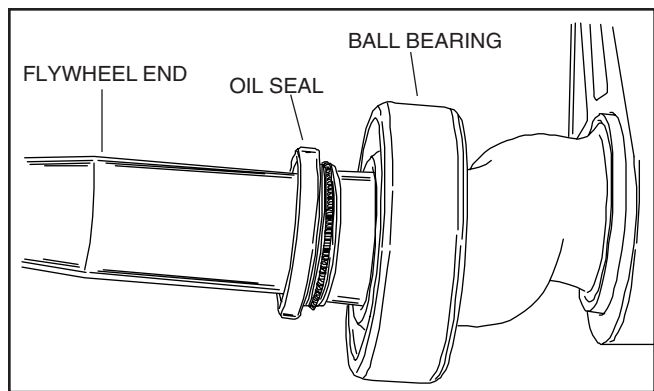

Reposition the ball bearing and oil seal on the flywheel end of the crankshaft.

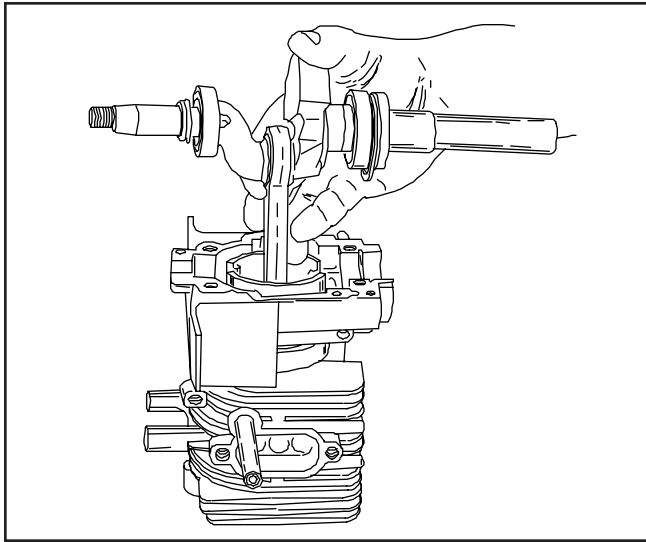

If piston rings need assistance to go in, use a hard wooden wedge made from a dowel.

Place the complete crankshaft and piston assembly into the cylinder. Make sure to stagger the ring end gaps. The tapered edge of the cylinder will compress the rings. Use care not to damage the connecting rod.

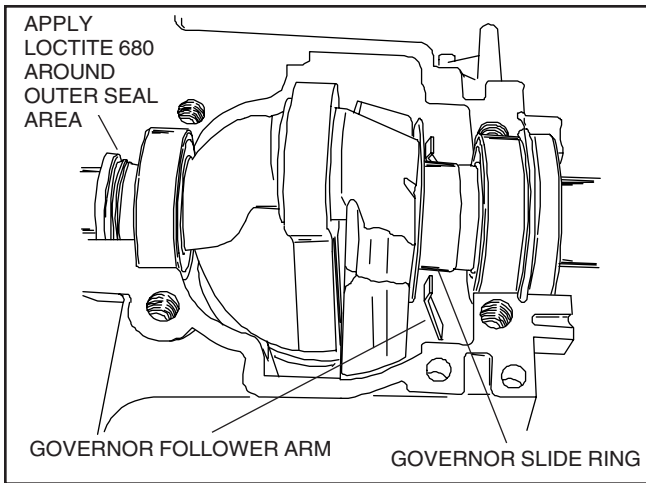

Position the governor following lever so it rides on the PTO side of the slide ring.

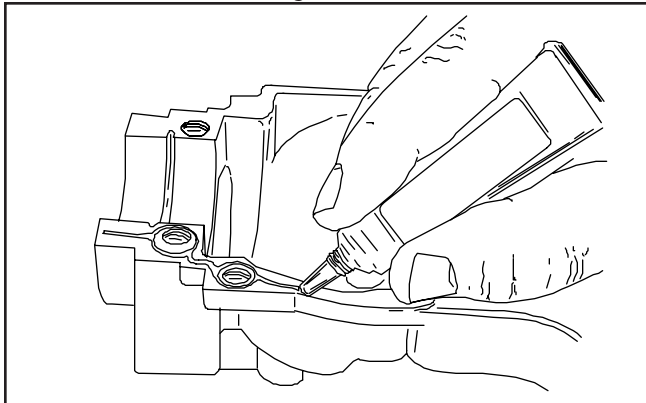

Before replacing the crankcase cover, apply a thin layer of Loctite #515 Gasket Sealant Eliminator (Tecumseh part #510334) around the crankcase, completely covering the mating surface.

NOTE: LOCTITE 680 MUST BE USED AROUND THE OUTSIDE FLYWHEEL END SEAL FOR RETENTION.

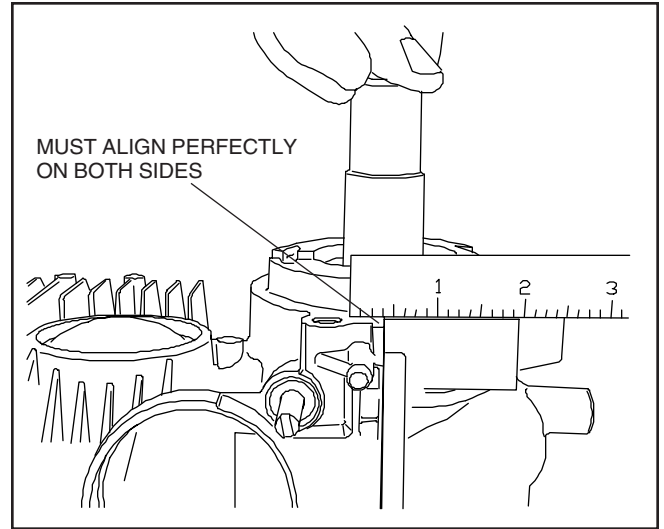

It is critical the crankcase cover be aligned to the crankcase at the PTO end. This can be accomplished by checking with a straight edge or by using a 1/4" alignment tool such as the shank end of a drill.

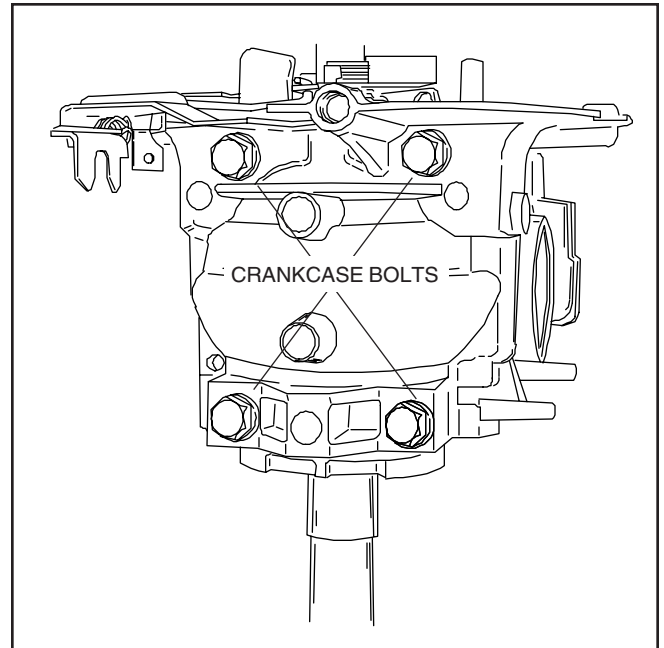

Reassemble the crankcase cover to the cylinder.

Torque in increments of 50 inch pounds to the requirement listed in the table of specifications.

TVS/TVXL840 ONLY

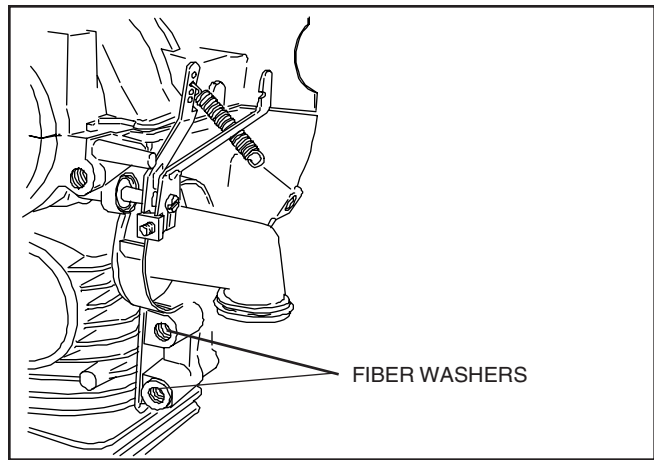
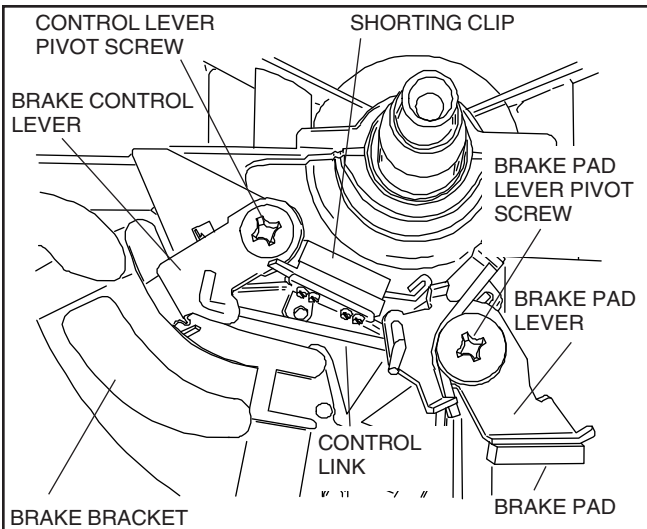

Place one (1) fiber washer on each carburetor post before attaching the carburetor to the cylinder block.

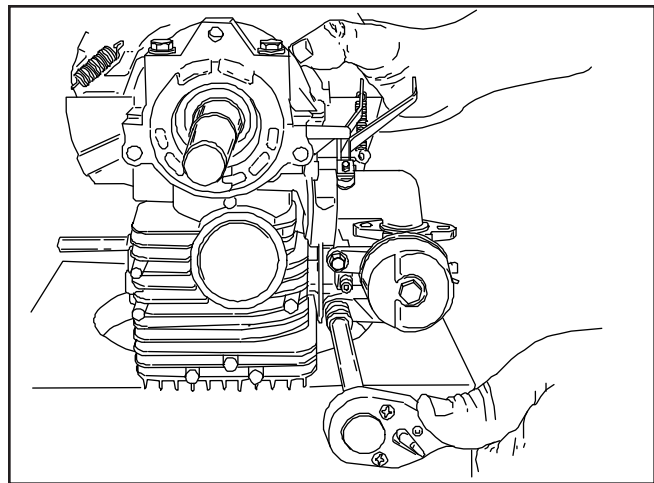
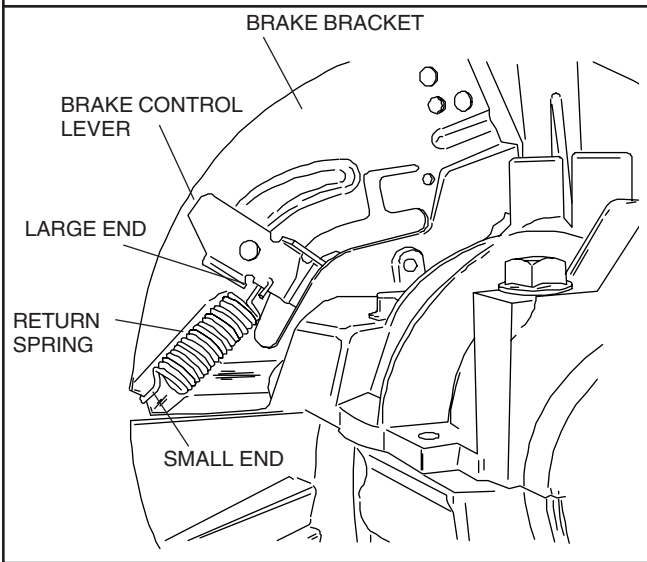

Assemble the carburetor so that the bowl of the carburetor faces the PTO end of the engine.

Assemble the brake assembly as shown. Only on TVS\TVXL840 models.

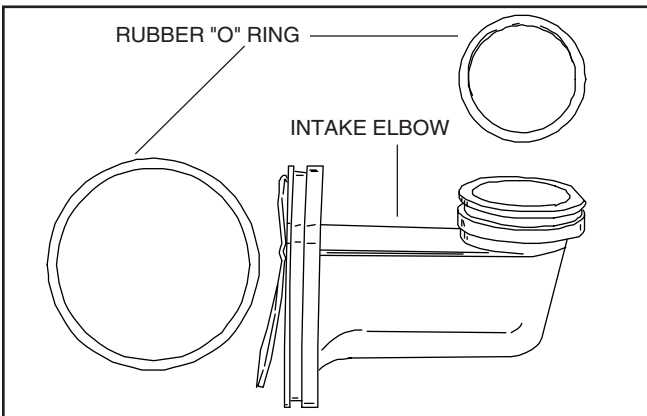

TVS/TVXL840 Models. To insure proper sealing of the intake elbow to the carburetor and the cylinder, replace the rubber "O" rings on the intake elbow with the proper replacement parts.

NOTE: TO PREVENT "O" RING DAMAGE, ALWAYS LUBRICATE THEM WITH OIL ON ASSEMBLY.

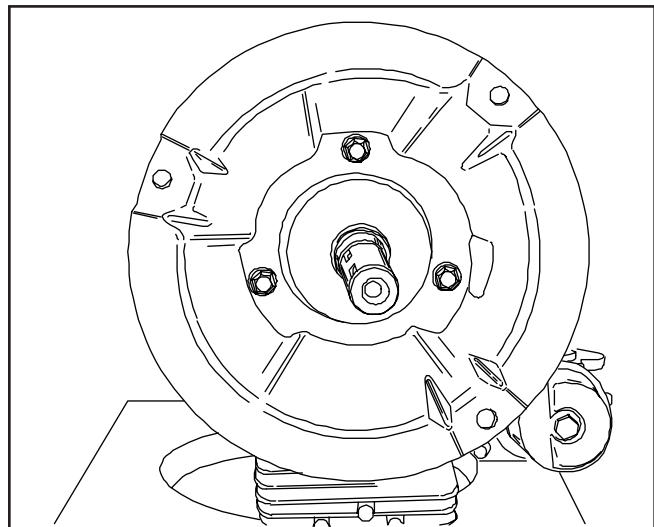

Position the PTO mounting adapter so that the holes line up. You may need to use a rawhide mallet to tap the adapter into place. RTV sealant is used in production on these three mounting screws; be sure to remove all old RTV from screws and mounting holes. New RTV should be placed on screws when reassembling to avoid any porosity leaks.

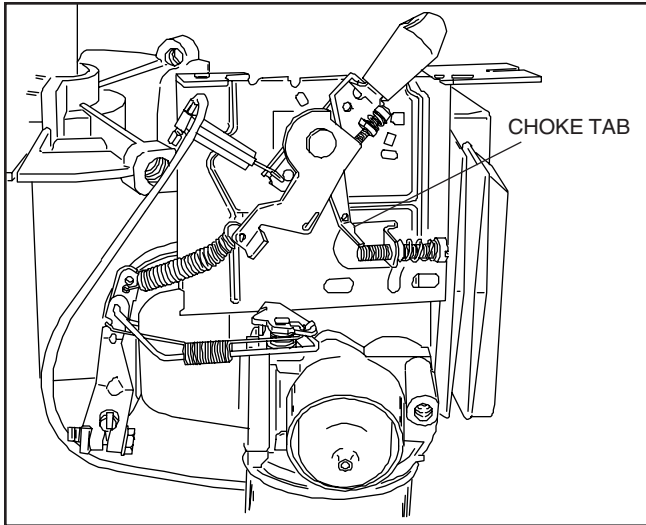

TVS/TVXL840 - Attach the governor linkage to the speed control bracket and carburetor as shown.

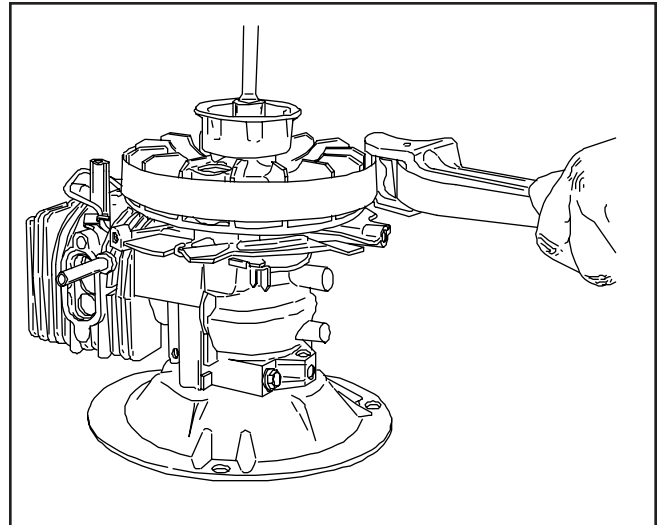

Reposition the flywheel key, starter cup, washer and flywheel nut. Hold the flywheel with the strap wrench #670305, and torque the flywheel nut to specifications.

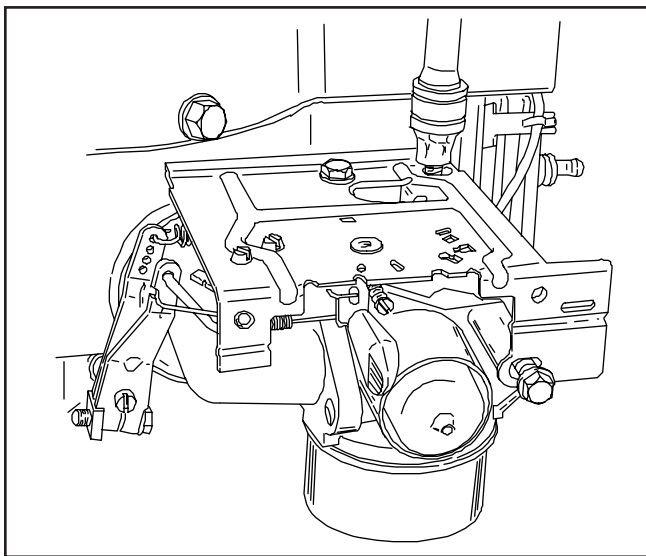

TVS/TVXL840 - Reposition the speed control bracket.

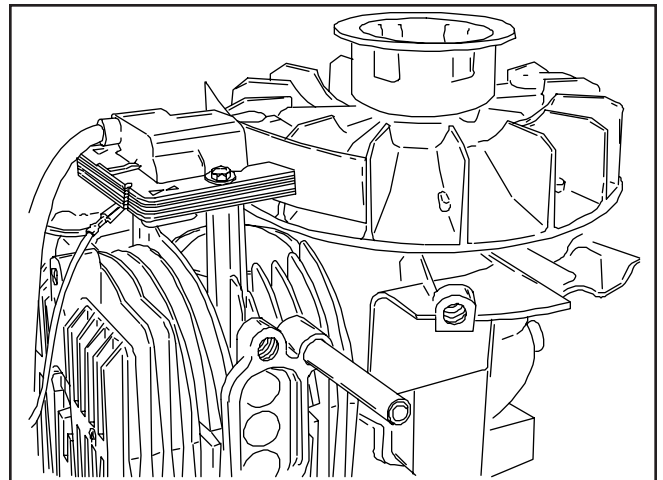

Reattach the solid state module to the engine. Set the air gap between the flywheel and the module laminations at .0125" using Tecumseh air gap gauge #670297. Rotate the flywheel to assure that the flywheel does not strike solid state module.

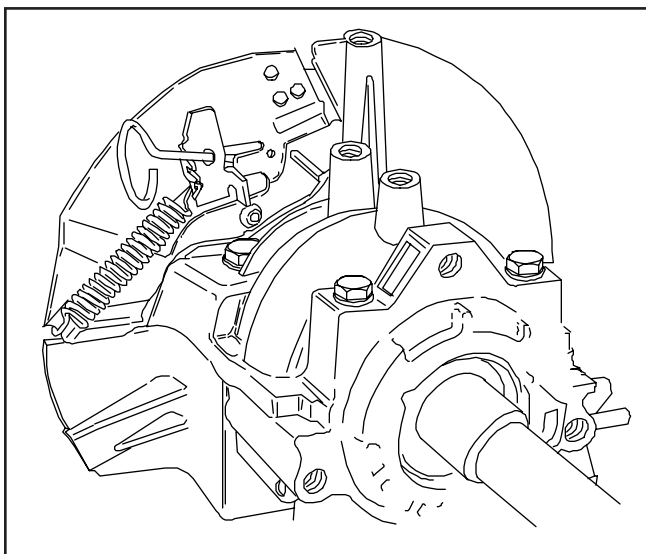

Before repositioning the flywheel be sure to place the brake in the disengaged position. Pull the brake lever away from the return spring as far as it will go. Then place the alignment pin in the hole in the lever so it catches on the shroud.

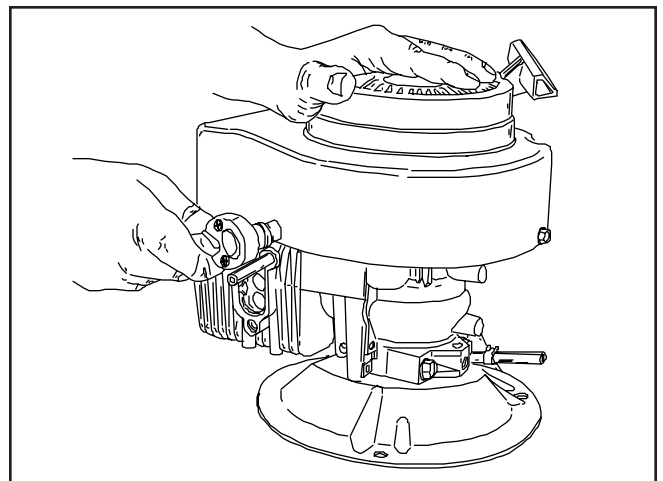

Reinstall the blower housing and rewind assembly.

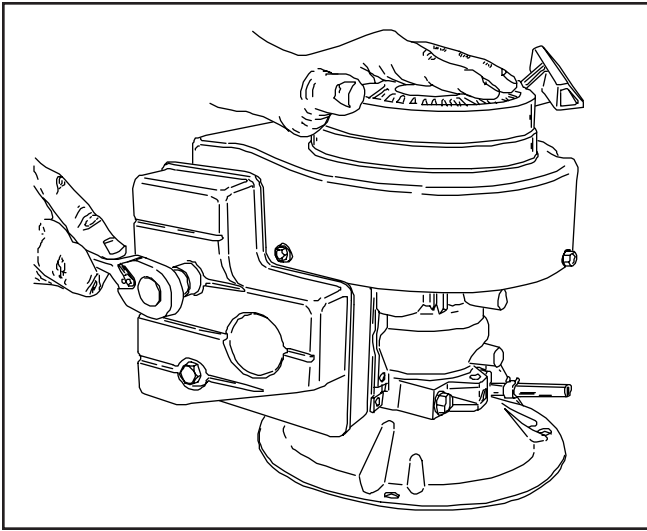

Reposition the gasket and muffler.

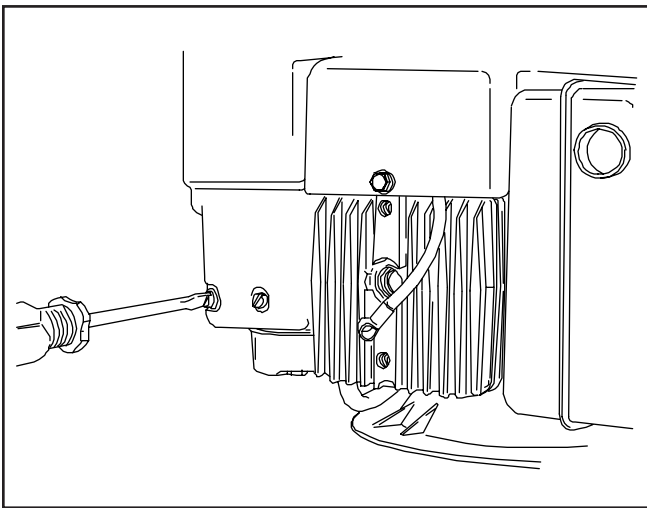

Reassemble the air cleaner components and assemble the air cleaner to the carburetor. These screws require red Loctite #271 to assure retention.

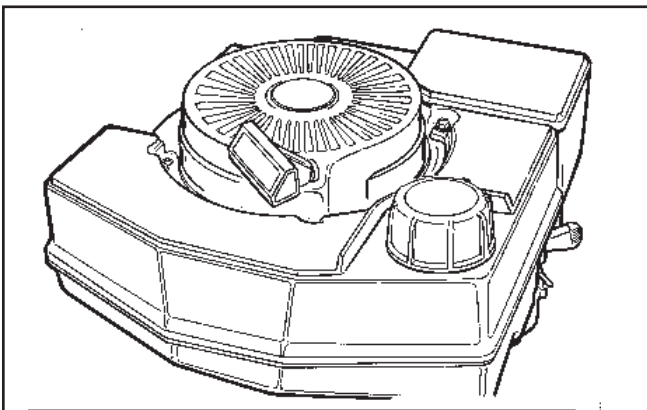

Install the fuel tank and connect the fuel line. Fill the tank with a fuel/oil mixture of 50:1.

NOTE: If the engine was rebuilt, use double the mixture of oil for the first gallon of fuel.

Install the correct spark plug and reconnect the high tension lead.

NOTE: On Snow King® models the fuel tank is supplied by the O.E.M.'s.

TORQUE SPECIFICATIONS

	FOOT POUNDS	INCH POUNDS	Nm
CRANK CASE to CYLINDER	10 - 17	120 - 204	13.5 - 22.9
GOVERNOR LEVER to SHAFT		4 - 8	.5 - .9
GOVERNOR SHAFT BOLT/NUT		30 - 50	.5 - 6.2
CARBURETOR to CYLINDER (TVS/TVXL840)	10 - 10.5	120 - 150	13.4 - 16.8
CARBURETOR to CYLINDER (HXL/HSK845/850)	3.4 - 5.4	40 - 65	4.5 - 7.3
SPEED CONTROL BRACKET to CYLINDER (TVS/TVXL840)		35 - 50	3.9 - 5.6
FLYWHEEL NUT	30 - 33.3	360 - 400	40.3 - 44.8
IGNITION COIL to CYLINDER		30 - 40	3.4 - 5.6
SPARK PLUG	16 - 20	192 - 240	21.5 - 26.9
MUFFLER to CYLINDER	8.3 - 10	100 - 120	12 - 13.4
ADAPTER PLATE to CYLINDER	13 - 18	156 - 216	17.5 - 24.2
BLOWER HOUSING to CYLINDER	7.5 - 10	90 - 120	10.8 - 13.4
FUEL TANK to BLOWER HOUSING (TVS/TVXL840)		25 - 46	2.8 - 5.2
COMPLIANCE BRACKET to CRANKCASE		30 - 40	3.4 - 4.5
MUFFLER GUARD to BLOWER HOUSING		20 - 30	2.2 - 3.4
STARTER		15 - 25	1.7 - 2.8
AIR CLEANER CANISTER HEX NUT		14 - 20	1.6 - 2.2
STUD to AIR CLEANER ELBOW		36 - 60	4.0 - 6.7
AIR CLEANER ELBOW to CARBURETOR		20 - 30	2.2 - 3.4
AIR CLEANER WING NUT		10 - 20	1.1 - 2.2
AIR CLEANER (PLASTIC) to CARBURETOR		6 - 8	.7 - .9
AIR CLEANER BRACKET TO CARBURETOR		15 - 25	1.7 - 2.8
AIR BAFFLE TO CARBURETOR		30 - 50	3.4 - 5.6
SPEED CONTROL BRACKET TO CYLINDER (HXL/HSK845/850)		20 - 35	2.2 - 3.9
ELECTRIC STARTER TO CYLINDER	5.4 - 6.3	65 - 75	7.3 - 8.4
AIR CLEANER SUPPORT BRACKET TO ELBOW	10 - 12.5	120 - 150	13.4 - 16.8

"Torque specifications listed on this page should not be confused with the torque value observed on engines which have been run. Torque relaxation occurs on all engines from thermal expansion and contraction. The torque specification take relaxation into account so a sufficient clamping force exists after an engine has been run."

NOTE: Torque is below 5 Ft/LBS. will not be listed. These should only be done with a Inch/Lb. torque wrench.

ENGINE SPECIFICATIONS

	TVS840 INCHES	TVXL840 INCHES	HSK/HXL840-850 INCHES
BORE	2.437 in. 2.438 in. (61.9 mm)	2.437 in. 2.438 in. (61.9 mm)	2.437 in. 2.438 in. (61.9 mm)
STROKE	1.812 (46 mm)	1.812 (46 mm)	1.812 (46 mm)
CUBIC INCH DISPLACEMENT	8.46 (139 cc)	8.46 (139 cc)	8.46 (139 cc)
SPARK PLUG GAP	.030 (.76 mm)	.030 (.76 mm)	.030 (.76 mm)
PISTON RING END GAP	.007 (18 mm) .017 (43 mm)	.007 (18 mm) .017 (43 mm)	.007 (18 mm) .017 (43 mm)
PISTON DIAMETER	2.4320 (61.77 mm) 2.4326 (61.79 mm)	2.4320 (61.77 mm) 2.4326 (61.79 mm)	2.4320 (61.77 mm) 2.4326 (61.79 mm)
PISTON RING GROOVE WIDTH	TOP .0645 (1.64 mm) .0655 (1.66 mm)	Half Keystone Ring	Half Keystone Ring
	BOTTOM .0645 (1.64 mm) .0655 (1.66 mm)	.0645 (1.64 mm) .0655 (1.66 mm)	.0645 (1.64 mm) .0655 (1.66 mm)
PISTON RING WIDTH	TOP .0615 (1.56 mm) .0625 (1.59 mm)	Half Keystone Ring	Half Keystone Ring
	BOTTOM .0615 (1.56 mm) .0625 (1.59 mm)	.0615 (1.56 mm) .0625 (1.59 mm)	.0615 (1.56 mm) .0625 (1.59 mm)
CRANK PIN JOURNAL DIAMETER	.9710 (24.98 mm) .9715 (24.68 mm)	.9710 (24.66 mm) .9715 (24.68 mm)	.9710 (24.66 mm) .9715 (24.68 mm)
CRANKSHAFT P.T.O. SIDE MAIN BEARING DIAMETER	.9833 (24.98 mm) .9838 (24.99 mm)	.9833 (24.98 mm) .9838 (24.99 mm)	.9833 (24.98 mm) .9838 (24.99 mm)
CRANKSHAFT MAGNETO SIDE MAIN BEARING DIAMETER	.7864 (19.98 mm) .7869 (19.99 mm)	.7864 (19.98 mm) .7869 (19.99 mm)	.7864 (19.98 mm) .7869 (19.99 mm)
CRANKSHAFT END PLAY	.0004 (.01 mm) .0244 (.62 mm)	.0004 (.01 mm) .0244 (.62 mm)	.0004 (.01 mm) .0244 (.62 mm)

NOTE: SPECIFICATIONS ARE IN INCHES
() ARE FOR METRIC DIMENSIONS

TRAINING AIDS AND TOOLS

VIDEO PROGRAMS

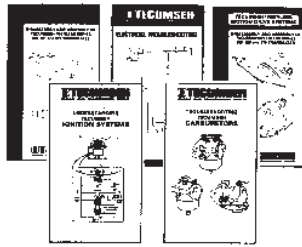

695015

Carburetor Troubleshooting. Covers identification of carburetors used on Tecumseh engines and how to troubleshoot and repair them. VHS only.

695059

Understanding Tecumseh Ignition Systems. A basic program designed to give the small engine technician first hand knowledge of Tecumseh ignition systems so the technician can understand the system and perform repairs to it. VHS only.

695148

Teardown and reassembly of the 900 series transaxles. This video will show a complete step-by-step procedure for teardown and reassembly of the 900, 910 and 920 series transaxles.

695185

Electrical Troubleshooting. This video training program will assist the small engine technician in the proper procedures for troubleshooting electrical systems on outdoor power equipment.

695285

An in-depth look at the 800 series transaxles. Detailing the teardown and reassembly procedures for the 800, 801 and 820 transaxles.

SPECIAL BOOKLETS

INSTRUCTIONAL GUIDE

692738

Assists in the use and understanding of the Tecumseh Master Parts Manual. Illustrates time saving features incorporated into the manual. Explains new carburetor parts breakdown format.

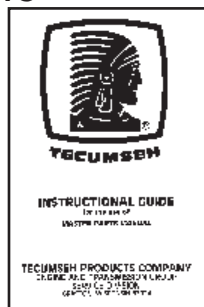

4-CYCLE ENGINE FAILURE ANALYSIS

695590

This booklet is designed as a tool for the average technician to correctly assess the cause of failure.

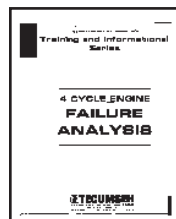

ELECTRICAL TROUBLESHOOTING BOOKLET

693505A

This booklet contains schematic drawings of Tecumseh direct current and alternating current systems and how to check them when problems occur.

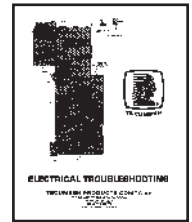

CARBURETOR TROUBLESHOOTING BOOKLET

695907

This booklet is designed as a quick reference to carburetion problems and related repair procedures.

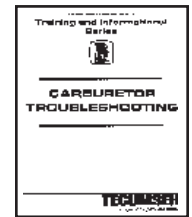

IGNITION SYSTEMS TROUBLESHOOTING BOOKLET

694903

This booklet contains information on the identification, possible problems and related repair procedures of Tecumseh Ignition Systems.

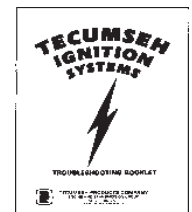

QUICK REFERENCE CHART BOOKLET

695933

This booklet contains the quick reference information found on Tecumseh wall charts.

This booklet is designed to be used as a work bench quick reference guide when servicing Tecumseh engines and motion drive systems.

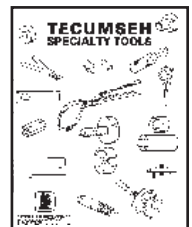

SPECIAL TOOLS BOOKLET

694862

This booklet depicts all specialty tools offered by Tecumseh which can be used on 2 and 4 cycle engines and Peerless units.



TESTER BOOKLETS

694529

Test procedures for Tecumseh electrical components using Graham-Lee Tester 31-SM or 31-SMX-H.



694530

Test procedures for Tecumseh electrical components using Merco-O-Tronic Tester 9800. (Tests are similar for 98, 98A and 79.)



TOOLS

TOOL KIT 670195B

Kit contains tools for 2 and 4 cycle engines.

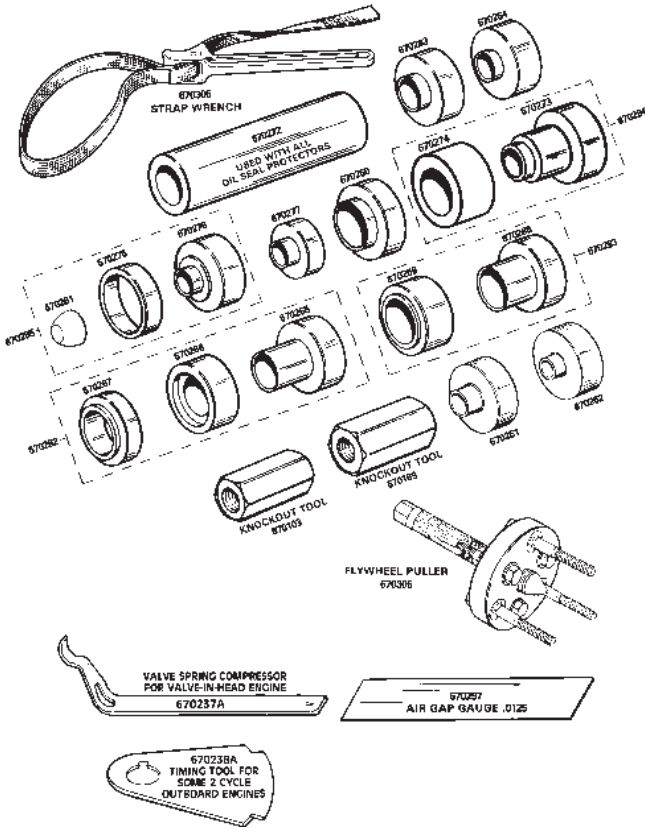

No. 670298 - Aligning Pin

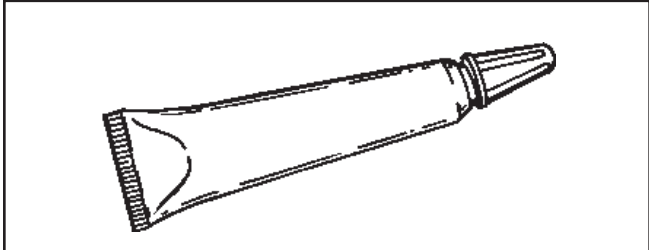
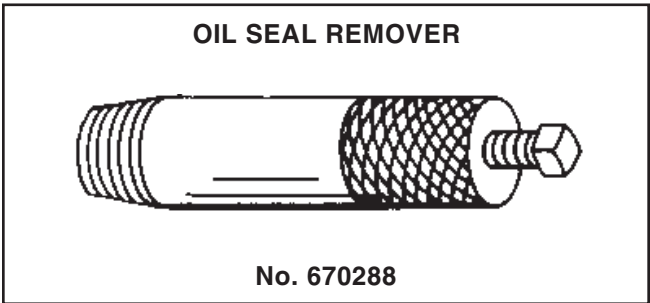
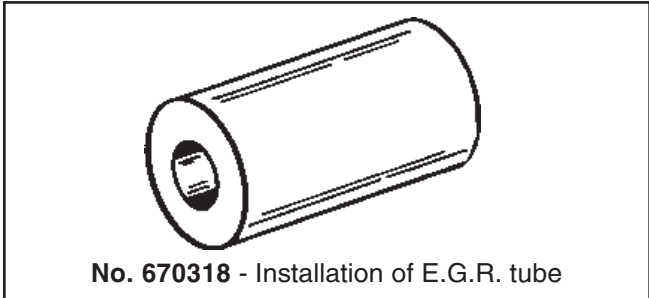

Loctite Gasket Sealant Eliminator No. 515 will be sold by Tecumseh under the part number 510334.

