

OWNER'S MANUAL

WET TILE SAW 7"

Model: CTC705



Scan for a
Digital Copy of the
Owner's Manual

CAUTION: Read all safety and operating instructions before using this equipment.
This manual **MUST** accompany the equipment at all times.

REDEFINING
JOBSITE MUSCLE™

CTC705 saws manufactured by Norton Clipper are warranted against defects in workmanship or materials for a period of one (1) year from the original purchase date from Norton Clipper when used in commercial, institutional, rental, or professional use.

To activate your warranty for all Norton Clipper products visit the **Product Registration** page on the website and register your machine.

The responsibility of Norton Clipper under this warranty is limited to replacement or repair of defective parts at a point designated by it, of such part as shall appear to us upon inspection at such point, to have been defective in material or workmanship, with expense for transportation borne by the customer.

In no event shall Norton Clipper be liable for consequential or incidental damages arising out of the failure of any product to operate properly.

Integral units such as **gasoline engines, electric motors, batteries, tires, transmissions, etc.**, are excluded from this warranty and are subject to the prime manufacturer's warranty. This warranty is in lieu of all other warranties, expressed or implied, and all such other warranties are hereby disclaimed.

Important: Before placing equipment in operation, record the following information:

UPC #: <i>(starts with 701846-xxxxx)</i>	MODEL #:
<input type="text"/>	<input type="text"/>
SERIAL #:	PURCHASE DATE:
<input type="text"/>	<input type="text"/>
PURCHASED FROM:	ADDRESS/CITY/STATE/ZIP:
<input type="text"/>	<input type="text"/>

Before using this equipment, make sure that the person using it has read and understands the instructions in this Owner's Manual.









**PRODUCT
REGISTRATION**

Scan To
Activate Your
Warranty

Table of Contents	1
Safety Precautions	3-7
Dust and Silica Warning	5
Machine Lifting Points	6
SPECIFICATIONS & Features	8-9
CTC705 Specifications	8
Optional Accessories	9
Unpacking, Assembly, & Setup	10-12
Blade Guard Blade Assembly	10-11
Folding Stand Installation	11
Blade Installation	12
Water Pump Installation.....	12
Water Pump Safety Precautions.....	12
Electrical.....	13-16
Electrical Specifications	13
Extension Cords	13
Electrical Supply	13
General Electrical Trouble Shooting	14-16
Wiring Diagram.....	14
Operation.....	17-19
Saw Maintenance & Trouble Shooting.....	20-30
Parts Break.....	31-33
Parts Ordering	31
CTC705 Exploded View.....	32
CTC Service Parts Listing.....	33









Important warnings and pieces of advice are indicated on the machine with icons.

HAZARD ICONS

	<p>Fuel (gasoline) is extremely flammable, and its vapors can explode if ignited. Store gasoline only in approved containers, in well-ventilated, unoccupied approved areas, and away from sparks or flames. Do not fill the fuel tank while the engine is hot or running. Do not start the engine near spilled fuel. Never use the fuel as a cleaning agent</p>
	<p>Hot surface! Do not touch. Engine components can get extremely hot from operation. To prevent burns, do not touch the engine or related parts while the engine is running or immediately after it is turned off. Never operate the engine with any heat shields or guards removed.</p>
	<p>Keep all guards in place when operating any piece of equipment.</p>
	<p>Moving parts can crush and cut. Keep hands, feet, hair, and loose clothing away from all rotating parts.</p>
	<p>Lethal Exhaust Gas: use only in well ventilated areas. Engine exhaust gases contain poisonous carbon monoxide, which is odorless, colorless, and can cause death if inhaled. Avoid inhaling exhaust fumes, and never run the engine in a closed building or confined area.</p>
	<p>Never tamper with the governor components of settings to increase the maximum speed. Severe personal injury and damage to the engine or equipment can result if operated at speed above maximum. Always obey the maximum speed rating of blade.</p>
	<p>Warning alert symbol. DO NOT LIFT THE SAW BY THE HANDLEBARS OR CUTTING TABLE.</p>

Important warnings and pieces of advice are indicated on the machine with icons.

SAFETY ICONS

 <p>Read operator's instructions.</p>	 <p>Read OSHA and ANSI B7.1. Visit the industry safety page: www.safety.UAMA.org</p>
 <p>Eye protection must be worn.</p>	 <p>Ear protection must be worn.</p>
 <p>Protect your lungs against dust.</p>	 <p>Hand protection must be worn.</p>
 <p>Rotation direction of the blade.</p>	  <p>Pump On Pump Off</p>

DUST AND SILICA WARNING

Grinding/cutting/drilling of masonry, concrete, metal, and other materials can generate dust, mists and fumes containing chemicals known to cause serious or fatal injury or illness, such as respiratory disease, cancer, birth defects or other reproductive harm. If you are unfamiliar with the risks associated with the particular process and/or material being cut or the composition of the tool being used, review the material safety data sheet and/or consult your employer, the material manufacturer/supplier, governmental agencies such as OSHA and NIOSH and other sources on hazardous materials and make certain to comply with all product warnings and instructions for the safe and effective use of the material being cut. California and some other authorities, for instance, have published lists of substances known to cause cancer, reproductive toxicity, or other harmful effects.

Control dust, mist, and fumes at the source where possible. In this regard use good work practices and follow the recommendations of the manufacturer/supplier, OSHA/NIOSH, and occupational and trade associations. Water should be used for dust suppression when wet cutting is feasible. When the hazards from inhalation of dust, mists and fumes cannot be eliminated through engineering controls such as vacuum and/or water mist, the operator and any bystanders should always wear a respirator approved by NIOSH/MSHA for the material being cut.

CALIFORNIA PROPOSITION 65 MESSAGE

Some dust created by power sanding, sawing, grinding, drilling, and other construction activities contain chemicals known (to the State of California) to cause cancer, birth defects or other reproductive harm. Some examples of these chemicals are:

- Lead, from lead-based paints
- Crystalline silica, from bricks and cement and other masonry products
- Arsenic and chromium, from chemically treated lumber

For Addition Information Consult the Following Sources:

<http://www.osha.gov/dsg/topics/silicacrystalline/index.html>

<http://www.cdc.gov/niosh/consilic.html>

<http://oehha.ca.gov/prop65/law/P65law72003.html>

<http://www.dir.ca.gov/Title8/sub4.html>

Use Approved:



The engine exhaust from this product contains chemicals known to the State of California to cause cancer, birth defects or other reproductive harm

108934



Eye Protection



Hearing Protection



Respiratory Protection



Head Protection

1. Before mounting any blade on the saw, the blade should be inspected for any damage which might have occurred during shipment, handling, or previous use.
2. The blade collars and arbors should be cleaned and examined for damage before mounting the blade.
3. The blade must be properly fitted over the arbor with the relief side of the collars facing the blade.
4. The blade shaft nut must be tightened securely against the outside blade shaft collar.
5. The blade must be operated within the specified maximum operating speed listed on the blade.
6. Fill the water pan with water.
7. The blade guard must be in place with the nose guard down and locked when the saw is running.
8. The operator should wear safety glasses and any other appropriate safety equipment.
9. When starting the saw, the operator should stand away and to the side of the blade.
10. If for any reason the saw should stall in the cut, remove the material from the blade. Check the outside blade shaft collar and nut for tightness. Inspect the blade for damage before restarting the saw. Use caution when resuming a cut. Be certain that the blade is in alignment with the previous cut.
11. Do not force the blade into the cut by pushing the material into the blade too fast.



You Are Responsible For Your Safety!!!

Machine Lifting Points

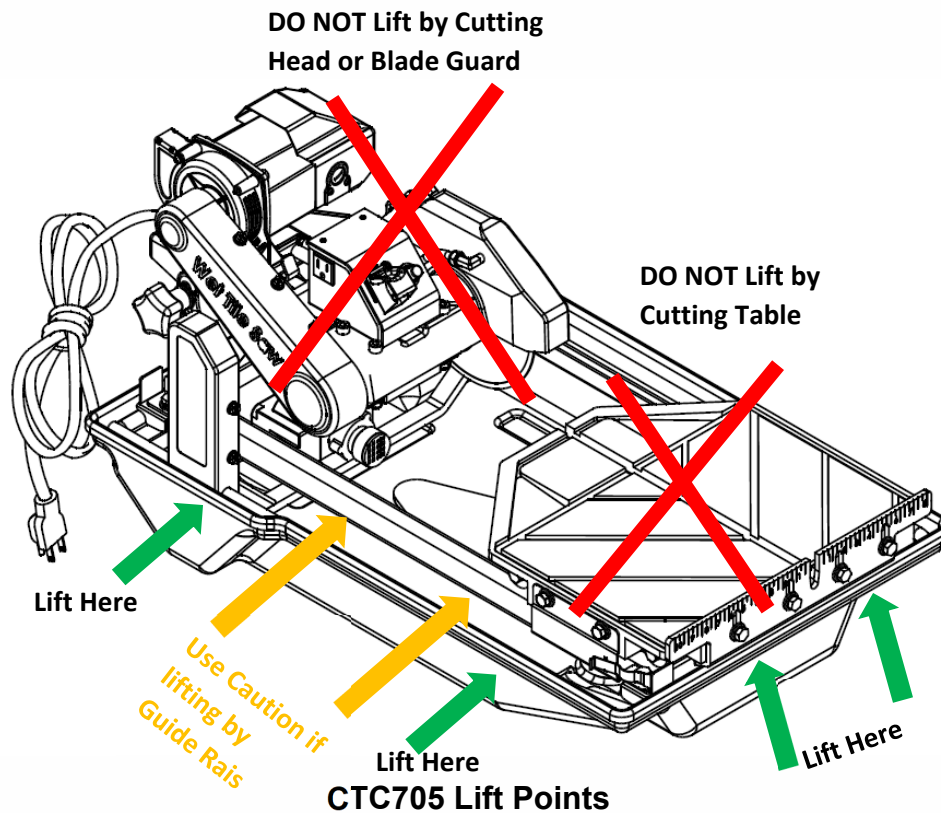

- The best lifting point is from the underside of the lip of the water pan which is highlighted with **GREEN** arrows on both sides of the machine or at the front and back.
- The CTC705 Tile Saw can easily be removed from the water pan so take care when lifting by the Guide Rails highlighted with **ORANGE** arrows
- DO NOT lift by the Cutting Table
- DO NOT lift by the Cutting Head
- DO NOT lift by the Blade Guard
- DO NOT move or lift by pulling on the power cord
- Always verify that the power is disconnected from the CTC705 before moving or lifting.

1. A Powerful 1 HP brush motor makes cutting easier and quicker.
2. The Automatic Thermal Overload Protection system protects your saw from power surges and overheating.
3. The high fiber plastic water tray withstands even the toughest jobs, yet it is extremely easy to remove and install.
4. The saw is encased in a sturdy, durable steel frame, optional equipped with folding stands with work bench for easier operation.
5. Adjustable guide rails permit the user to align the saw during installation.
6. The cutting alignment will not be affected by any water tray maintenance.
7. The cutting table can be secured in place by tightening the knob screw on the L-shaped transport retention plate.
8. The cutting rip guide is designed for both 90° square cutting and 45° angle cutting.
9. The 705's blade capacity is 6"~7" which provides a variety of blade usage.
10. Straight cuts can extend out to 17" in length and diagonal cut up to 12" in length.

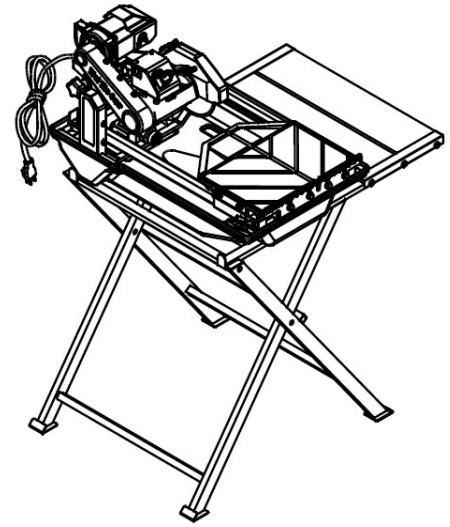





**Optional
Saw Stand with Work Bench**

CTC705	
Maximum Cutting Length (mm)	17" (431)
Maximum Diagonal Cutting (mm)	12" (305)
Max Blade Size (mm)	7" (177)
Max. Depth of Cut (mm)	2-1/4" (57)
Blade RPM	6,000 RPM
Horsepower	1 HP (075kW) 115 volt
Motor Engine Type	Carbon Brush
Electrical (Volts/Cycles/Phase)	115v/60Hz/1
Dimensions (mm)	30" (762) L x 19-3/4" (502) W x 17-1/2" (445) H
Cart Table size (mm)	14-1/4" (362) L x 15" (381) W
Pan Size (mm)	30" (762)
Weight (Kg.)	43 (19.5)

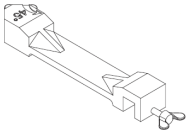
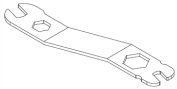
CTC705 Specifications

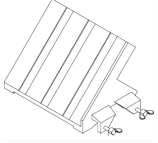
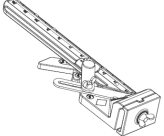
Optional Accessories

UPC	Description	QTY	Type	Image
70184682710	RIP GUIDE45/90 CTC/YTM7	1	S	
70184680905	WRENCH UNIVERSAL YTM1015	1	S	
Optional Accessories:				
70184643045	STAND WITH WORKTABLE	OPT	S	
70184680897	MITER BLOCK (For Miter Cutting Includes Mounting Hardware)	OPT	S	
70184680907	GUIDE ADJUSTABLE ANGLE GUIDE (Includes Mounting Hardware)	OPT	S	
70184633009	GFCI PLUG NEMA 5-15P x NEMA 5-15R (Connect to Power Supply then attach machine or extension cord to GFCI for additional operator protection)	OPT	S	

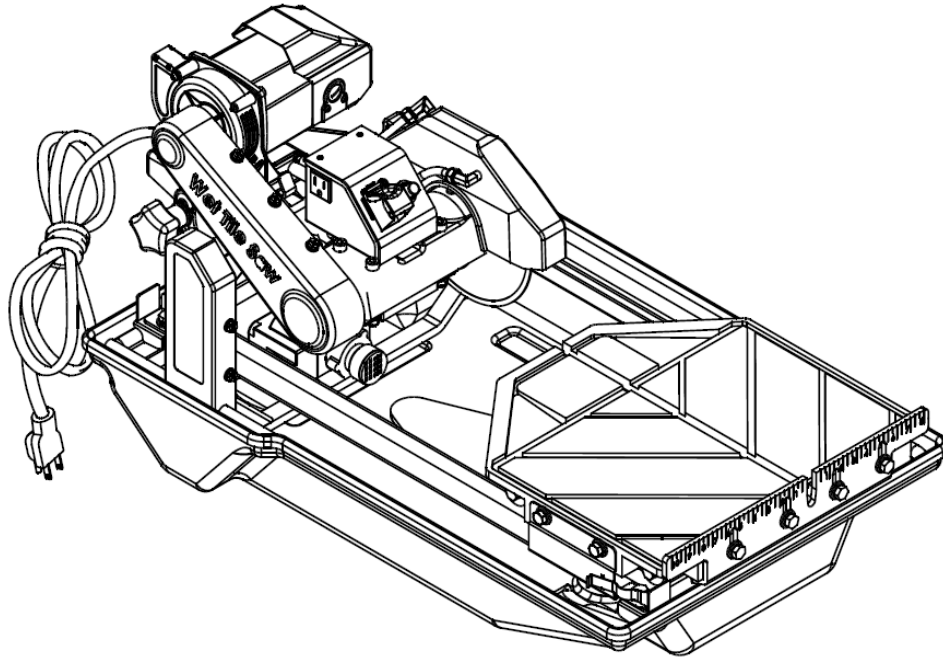

Open the container, carefully lift the saw by the saw frame handles and place it on a flat, level working area. Be certain that you have the following items before you discard the container.

- Saw
- Universal Wrench
- Polypropylene Water Tray
- Water Pump
- Ø7" Saw Blade
- Miter Block
- 45° / 90° Rip Guide
- Owner's Manual

Blade Guard Assembly

1. Remove the Blade Guard (1) and saw Blade package from the accessory box.
2. Lift the cutting head (2) from the insert style-foam that is designed to re-enforce strength to the box.
3. Slide the cutting head through the rear support post's shaft as shown in the lower diagram and screw on the adjustment knob.
4. Slide the Blade Guard into the hex bolt (3) located at the rear of right side of the Electrical Control Box (5) and fasten tightly using the knob screw (4).
5. Place the Ø7" blade onto the shaft, make sure that the directional arrow is pointing in the direction of the shaft rotation. Lift up the Blade Guard, then fasten the blade tightly using the outer Flange and Lock nut.

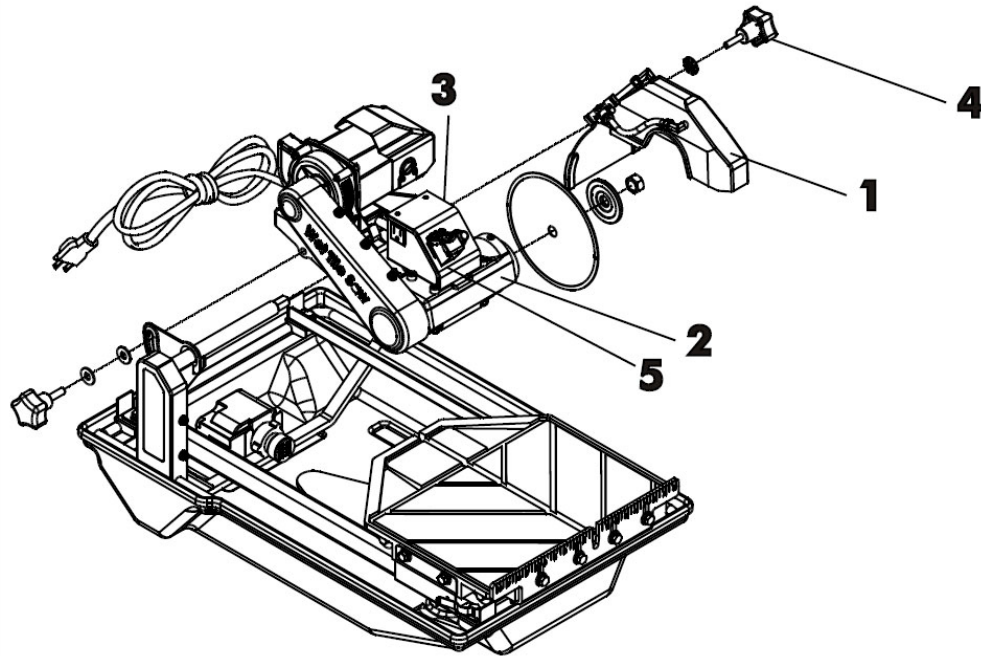

Blade Guard Assembly

Folding Stand Assembly

1. The optional Folding Stand with Worktable ships ready to use with no assembly needed.
2. Table Remove the folding stand from its box.
3. Swing the working bench up-right. Open the two legs and place the work bench on top of the folding stand.
4. After the saw stand is completely assembled, place the saw on top of the saw stand as shown in the image to the right.

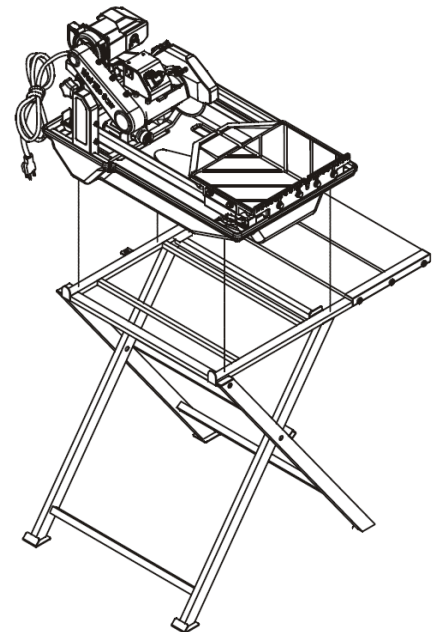

Blade Installation

1. Raise the blade guard to the highest position and tighten the blade guard adjustment knob.
2. Remove the blade shaft nut and outer flange.
3. Verify the direction of rotation of the Diamond Blade and match it to the CTC705. NOTE: The Blade Shaft of the CTC705 will rotate Counterclockwise when looking at the blade collars.
4. Place the blade onto the shaft making sure that the directional arrows are pointing in the direction of the shaft rotation.
5. After making sure that the blade is firmly placed against the inner flange, secure it into place with the outer flange and blade shaft nut.
With one hand hold the blade tightly and tighten the blade shaft nut with your free hand. Make certain that the nut is firmly tightened with the wrench provided, but do not over-tighten!
6. Lower the blade guard and tighten the adjustment knob.

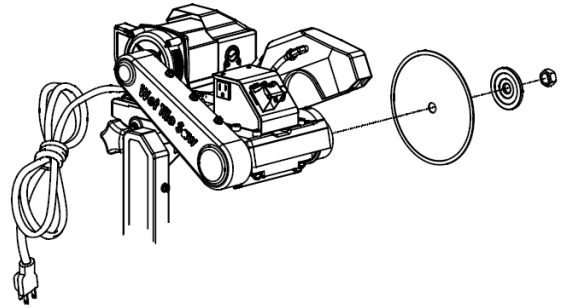

Warning: Only use the Ø6"~Ø7" blade for this saw. Setting smaller size of diamond blade may grab the material being cut, causing damage and possibly injury.

Water Pump Installation

1. Remove the water pump from the box.
2. Place the pump into the middle of the water tray along its side so that the water outlet is positioned horizontally. Connect the water hose from the blade guard to the pump and plug the power cord into the 3-prong receptacle.
3. Fill the water tray so that the water intake is fully immersed.

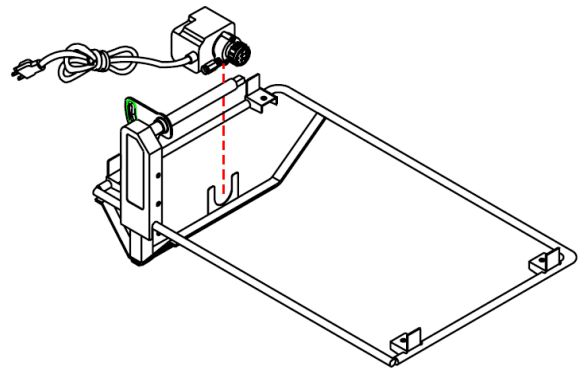

Water Pump Safety Precautions

Never operate pump without water on tray. Fill the water so that water intake is full.

- Be sure to connect the plug to a properly grounded receptacle to reduce risk of shock.
- Disconnect pump before attempting to use pump, to unclog or service the pump in any way.
- Be sure to support the pump during installation to prevent pump failure or damage.

CTC70 Electrical

Motor Specifications:

Voltage: 115-volt
 Cycles: 60Hz
 Amperage: 15 Amp
 Horsepower: 1 HP
 Watts: 735 watts
 Motor RPM: 18,000 RPM

Electrical Motor Specifications

Table 3. Extension Cord Chart	
Wire Gauge	115V Max Length
12 AWG	25' (7.6 m)
10 AWG	50' (15.2 m)
8 AWG	75' (22.8 m)

Recommendations:

- It is recommended that a 15 AMP CIRCUIT be used while operating this saw, for best performance use a 20 AMP CIRCUIT. This will prevent any loss of power or interruption.
- Always plug saw as close as possible to the power source while operating. This will allow you to receive optimum electricity.

Extension Cords:

Most motor trouble is the result of too small gauge or too long of extension cord. **Cords must be one piece and as short as possible.** Cords should be no longer than shown on Table 3: Extension Cord Maximum Length Chart (see above). Norton Construction Products is not responsible for damage to motors due to the use of extension cords that are too small or too long.

Electrical Supply:

The CTC705 can only be used on a 115-volt 60 Hz 1 Phase circuit with a minimum of a 15-amp breaker, for best performance use a 20-amp breaker. **Before connecting the CTC705 to the electrical supply, make sure the voltage is 115v. Connecting the CTC705 to voltages higher than may result in motor damage and is not covered under any warranty.**

Generator:

Using the machine with a generator that is less than the recommend output can result in motor damage and is not covered under warranty. Only use with a generator that is capable of continuous put of 4,000 w (4kW) at 20 amps or greater.

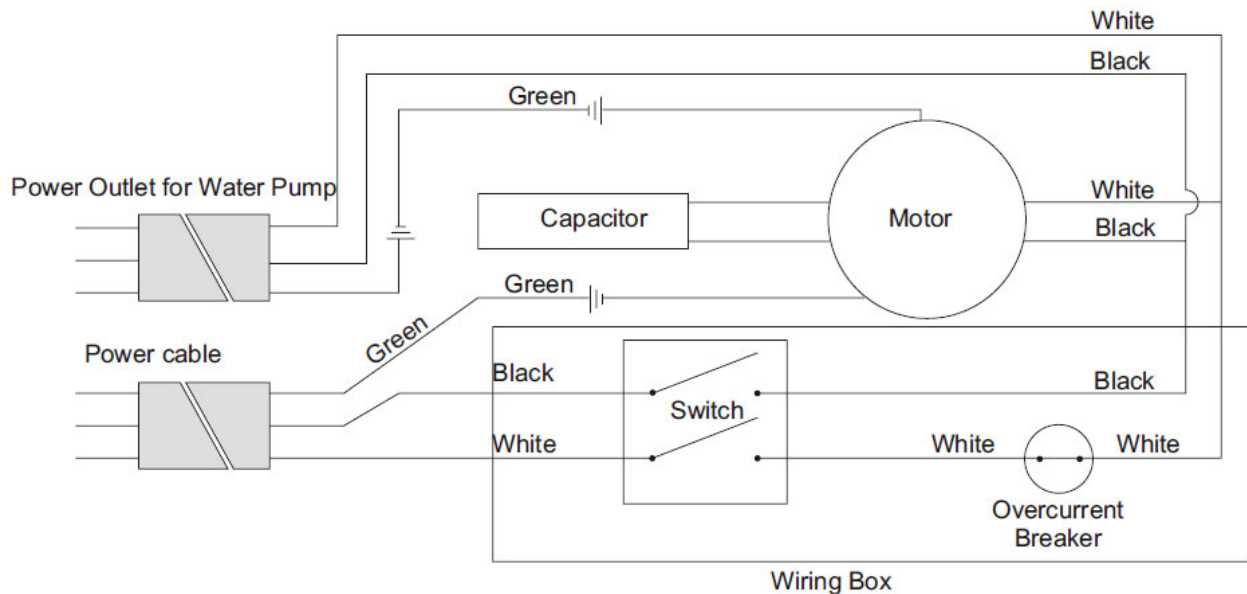

CTC705 Wiring Diagram

Circuit Breaker During Start Up or Not Cutting:

- Verify that the power supply voltage matches the motor name plate voltage
 - ⚠ Failure to run the motor on the proper voltage will damage the motor and is not covered under warranty. Improperly wired motors are not covered under warranty.
- Verify that the circuit breaker is correct for the machine and voltage being used
 - Although the CTC705 can be used on a 15A circuit a 20A is recommend for best performance.
- Verify that the Extension Cord meets the requirements on See: **Extension Cords** page 18
- Have a qualified Electrician verify that the Electrical Connections are correctly made.
- If using a generator, verify that it meets the minimum requirements See: **Generators** on page 18
- Remove the extension cord from the machine and connect the machine directly to the power supply, if the problem disappears the issue is low voltage due to the extension cord being too thin of gauge, too long, spliced together, or a combination of all.
- Change power source if the problem disappears the issue is with the original power source (Low voltage, low amperage breaker, or damage breaker)

Most motor issues are due to low voltage, under rated circuit breakers, and or extension cord issues.

Circuit Breaker Trips while cutting: - This is an issue with the Blade or Cutting Method being used or too long/thin extension cord or extremely low voltage at the machine.

- Verify that the Blade Being used is correct for the material being cut
- Verify that the Blade is properly exposed
- Verify that the Blade is installed properly

- Verify the cutting method. Forcing the Blade into the material is a sign that either the Blade is **NOT** correct for the material being cut or an inexperienced operator. Let the Blade and Machine work for you do not work for the Blade and Machine.
- If cutting hard materials do not use General purpose blades. General purpose blades are designed to cut multiple soft to medium hardness materials and will not perform properly when cutting harder bricks, pavers, or other building materials. In correct blade usage is the number one root cause for motor issues. If you need assistance choosing the correct blade for the material being cut, contact customer service at 1-800-554-8003.
- Verify Extension Cord Length and Gauge See: **Extension Cords** page 18
- Verify voltage at the machine must be 115v

Overload Protector (Thermal) Trips – This is a sign of Low Voltage, Incorrect Blade for Material being cut, or forcing the Blade through the material.

- Verify Voltage at the machine!
- Verify that the Extension Cord meets the requirements on See: **Power Supply** page 18
- Verify the cutting method. Forcing the Blade into the material is a sign that either the Blade is **NOT** correct for the material being cut or an inexperienced operator. Let the Blade and Machine work for you do not work for the Blade and Machine.
- If the Overload Protector trips immediately when the unit is turned on this is a sign of extremely low voltage or damage Overload Protector.
- Clean Motor by blowing out the fan cover with compressed air
- Check the Motor for a damaged
- To reset the Overload Protector (Thermal) let the motor cool down for 5 to 10 minutes and then press the Thermal Overload Protector to reset. The Thermal Overload Protector will not reset until the unit has fully cooled.

Electrical Trouble Shooting

Verify voltage to the motor 115v/60 Hz/1 Phase

2. Verify extension cord See: **Extension Cords** page 18
3. What is the motor doing when switch is turned on (nothing, humming, tries to turn on but shuts off, tripping of circuit breaker) It could be a dirty air filter, a faulty start, or a tripped/damage power supply circuit breaker.

Nothing happens when the power switch is turned on:

- a) No power
- b) Tripped Power Supply Circuit Breaker
- c) Tripped Overload Protector on machine (see: **Overload Protector (Thermal) Tips** page 18.

Humming or strange noises from motor or gear box:

- a) Damage motor or gear box. Most damages are from not using air filters, or not cleaning and replacing dirty air filters
- b) Water in the motor

Tries to turn on but shuts off:

- a) Power supply Circuit Breaker verify if correct see **Power Supply** page 18
- b) Too long or thin extension cord see **Extension Cords** page 18

c) Overload Protector (Thermal) issues see **Overload Protector (Thermal) Tips** page 17.

d) Low voltage at the machine see **Power Supply** page 18

Tripping of Circuit Breaker:

a) If tripping while starting machine

Circuit Breaker issue: weak, damage, to low amperage

b) If tripping while cutting any material:

Incorrect blade for the material being cut.

5. What are you cutting?

6. Wet/dry?

If cutting dry give the blade a chance to cool off and breath. The heat will build up and can affect the performance of the motor as the blade lose tension.

7. What blade is being used?

Use the correct blade for the material being cut.

9. What cutting method is being used. Change cutting methods.

9. May need to go to [Authorized Service Center](#) to diagnose and repair

Operation

The CTC705 tile saw is designed to cut tiles, stones, masonry products, bricks, and pavers up to 18" x 18" x 1-3/4". The CTC705 should always be used wet if dry cutting use only blades designed for dry cutting and follow all OSHA requirements for dry cutting.

1. Read and understand this manual.
2. Follow all includes safety warnings, warnings on the machine.
3. Ensure that all personal around the work area are wearing proper PPE.
4. Place the CTC705 on a flat, clean surface or if using the Optional Folding Stand with Worktable verify that the area is flat and clear of any obstructions (the CTC705 water pan will sit into the pocket on top of the Folding Stand).
5. Verify that the Cutting Table moves freely on the Cutting Table Rails.
6. Verify that the correct blade is being used for the material to be cut.
7. Verify that the Blade is installed correctly. See **Blade Installation** page 16 for details.
8. Verify that the Blade Guard is secured to the CTC705.
9. Inspect the machine for any damage. If the machine is damaged or any parts are missing do not use.
10. Inspect the CTC705 power cord and Water Pump Cord for damage.
11. Fill the water pan with water and verify that the water pump intake is submerged.
12. Connect the CTC705 to the power supply
13. Adjust the cut depth to the required depth and fully tighten the Cutting Head Locking Knob.
14. Place the material on the worktable where the cut is required.
15. Unlock the Cutting Table so that it can roll freely
16. Turn on the CTC705 Power Switch
17. Let the motor run for a minute or two and check the water flow
18. Hold the tile against the Back Stop on the Cutting Tile while keeping all fingers, hands, and body parts away from the blade
19. Slowly move the material into the blade by pushing the Cutting Table towards the blade.
20. Allow the blade to cut into the material and slowly push the material through the blade with an even smooth force all while watch the cut line, water supply, and ensuring all body parts are not in the path of the blade
21. When the blade is approximately 3/8" (10mm) from the end of the material slow the feed speed to reduce chipping.
22. When finished cutting turn off the machine.



Cutting Head Locking Knob

Additional Cutting Features

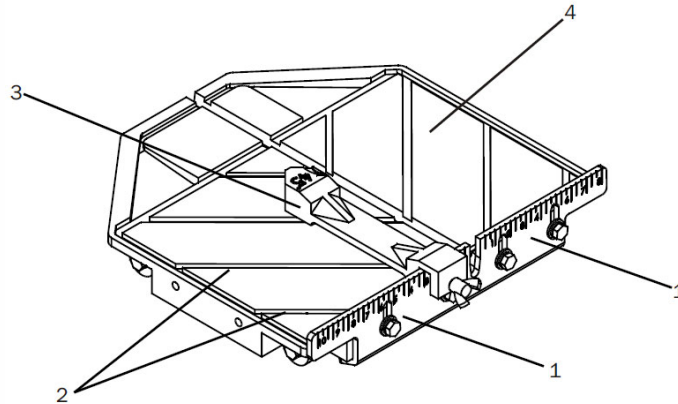

Cutting Table

- The Cutting Table features an adjustable ruler guide (1) enable easy aligning and measuring of cuts. The Ruler Gide can be removed for longer tiles and finetuned to ensure accurate measurements of any tile (loose the attachment screws and move left or right to align the center of the blade with the “0” mark in the Ruler guide then tighten the hardware.
- The Cutting Table also features 45° marks in the form of lines for quick angle cuts.
- The included Guide-A-Cut (3) provides a surface for cutting multiple tiles at the same length by simply lining up the material being cut with the appropriate pre-marked lines (3) on the cutting table. In addition, the wing nut in the Guide-A-Cut can be moved to the opposite end to allow for 45° cutting. See the section “**Guide-A-Cut**” below for additional information.
- The 15”x18” cutting table provides more support during larger cutting jobs.

Guide-A-Cut

1. Set the Guide-A-Cut (3) by positioning it on the desired dimension and tighten the wing nut. Make sure that the rip guide is firmly tightened to avoid slippage. The rip guide can be used for 90° rip cuts and 45° angle cuts from both the left and right side. (Note the straight and 45° angled slits on the bottom of the rip guide.)
2. After the Guide-A-Cut is positioned for the desired cut, place material flat against the rip guide and the measurement rail. For 45° rip cuts, place the corner of material in the open slot of the measurement rail.
3. Simply line up the material being cut with the appropriate pre-marked lines on the cutting table.
4. Now you are ready to make your cut.

Miter Cuts

1. For miter cuts, place the lip of the miter block on the Ruler Guide, with the threaded knobs facing you.
2. Tighten the threaded knobs to secure the miter block in place.
3. Place material onto miter block and you are ready to cut.

Cutting Depth

The recommended cutting depth is to have the bottom of the diamond blade approximately ¼" below the cutting table surface.

The CTC705 is designed with a 1-½" ~1-¾" clearance between the top of the cutting table and the blade trough.

Warning: Only use either Ø6" or Ø7" blades for this saw. Using a smaller size diamond blade may grab the material being cut instead of cutting it, causing damage and possibly injury.

Blade Diameter	Cutting Depth
6"	1-½"
7"	1-¾"

Wet cutting Blades

DO'S

- Inspect blades daily for cracks or uneven wear.
- Always use appropriate blade for material being cut.
- Inspect arbor shaft for uneven wear before mounting blade.
- Always use blades with the correct arbor shaft size.
- Ensure that blade is mounted in the correct direction.
- Secure the blade to the arbor with a wrench.
- Use proper safety equipment when operating the saw.
- Periodically check the blade for cracks or bond fatigue.
- Always have a continuous flow of water on both sides of blade.

DON'TS

- Do not operate the saw without safety guards in position.
- Do not operate the saw with blades larger than 7”.
- Do not cut dry with blades marked "Use Wet".
- Do not exceed manufacturer's recommended maximum RPM.
- Do not force blade into material let blade cut at its own speed.

Dry cutting Blades

DO'S

- In addition to the following, always follow wet recommendations.
- Use appropriate blade for material being cut.
- Inspect segment blades for segment cracking or loss.
- Do not use damaged blades.
- Use proper safety equipment when operating the saw.

DON'TS

- In addition to the following, always follow wet recommendations.
- Do not make long cuts with dry blades--allow them to air cool periodically.
- Do not use the edge or side of blade to cut or grind.
- Do not attempt to cut a radius or curve.
- Do not cut too deep or too fast into the material.

Saw Maintenance	
<i>Maintenance Interval</i>	<i>What to do for maintenance and care</i>
After every use of the machine	Remove dirty water from container. Remove dirt and mud from the bottom of the container. Rinse the immersion pump with fresh water to prevent water pump clogging from residual dirt.
After wet cleaning and before using the machine again	Connect the machine to an electric power outlet equipped with a "GFCI" power breaker. If the safety power breaker cuts off the electrical power supply, do not try to operate the machine but have it checked by an authorized dealer first.
Before not using the machine for a prolonged period of time	Clean and lubricate all movable parts.
After not using the machine for a prolonged period of time	Check that the stand is safely fixed. Check that all screw joints and nuts are fixed. Check that the roller table is in its guides and that it easily moves to and from. With the saw blade removed, switch on the motor for an instant and switch it off again. If the motor does not run, have the machine inspected by a qualified electrician. Check that the immersion pump works properly. Turn on the cooling water tap and switch the machine on. If the pump does not give any water or only a little, switch the machine off at once. Clean the pump or replace if necessary.
Ambient temperature below 32 F (operation in winter)	To prevent the water in the pump and cooling system from freezing, remove the water after using the machine or when there will be a long break. Make sure that the cooling system is entirely drained so that there is no water left inside the pump, water hose and bearing housing!

Trouble Shooting		
<i>Problem</i>	<i>Possible Cause</i>	<i>Solution</i>
Machine does not run when switched on	<ul style="list-style-type: none"> • Power cord not properly fixed/plugged in • Power cord defective • Main power switch defective. • Loose electrical connection inside the electric system. • Motor defective 	<ul style="list-style-type: none"> • Check that the machine is properly connected to the power supply • Have the power cord checked, replace if necessary • Have the main power switch checked and replaced, if necessary, by a qualified electrician. • Have the whole electric system of the machine checked by a qualified • Electrician Have the motor checked and replaced, if necessary, by a qualified technician
Motor stops (power cut out)	<ul style="list-style-type: none"> • Too much pressure exerted while cutting • Incorrect specification for saw blade • Saw has a defective electric system 	<ul style="list-style-type: none"> • Exert less pressure when cutting • Use a saw blade which corresponds to the material being cut • Have the electric system of the saw checked by a qualified technician

Trouble Shooting (continued)		
Problem	Possible Cause	Solution
Poor machine performance little power	<ul style="list-style-type: none"> • Power cord/extension cable too long or cable still wound up inside cable drum • Power network is insufficient • Drive motor no longer runs at rated speed RPM 	<ul style="list-style-type: none"> • Use a Power cord extension cable of the rated length, use a cable drum with cable fully extended. • Observe the electrical ratings of the machine and connect it only to a power network which complies with these ratings • Have the motor checked by a qualified electrician and have it replaced if necessary
Saw blade is blunt	<ul style="list-style-type: none"> • Power cord/extension cable too long or cable still wound up inside cable drum • Power network is insufficient • Drive motor no longer runs at rated speed RPM 	<ul style="list-style-type: none"> • Use a Power cord extension cable of the rated length, use a cable drum with cable fully extended. • Observe the electrical ratings of the machine and connect it only to a power network which complies with these ratings • Have the motor checked by a qualified electrician and have it replaced if necessary
Appearance of cut is not optimal	<ul style="list-style-type: none"> • Poor tension in the blade material • Too much load placed on the saw blade • Diamond segments are blunt 	<ul style="list-style-type: none"> • Return saw blade to manufacturer • Use a suitable saw blade • Sharpen the saw blade
The center hole in the saw blade has become wider due to wear	<ul style="list-style-type: none"> • The saw blade has slipped on the motor shaft when running 	<ul style="list-style-type: none"> • The arbor of the saw blade must be fitted w/ appropriated adaptor ring • Check the receiving flange and have it replaced if necessary
Saw blade shows blooming colors	<ul style="list-style-type: none"> • Saw blade overheating due to a lack of cooling water • Lateral friction when cutting 	<ul style="list-style-type: none"> • Ensure optimum flow of water • The material feed is too high; proceed more slowly
Grinding marks on the saw blade	<ul style="list-style-type: none"> • Material is not being fed parallel to blade • Poor tension in the blade material • Too much load on the saw blade 	<ul style="list-style-type: none"> • Ensure that the direction of feed is absolutely parallel to the saw blade • Adjust roller table • Have the saw blade tensioned • The material feed is too high, proceed more slowly

Belt Replacement

1. Turn off the saw before proceeding any further.
2. Loosen and remove the belt guard screws, then remove the belt guard.
3. Leave the blade tight in position and use your hand to hold the blade shaft tightly. Now loosen the pulley lock screw on the blade shaft pulley.
4. Carefully loosen the pulley and belt outward slightly, so there is a little slack in the belt.
5. Remove the old belt and replace with the new belt.
6. To reassemble, follow steps in reverse order.

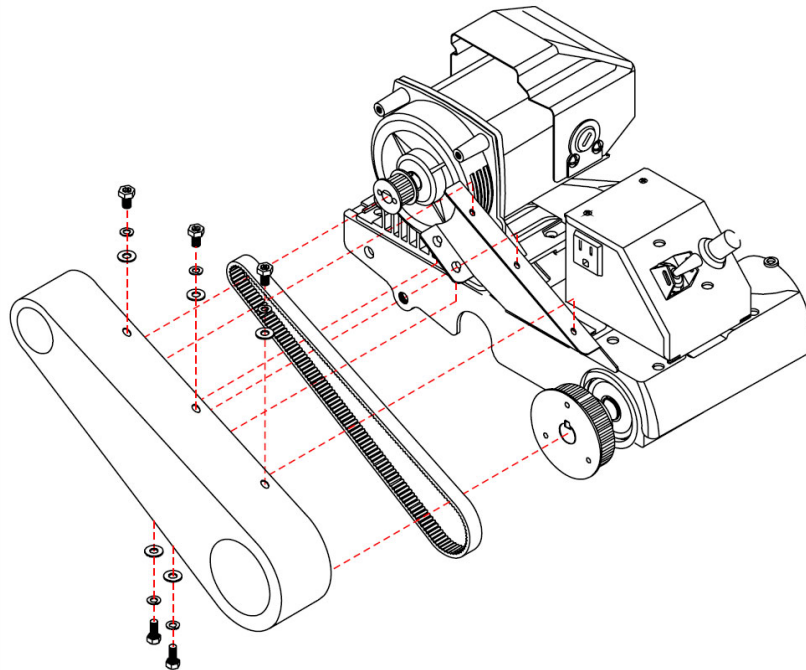

Belt Guard Removal

Belt Tensioning

Over time the CTC705 belts will need to be re-tensioned. This is a normal maintenance item that must be performed with any machine utilizing micro-v belts. With usage the micro-v belts will stretch and wear which increases the length of the belt and decreases the belt tension.

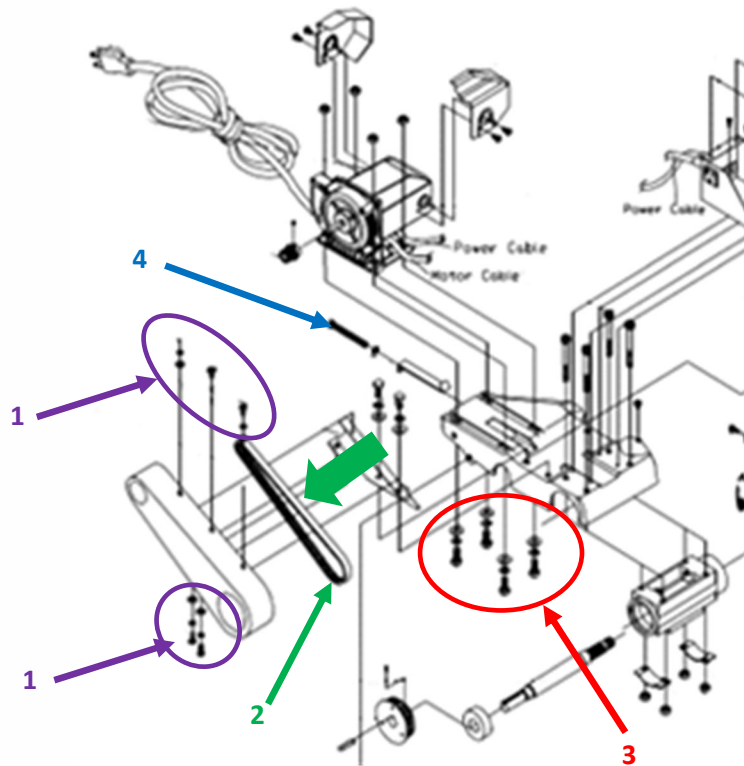

Belt Tensioning

1. Unplug the saw from the power supply.
2. Verify that the Power Switch is in the OFF position
3. Remove the belt guard (see #1 in the Figure: **Belt Tensioning**) by removing all six (6) Belt Guard Retaining screws.
4. Press down on the top middle of the belt. (see #2 in the Figure: **Belt Tensioning**).
 - a. 3/8" downward movement indicates the ideal belt tension.
 - i. If the belt can be moved more than 3/8" downward the belt will need to be tensioned
 - ii. If the belt moves less than 3/8" downward the belt is too tight and needs to be loosen
 - b. The Z shaped bracket that tensions the motor needs to be tightened. Do this by tightening the Bolt to Tension the motor (turn clockwise).
5. Inspect the belt for damaged, cracks, dry rot, or frayed edges. If the belt is damaged in anyway replace it immediately for best performance.
6. Loosen the four (4) motor retaining screws under the cutting head. Loosen only enough to move the motor (see #3 in the Figure: **Belt Tensioning**). NOTE: Do not remove these screws.
7. Changing the belt Tension
 - a. If the belt needs to be tensioned turn the screw for the Belt Tensioner (see #4 in the Figure: **Belt Tensioning**) clockwise until 3/8" of deflection is reached in the belt when pushed down on the middle. This will move the motor away from the blade shaft.
 - b. If the belt needs to be loose turn the screw for the Belt Tensioner (see #4 in the Figure: **Belt Tensioning**) counter-clockwise until 3/8" of deflection is reached in the belt when pushed down on the middle. This will move the motor towards the blade shaft.
8. Tighten the four (4) Motor four (4) motor retaining screws under the cutting head (see #3 in the Figure: **Belt Tensioning**).

- Reinstall the Belt Guard and tighten all six (6) of the Belt Guard Retaining screws with lock washers and flat washers (see #1 in the Figure: **Belt Tensioning**).

Belt Replacement

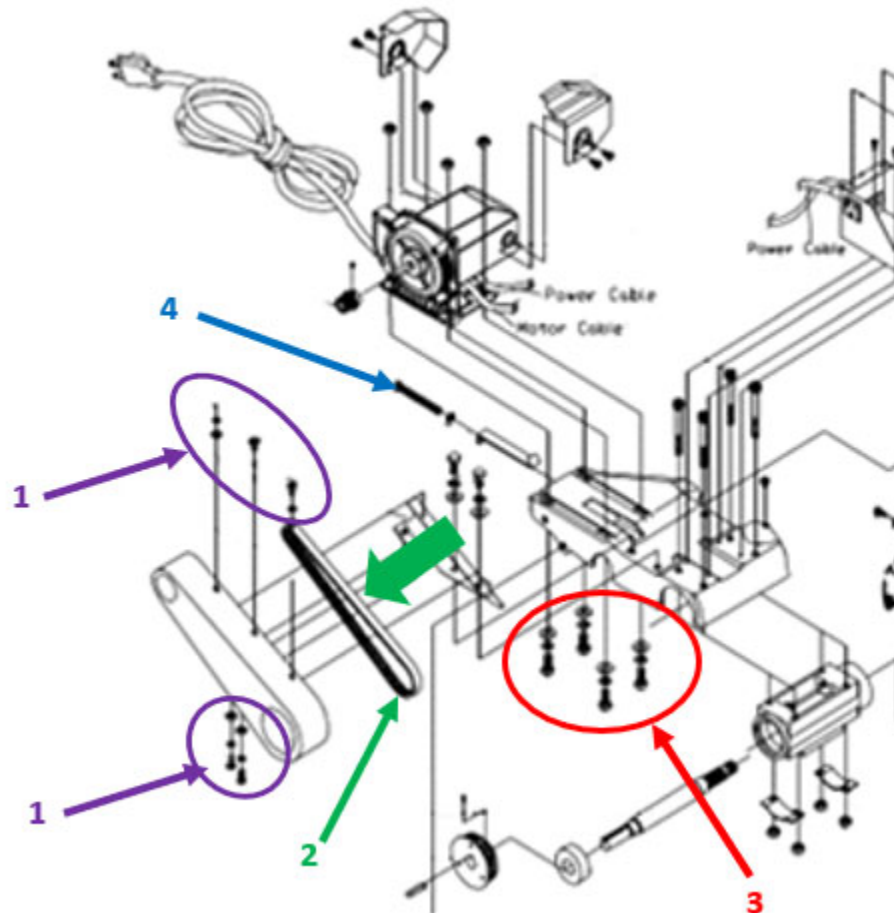

Belt Replacement

- Unplug the saw from the power supply.
- Verify that the Power Switch is in the OFF position
- Remove the belt guard (see #1 in the Figure: **Belt Replacement**) by removing all six (6) Belt Guard Retaining screws.
- Loosen the four (4) motor retaining screws under the cutting head. Loosen only enough to move the motor (see #3 in the Figure: **Belt Replacement**). NOTE: Do not remove these screws.
- Move the motor towards the Blade Shaft by turning the Motor Tensioning Screw (see #4 in the Figure: **Belt Replacement**), clockwise until the motor does not move any more. NOTE: It may be necessary to push the motor towards the blade shaft if it does not move freely.
- Remove the old belt from the pulleys (see #2 in the Figure: **Belt Tensioning**).
- Clean out the inside of the belt guard and pulleys of any worn rubber from the old belt or any other debris.

8. Place the new belt on the pulleys (see #2 in the Figure: **Belt Tensioning**) taking care to ensure that the micro-v of the belt is in the micro-v of both the motor and blade shaft pulleys.
9. Tension the belt by moving the motor away from the blade by turning the Belt Tensioner Screw Clockwise (see #4 in the Figure: **Belt Tensioning**) until 3/8" of deflection is reached in the belt when pushed down on the middle.

NOTE: If less than 3/8" deflection is in the belt it the belt has too much tension and the motor will need to be moved towards the blade shaft by turning the screw for the Belt Tensioner (see #4 in the Figure: **Belt Tensioning**) counterclockwise until 3/8" of deflection is reached.

10. Verify the Pulley Alignment with a straight edge.

- a. Line up the straight edge along the outside face of the motor and blade shaft pulley as shown in Figure 1.
- b. Misalignment will show up as a gap between the pulley face and the straight edge.
- c. Make sure that the width of the outside land is equal on the motor and blade shaft pulleys.
- d. If one of the pulleys is not aligned to the other, it is due to:
 - a). The motor pulley and the blade shaft are not parallel. [See figure 1]
 - i. Pulley will need to be moved to align.
 - b). The pulleys are not located properly on the shafts. [See figure 2]
 - i. Motor is not straight in the Motor Adjustment Slots

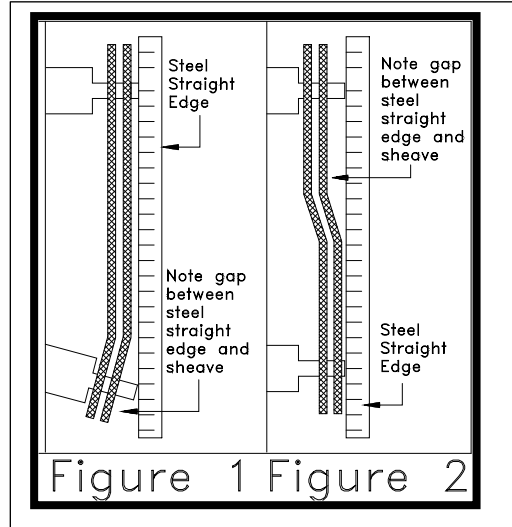

11. Tighten the four (4) Motor four (4) motor retaining screws under the cutting head (see #3 in the Figure: **Belt Tensioning**).
12. Reinstall the Belt Guard and tighten all six (6) of the Belt Guard Retaining screws with lock washers and flat washers (see #1 in the Figure: **Belt Tensioning**).
13. Verify that all hardware is properly tightened.
14. Verify that everyone is wearing the proper PPE.
15. Connect the machine to 115v/60Hz/1 Phase power.
16. Turn on the machine.
 - a. If any strange noises are present turn of the machine and check all work preformed up to this step.
17. Allow the machine to run for 15 minutes to properly seat the belts.
18. Once a month check the belt tension or check if the blade stalls in the cut or any squealing or other strange noise are present in the belt guard area..

Main Causes of Belt Failures:

Premature Belt failure can be attributed to the following issues: Tension (too much or too little), Pulley Misalignment, Damaged Pulleys, Improper Handling or Storage, Incorrect Blade Specification for Material Being Cut, and Cutting Too Deep.

Symptom	Possible Cause	Corrective Action
Belt Breakage	Too Much Tension	Re-tension Belts
	Excessive Shock Load	Reduce Load/ Check Blade Specification
	Pulley Out Of Round	Replace Pulley
Burning of Belt	Too Little Belt Tension	Increase Belt Tension
	Excessive Load (Cutting Full Depth)	For Best Performance Only Cut only 1-1/2" to 2" Per Pass
	Containments On Belts	Replace Belts and Find Source of Containments
	Incorrect Blade Specification	Replace Blade with One Designed For Material Being Cut
Symptom	Possible Cause	Corrective Action
Belt Tearing/Ripping	Pulley Misalignment	Align Pulleys
Belt Rolling Off Pulley	Pulley Misalignment	Align Pulleys
Belt Cracking	Extremely Low Temperature at Startup	Warm Machine Before Use
	Exposure To Chemicals or Lubricates	Locate Source of Containments and Replace Belts.

Brush Replacement

Brushes will wear with usage and is part of the machine’s basic maintenance. Replace the brushes when the motor begins to lose power. Brushes typically need to be replaced During the life of the saw. Replace the brushes when the motor begins to lose power, or if the motor has gotten wet, or the motor is slow to get up to speed, or any strange noises come from the motor, or if the motor is experiencing internal sparking. Replace the brushes when the length reaches 6.6mm (1/4”). It is normal for the brushes to wear with usage.

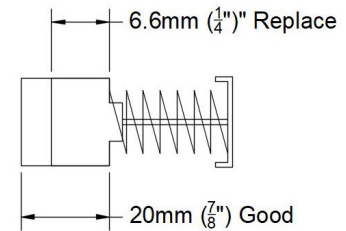

UPC	Description	NOTES
70184683358	CARBON BRUSHES CTC705 (2)	Set of two (2) Brushes Dimensions :13mm (H) x 6.25mm (T) x 20mm (L)
70184683359	BRUSH CAP (1) 705	Sold as EACH

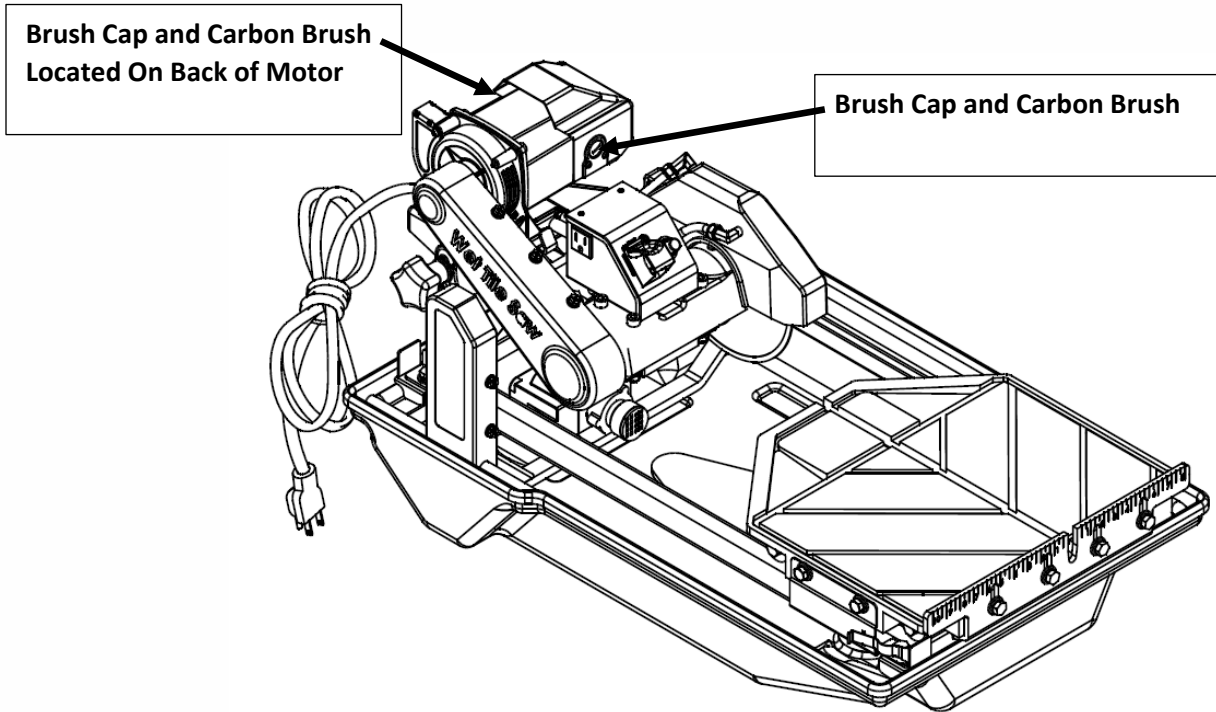

CTC705 Brush Locations

- c. Disconnect the power source from the CTC705
- d. There are two (2) brushes in the CTC705 motor, one (1) on each side. Always replace both brushes.
- e. Use a coin or wide blade screwdriver to remove the Carbon Brush Cap. Use care not to damage the Carbon Brush Cap.
 - i. Inspect the Carbon Brush Cap for damage. If the Cap has any signs of damage replace with 70184683359 BRUSH CAP (1) 705 NOTE: Brush Caps are sold individually.
4. Remove the Carbon Brush from the Brush Holder.
5. Remove the second brush following steps 3 and 4
6. Use low pressure compressed air to blow out the motor and brush holders. Motor while blowing out the motor. This will help clean any debris from inside of the motor.
7. Place the new Carbon Brush into one of the holders.
8. Replace the Brush Cap. Do not over tighten.
9. Repeat steps 7 and 8 for the remaining Carbon Brush
10. Connect the CTC705 to a 115v/60 Hz/1 Phase power source and test run.
 - a. If the machine does not start this is a sign that the Carbon Brush was not installed properly or was damaged during installation, repeat steps 1 to 10 again.
 - b. No power
 - c. Power switch in the OFF position
 - d. After checking 10a to 10c and the unit still does not run see a Norton Clipper Service center or your selling distributor for service.

Bearing Housing installation

1. Remove the 4 screws on the belt guard (Attach to Belt Guard Bracket).
2. Remove the belt guard from Bracket.
3. Loosen the tighten screw from the end of blade's Pulley Shaft, remove the Belt from Pulley.
4. Remove the blade nut and the blade (if there is one present).
5. Remove the 4 screws on the cutting head to remove the bearing housing (including the inner flange).

To install the new bearing housing:

1. Be sure that you have completed the instructions above to remove the old bearing housing.
2. Open the box and carefully place the flat portion of the new bearing housing face-down on a towel situated on a flat surface.
3. Secure the cutting head in a completely horizontal position.
4. Slide the new Bearing Housing with the flat portion facing upwards onto the 4 screws located below the Cutting Head. Do this carefully to avoid damage to the inner flange. Lock the bearing housing into place by using brackets and nuts.
5. Place the Belt on the pulleys, and make sure the Pulley lock screw is tight correctly direct to the key pin. Belt tightness has been pre-set. No adjustment necessary.

Warning: Do not adjust the Inner Flange that is attached the bearing housing from the original package.

6. Replace the belt guard and lock into place using the 6 screws.

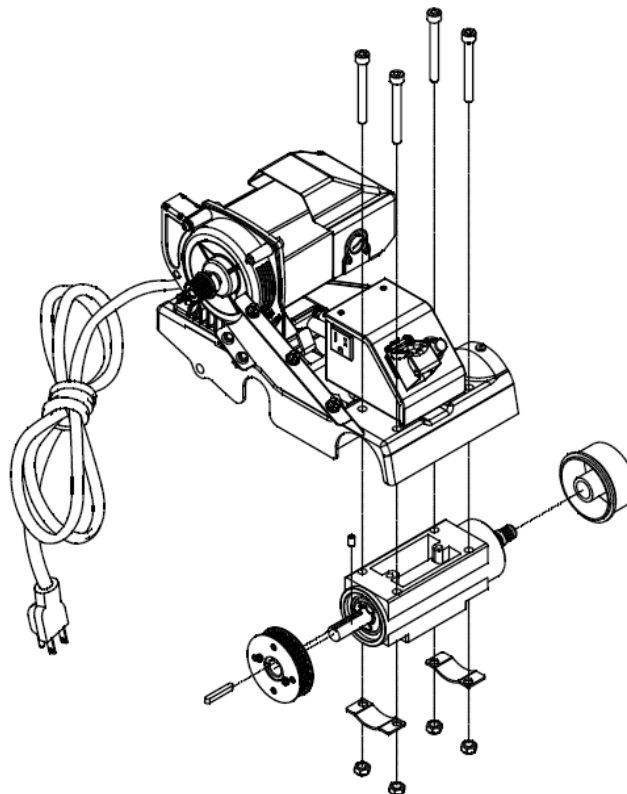

Water Pump Maintenance

When the machine has not been used for a long period of time, hard packed dirt may begin to build up inside the pump and block the pump wheel. If the machine is activated with the immersion pump blocked, the electric motor of the pump will be damaged within a few minutes! Please follow the steps listed below to clean the pump before and after operating the saw. Keeping the water pump clean will result in a long water pump life. Damage to water pumps due to not cleaning, or damage from slurry or debris are not covered under warranty.

1. At the end of each day remove the water pump from the CTC705 water pan.
2. Place the water pump in a container of clean water
3. Unscrew the pump filter.
4. Clean the immersion pump.
5. Loosen the fixing screws of the pump lid.
6. Take the lid off the pump (be careful not to damage the gasket located inside with a sharp object!)
7. Clean the pump lid.
8. Remove all dirt and incrustations from the pump wheel.
9. Check whether the pump wheel can be easily turned.
10. Then reassemble the immersion pump correctly and check whether it works properly by placing the water pump in a container of clean water and running the machine until clean water is moving thru all the water tubes.
11. Turn the machine off and disconnect the power supply.
12. Clean all debris out of the water pan.
13. NEVER place the water pump or leave the water pump in any slurry, mud, a dirty water pan, or in any debris.

Ordering Information

1. Provide the model number and serial number of the machine from the machine name plate.
2. Provide the UPC number, part number, and description of part.
3. Whenever alternate parts are shown due to product improvement, inspect the part you have and provide additional description as necessary.
4. Specify mode of shipping desired, for example, parcel post, truck, air freight, UPS., best way, etc.

Contact Customer Service:
Saint-Gobain Abrasives
2770 West Washington
Stephenville, TX 76401

Phone: 800-554-8003
Fax: 254-918-2312

Web: www.nortonabrasives.com

NOTE: All Parts Are Sold as Individual (each) Unless Noted Otherwise

Use Only Clipper Diamond Blades. Contact your local Norton Clipper Distributor or our Customer Service at 800-554-8003 for the best blade for the application.

All parts are designated as either Service Parts (S) or Wear Parts (W) in the Type column in the parts listing. Wear parts are worn out through normal use of the machine. The wear period depends on the intensity of use of the machine, handling, and maintenance of the machine. Wear parts must be serviced and eventually changed following the indications of the manufacturer. Any wear due to normal use of the machine will not be considered as a case of warranty for items designated as Wear Parts (W). For best performance and life Genuine Norton Clipper replacement parts should always be used. Changes to part specifications, are subject to change without notice.

CTC705 Exploded View

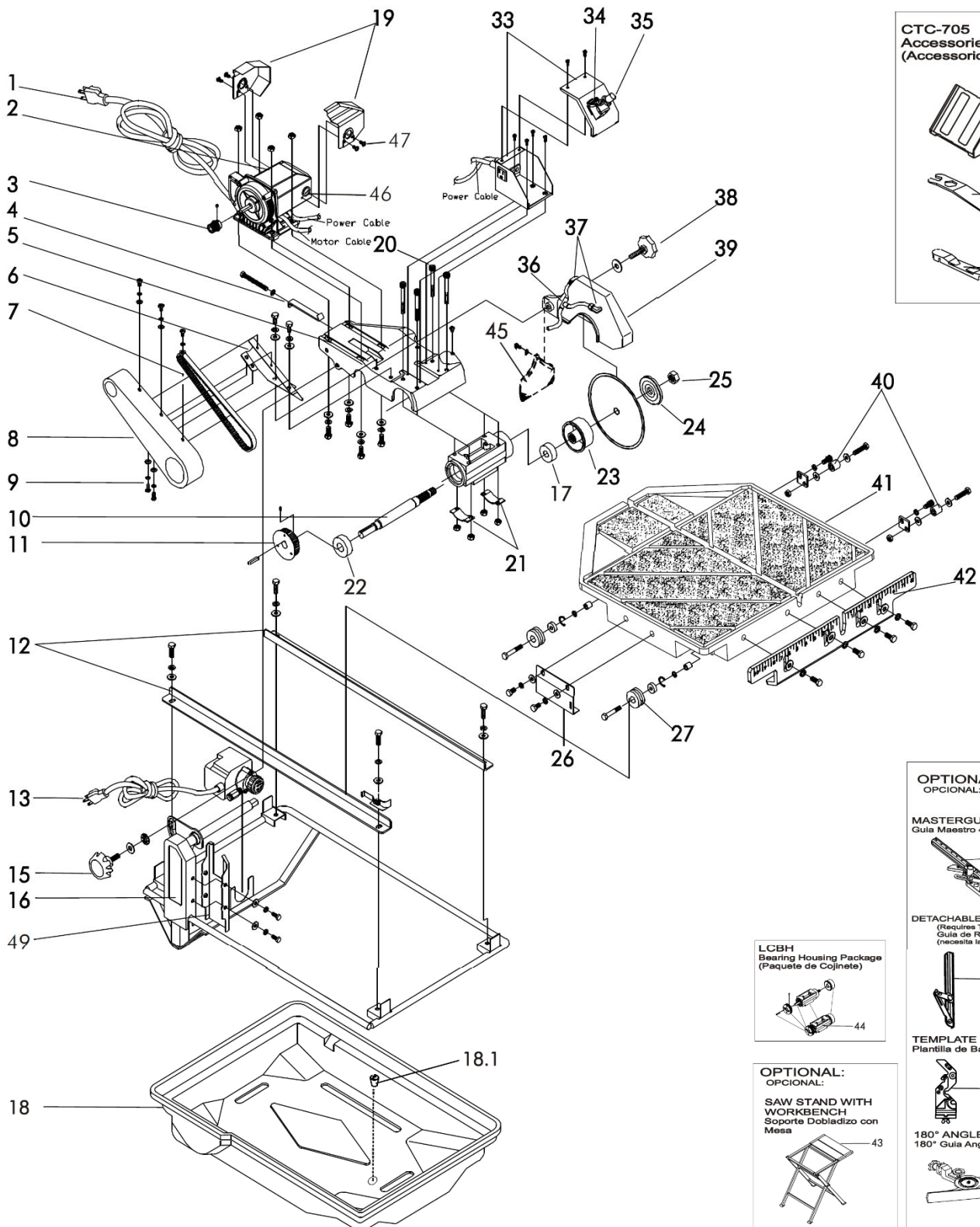

CTC705 Service Parts List

#	UPC	Part #	Description	QTY	Type
1	70184600874	233001	POWER CORD 7'	1	S
2	70184683352	234002	1 HP BRUSH MOTOR	1	S
3	70184682231	234003	MOTOR SHAFT PULLEY	1	S
4	70184600084	234004	MOTOR ADJUSTMENT CLIP	1	S
5	70184682551	234005	MOUNTING PLATE	1	S
6	70184600085	234006	BELT GUARD BRACKET	1	S
7	70184682230	234007	TIMING T SHAPE NYLON BELT	1	W
8	70184600086	234008	BELT GUARD	1	S
9	70184600087	234009-1	BELT GUARD SCREWS	1	W
10	70184680871	233013	BLADE SHAFT	1	S
11	70184682229	234011	BLADE SHAFT PULLEY	1	S
12	70184600083	234012	SLIDING RAILS (SET OF 2)	1	S
13	70184629524	234013	WATER PUMP	1	S
14	70184680907	233065	MASTERGUIDE DETACHABLE RULER GUIDE	1	S
15	70184600089	234015	MOUNTING PLATE ADJUSTMENT KNOB	1	S
16	70184603344	234016	REAR POST (INCLUDED IN METAL FRAME & MOTOR SUPPORT SHAFT)	1	S
17	70184627099	233012-1	INNER FLANGE BEARING	1	S
18	70184683228	234018	POLYPROPYLENE WATER TRAY	1	S
18	70184622675	233082	DRAIN PLUG	1	S
19	70184600090	234019	MOTOR PROTECTION COVER SHIELD	1	S
20	70184640970	232200	SCR M8 x 70 1.25 DIN912 SOCKET HEAD (Sold as EACH)	4	S
21	70184680912	233049	BEARING HOUSING SECURE BRACKETS (SET OF 2)	1	S
22	70184627098	233012	PULLEY BEARING	1	S
23	70184632541	234023	INNER FLANGE	1	S
24	70184631359	234024	OUTER FLANGE	1	S
25	70184650351	8142007	BLADE LOCK NUT 5/8-11 HEX	1	S
26	70184600092	234026	CUTTING TABLE POSITION BRACKET	1	S
27	70184683537	234027	U-SHAPE BALL BEARING ROLLERS (SET OF 2)	1	S
28	70184682406	234028	MITER BLOCK (METAL)	1	S
29	70184680905	233041	UNIVERSAL WRENCH	1	S
30	70184682710	234030	45° / 90° RIP GUIDE	1	S
31	70184680907	234043	180° ADJUSTABLE ANGLE GUARD	1	S
32	70184680907	233053	MASTERGUIDE MULTIANGLE GUIDE	1	S
33	70184680860	234035	POWER SWITCH HOUSING (W SWITCH)	1	S
34	70184680858	233003	POWER TOGGLE SWITCH 15A w/RUBBER BOOT	1	S
35	70184680859	234036	CIRCUIT BREAKER	1	S
36	70184680877	233019	WATER FLOW "T" ADAPTER	1	S
37	70184680909	233045	WATER FLOW "L" ADAPTER	1	S
38	70184680876	233018	BLADE GUARD ADJUSTMENT KNOB	1	S
39	70184600096	234040-1	BLADE GUARD	1	S
40	70184680883	234041	TEFLON ANGLE BAR ROLLERS (SET OF 2)	1	S
41	70184682713	234042	CUTTING TABLE (INCLUDES WHEELS & RULER GUIDE)	1	S
42	70184682714	234043	RULER GUIDE	1	S
43	70184643045	705STAND	SAW STAND WITH WORKBENCH	1	S
44	N/A	234044	COMPLETE LCBH (LIQUID COOLING BEARING HOUSING)	1	S
45	70184680902	234045	RUBBER SPLASH GUARD	1	S
46	70184683358	234046	CARBON BRUSHES (SET OF 2)	1	S
47	70184683359	234047	BRUSH CAP	1	S
48	70184680907	233066	MASTERGUIDE TEMPLATE BASE	1	S
49	70184624910	233084	REAR POST COVER	1	S

This page is left intentionally blank

WARNING

Some dust created by power sanding, sawing, grinding, drilling, and other construction activities contains chemicals known to cause cancer, birth defects or other reproductive harm. Some examples of these chemicals are:

- Lead from lead-based paints,
- Crystalline silica from bricks and cement and other masonry products, and
- Arsenic and chromium from chemically-treated lumber.

Your risk from these exposures varies, depending on how often you do this type of work. To reduce your exposure to these chemicals: work in a well ventilated area, and work with approved safety equipment, such as those dust masks that are specially designed to filter out microscopic particles.



REDEFINING
JOBSITE MUSCLE™

www.facebook.com/NortonAbrasivesNA | www.youtube.com/NortonAbrasives | www.nortonabrasives.com

USA CUSTOMER SERVICE:

Toll Free Phone: 1 (800) 554-8003
Toll Free Fax: 1 (800) 443-1092

CANADA CUSTOMER SERVICE:

Toll Free Phone: 1 (800) 263-6565
Toll Free Fax: 1 (800) 561-9490

© Saint-Gobain.

Norton, Norton Clipper, "Redefining Jobsite Muscle" and "Transforming surfaces...and beyond" are trademarks of Saint-Gobain. All other trademarks are the property of their respective owners.

