

RV140 SERIES ENGINE

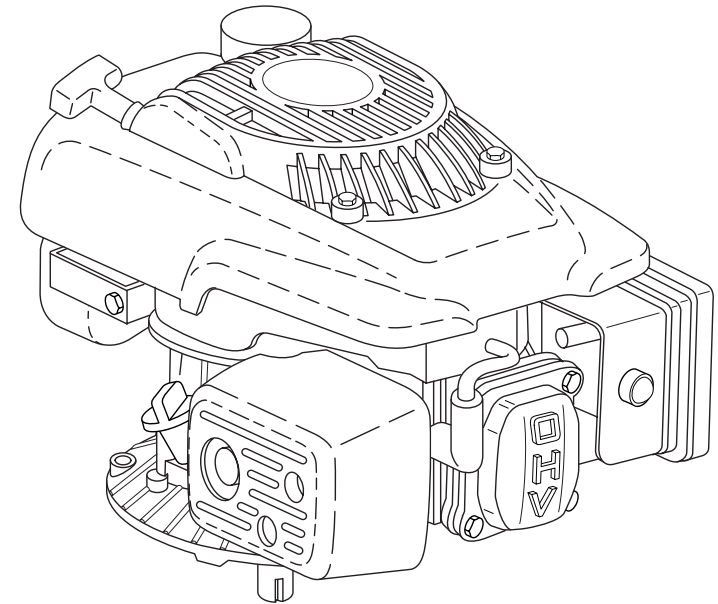
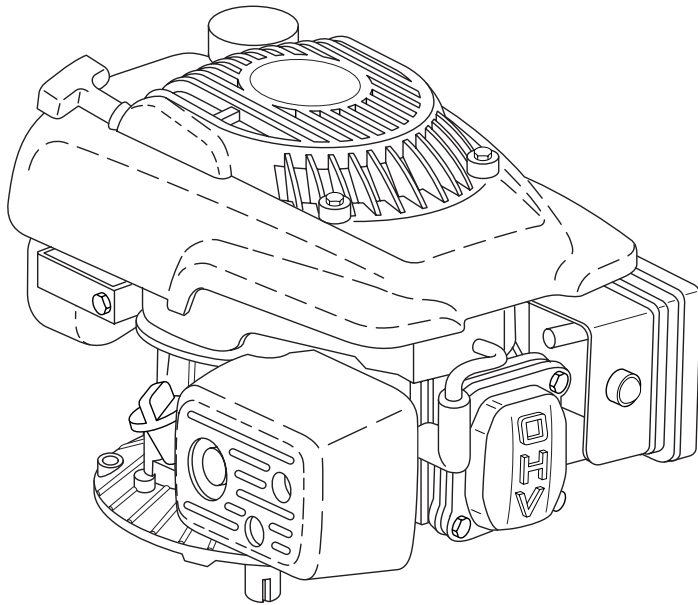

Owner's Manual (American)

Vertical Shaft, 4-Stroke, OHV,
140cc Gasoline-Powered Engine

CAUTION:

Read and follow all Safety Rules and Instructions
before attempting to operate this engine.

SAFETY RULES

Your safety and the safety of others is important. We have provided important safety information in this manual and on the engine itself. A safety message alerts you to potential hazards and risks which could hurt you or others. Each message is preceded by a safety alert symbol  and one of the three following words:

 DANGER: indicates a hazard which, if not avoided, **will result in death or serious injury**, could damage your engine and/or void your warranty.

 WARNING: indicates a hazard which, if not avoided, **could result in death or serious injury**.

 CAUTION: indicates a hazard which, if not avoided, **could result in minor to moderate injury**.

 WARNING: In order to prevent accidental starting when setting up, transporting, adjusting or making repairs, always disconnect spark plug wire and place wire where it cannot come in contact with spark plug.

 WARNING: Engine exhaust, some of its constituents, and certain vehicle components contain or emit chemicals known to the State of California to cause cancer and birth defects or other reproductive harm.

 CAUTION: Muffler and other engine parts become extremely hot during operation and remain hot after engine has stopped. To avoid severe burns on contact, stay away from these areas.



I. GENERAL OPERATION

- Read, understand, and follow all instructions on the engine and in this manual before starting. Be thoroughly familiar with the controls and the proper use of the machine before starting.
- Do not change the engine governor setting or overspeed the engine.
- Do not run the engine at a low load at a low speed for a long period of time.
- Use only specified grades of gasoline and oil.
- Keep area around fuel filler cap clean.
- Maintain the air filter and change the oil as indicated in the Maintenance section of this manual.
- Make repairs when needed. Do not operate engine with anything damaged or missing.

II. SAFE HANDLING OF GASOLINE

Use extreme care in handling gasoline. Gasoline is extremely flammable and the vapors are explosive.

- Extinguish all cigarettes, cigars, pipes and other sources of ignition.
- Use only an approved container.
- Never remove gas cap or add fuel with the engine running. Allow engine to cool before refueling.
- Never refuel the machine indoors.
- Never store the machine or fuel container where there is an open flame, spark or pilot light such as a water heater or on other appliances.

- Never fill containers inside a vehicle, on a truck or trailer bed with a plastic liner. Always place containers on the ground away from your vehicle before filling.
- Remove gas-powered equipment from the truck or trailer and refuel it on the ground. If this is not possible, then refuel such equipment with a portable container, rather than from a gasoline dispenser nozzle.
- Keep the nozzle in contact with the rim of the fuel tank or container opening at all times until fueling is complete. Do not use a nozzle lock-open device.
- If fuel is spilled on clothing, change clothing immediately.
- Never overfill fuel tank. Replace gas cap and tighten securely.

III. GENERAL SERVICE

- Never run engine inside a closed area.
- Never make adjustments or repairs with the engine running. Disconnect the spark plug wire and keep the wire away from the spark plug to prevent accidental starting.
- Periodically check nuts and bolts for proper tightness.
- Never tamper with safety devices. Check their proper operation regularly.
- Keep engine free of grass, leaves, or other debris build-up. Clean oil or fuel spillage. Allow machine to cool before storing.
- Maintain or replace safety and instruction labels, as necessary.

SERVICE NOTES

EMISSION RELATED PARTS INCLUDE THE FOLLOWING:

- 1) Fuel Metering System:
 - a) Gasoline carburetor assembly and its internal components.
 - b) Fuel filter (if so equipped)
 - c) Carburetor gaskets
 - d) Fuel pump (if so equipped)
- 2) Air Induction System including:
 - a) Intake pipe/manifold
 - b) Air cleaner
- 3) Ignition System including:
 - a) Spark plug
 - b) Ignition module/coil
- 4) Catalytic Muffler Assembly (if so equipped) including:
 - a) Muffler gasket
 - b) Exhaust manifold
- 5) Miscellaneous including:
 - a) Hoses, belts and connectors.

TABLE OF CONTENTS

Safety Rules	2	Maintenance	6-7
Product Specifications	4	Service and Adjustments	7
Pre-Operation	4	Troubleshooting	8-9
Operation	5	Torque Values	9
Maintenance Schedule	6	Repair Parts	10-11

KNOW YOUR ENGINE

READ THIS OWNER'S MANUAL AND ALL SAFETY RULES BEFORE OPERATING YOUR ENGINE. Compare the illustrations with your engine to familiarize yourself with the location of various controls and adjustments. Save this manual for future reference.

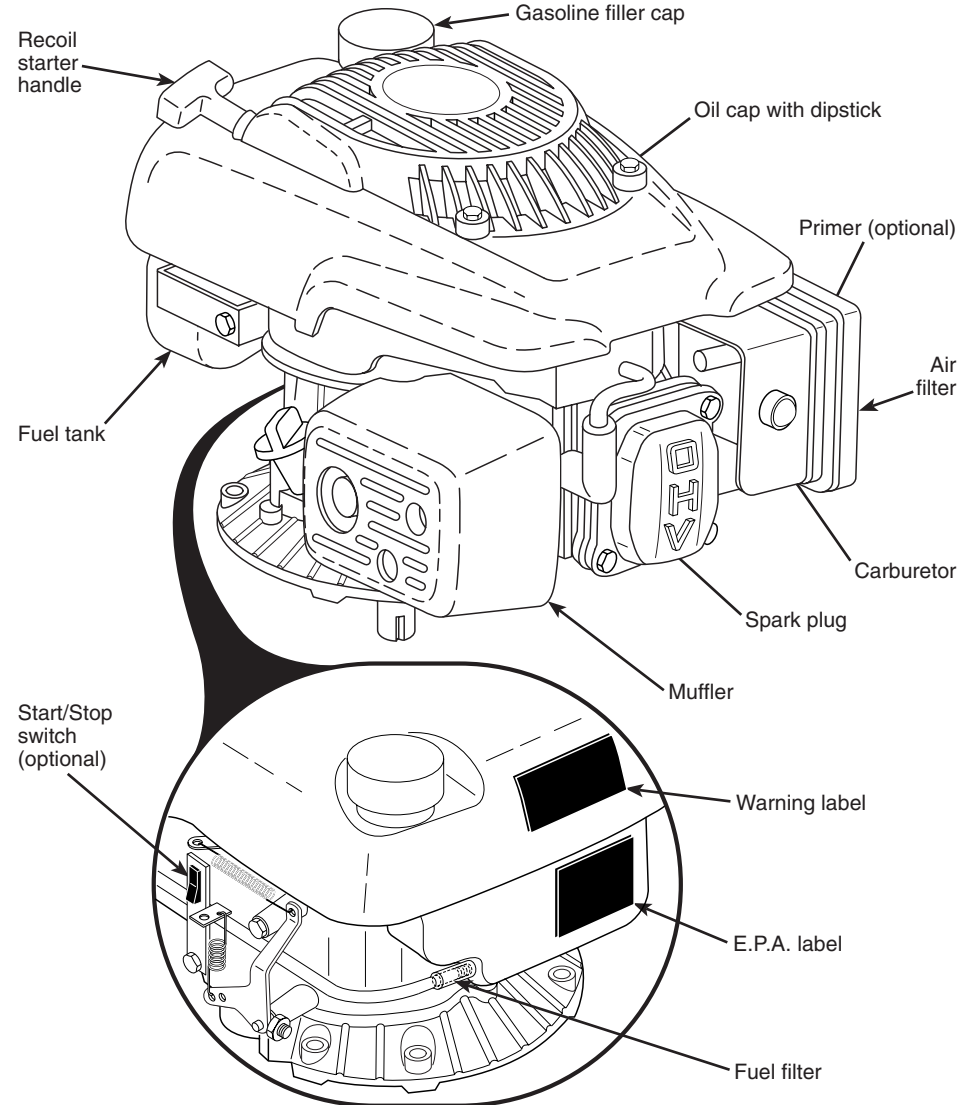

IMPORTANT: This engine is shipped WITHOUT OIL OR GASOLINE.

PRODUCT SPECIFICATIONS

Serial Number:	
Date of Purchase:	
•The model and serial numbers will be found on the rear of the engine housing. Record both serial number and date of purchase in the space provided above.	
Gasoline Capacity / Type:	1.14 Quarts / 1 Litre (Unleaded Regular)
Oil Capacity:	15.5 Ounces / 0,45 Litres
Oil Type (API SG–SL):	SAE 10W-30 (or SAE 30 above 10°C/40°F, or SAE 5W-30 below 0°C/32°F)
Spark Plug: (Gap: .030" / 0,76 mm)	N.G.K. BP6ES or BPR6ES Champion N11YC or RN11YC N.H.S.P. F6TC or F6RTC Torch F6TC or F6RTC
Dry Weight: 24.91 lbs. / 11.3 kg	Displacement: 140cc / 139,36ml
Bore x Stroke: 65 x 42mm	Carburetor Idle Speed: 1900 RPM (±100)
Valve Clearance (cold engine):	Intake: 0.15mm (±0.02); Exhaust: 0.20mm (±0.02)

PRE-OPERATION

BEFORE STARTING ENGINE

ADD OIL

Your lawnmower is shipped without oil in the engine. For type /grade oil to use, see the Maintenance section of this manual.

⚠ CAUTION: DO NOT overfill engine with oil, or it will smoke on startup.

1. Be sure lawnmower is level.
2. Remove oil fill cap from oil fill spout.
3. Engine holds 15.5 oz. of oil. Pour oil slowly. Do not overfill. Wait one minute to allow oil to settle. Use gauge on oil fill cap/dipstick for checking level. Insert dipstick into the tube and rest the oil fill cap on the tube. DO NOT thread the cap into the tube when taking reading.
4. Insert and tighten oil fill cap/dipstick.

IMPORTANT:

- Check oil level before each use. Add oil if needed. Fill to full line on dipstick.
- Change the oil after every 25 hours of operation or each season. You may need to change the oil more often under dusty, dirty conditions. See "TO CHANGE ENGINE OIL" in the Maintenance section of this manual.

ADD GASOLINE

- Fill fuel tank to bottom of tank filler neck. Do not overfill. Use fresh, clean, regular unleaded gasoline with a minimum of 87 octane. Do not mix oil with gasoline. Purchase fuel in quantities that can be used within 30 days to assure freshness.

⚠ CAUTION: Wipe off any spilled oil or fuel. Do not store, spill or use gasoline near an open flame.

⚠ CAUTION: Alcohol blended fuels (called gasohol or using ethanol or methanol) can attract moisture which leads to separation and formation of acids during storage. Acidic gas can damage the fuel system of an engine while in storage. To avoid engine problems, the fuel system should be emptied before storage of 30 days or longer. Empty the gas tank, start the engine and let it run until the fuel lines and carburetor are empty. Use fresh fuel next season. See Storage Instructions for additional information. Never use engine or carburetor cleaner products in the fuel tank or permanent damage may occur.

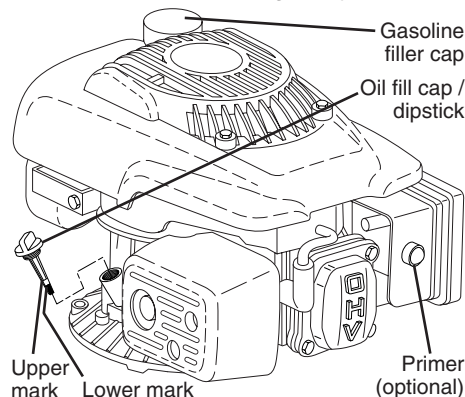

II. EMISSION CONTROL SYSTEM WARRANTY

Emission Control System Warranty (ECS Warranty) for 1997 and later model engines:

(a) Applicability: This warranty shall apply to 1997 and later model year engines. The ECS Warranty Period shall begin on the date the new engine or equipment is purchased by/delivered to its original, end-use purchaser/owner and shall continue for 24 consecutive months thereafter.
 (b) General Emissions Warranty Coverage: HUSQVARNA OUTDOOR PRODUCTS INC. warrants to the original, end-use purchaser/owner of the new engine or equipment and to each subsequent purchaser/owner that each of its engines is...

(1) Designed, built and equipped so as to conform with all applicable regulations adopted by the EPA and CARB pursuant to their respective authority, and

(2) Free from defects in materials and workmanship which, at any time during the ECS Warranty Period, may cause a warranted emissions-related part to fail to be identical in all material respects to the part as described in the engine manufacturer's application for certification.

The ECS Warranty only pertains to emissions-related parts on your engine, as follows:

(1) Any warranted, emissions-related parts that are not scheduled for replacement as required maintenance in the Owner's Manual shall be warranted for the ECS Warranty Period. If any such part fails during the ECS Warranty Period, it shall be repaired or replaced by HUSQVARNA OUTDOOR PRODUCTS INC. according to Subsection (4) below. Any such part repaired or replaced under the ECS Warranty shall be warranted for the remainder of the ECS Warranty Period.

(2) Any warranted, emissions-related part that is scheduled only for regular inspection as specified in the Owner's Manual shall be warranted for the ECS Warranty Period. A statement in such written instructions to the effect of "repair or replace as necessary" shall not reduce the ECS Warranty Period. Any such part repaired or replaced under the ECS Warranty shall be warranted for the remainder of the ECS Warranty Period.

(3) Any warranted, emissions-related part that is scheduled for replacement as required maintenance in the Owner's Manual shall be warranted for the period of time prior to the first scheduled replacement point for that part. If the part fails prior to the first scheduled replacement, the part shall be repaired or replaced by HUSQVARNA OUTDOOR PRODUCTS INC. according to Subsection (4) below. Any such emissions-related part repaired or replaced under the ECS Warranty shall be warranted for the remainder of the ECS Warranty Period prior to the first scheduled replacement point for such emissions-related part.

(4) Repair or replacement of any warranted, emissions-related part under this ECS Warranty shall be performed at no charge to the owner at a HUSQVARNA OUTDOOR PRODUCTS INC. Authorized Warranty Service Facility.

(5) When the engine is inspected by a HUSQVARNA OUTDOOR PRODUCTS INC. Authorized Warranty Service Facility, the owner shall not be held responsible for diagnostic costs if the repair is deemed warrantable.

(6) HUSQVARNA OUTDOOR PRODUCTS INC. shall be liable for damages to other original engine components or approved modifications proximately caused by a failure under warranty of any emission-related part covered by the ECS Warranty.

(7) Throughout the ECS Warranty Period, HUSQVARNA OUTDOOR PRODUCTS INC. shall maintain a supply of warranted emission-related parts sufficient to meet the expected demand for such emission-related parts.

(8) Any HUSQVARNA OUTDOOR PRODUCTS INC. authorized and approved emission-related replacement part may be used in the performance of any ECS Warranty maintenance or repairs and will be provided without charge to the purchaser/owner. Such use shall not reduce HUSQVARNA OUTDOOR PRODUCTS INC.'s ECS Warranty obligations.

(9) Unapproved, add-on, modified, counterfeit and/or "grey market" parts may not be used to modify or repair a HUSQVARNA OUTDOOR PRODUCTS INC. engine. Such use voids this ECS Warranty and shall be sufficient grounds for disallowing an ECS Warranty claim. HUSQVARNA OUTDOOR PRODUCTS INC. shall not be held liable hereunder for failures of any warranted parts of a HUSQVARNA OUTDOOR PRODUCTS INC. engine caused by the use of such an unapproved, add-on, modified, counterfeit and/or "grey market" part.

I. CALIFORNIA AND FEDERAL EMISSION CONTROL WARRANTY STATEMENT

YOUR WARRANTY RIGHTS AND OBLIGATIONS

The California Air Resources Board (CARB) and the United States Environmental Protection Agency (EPA), together with HUSQVARNA OUTDOOR PRODUCTS INC. are pleased to explain the Emission Control System Warranty on your new small off-road engine. New small off-road engines must be designed, built and equipped to meet stringent anti-smog standards for the state of California and the federal government. HUSQVARNA OUTDOOR PRODUCTS, INC. will warrant the emission control system on your engine for the periods of time listed below provided there has been no abuse, neglect, unapproved modification or improper maintenance of your engine.

Your emission control system may include parts such as the carburetor, ignition, intake and exhaust systems. HUSQVARNA OUTDOOR PRODUCTS, INC. will repair your engine at no cost to you for diagnosis, replacement parts and labor, should a warrantable condition occur.

MANUFACTURER'S EMISSION CONTROL SYSTEM WARRANTY COVERAGE:

Emission control systems on 1997 and later model year engines are warranted for two years as hereinafter noted. If, during such warranty period, any emission-related component or system on your engine is found to be defective in materials or workmanship, repairs or replacement will be performed by a HUSQVARNA OUTDOOR PRODUCTS, INC. Authorized Warranty Service Facility.

PURCHASER'S/OWNER'S WARRANTY RESPONSIBILITIES:

As the small off-road engine purchaser/owner, you are responsible for the completion of all required maintenance as listed in your factory supplied Owner's Manual. For warranty purposes, HUSQVARNA OUTDOOR PRODUCTS, INC. recommends that you retain all receipts covering maintenance on your engine. However, HUSQVARNA OUTDOOR PRODUCTS, INC. cannot deny warranty solely because of the lack of receipts or for your failure to ensure the completion of all scheduled maintenance.

As the small off-road engine purchaser/owner, you should, however, be aware that HUSQVARNA OUTDOOR PRODUCTS INC. may deny any and/or all warranty coverage or responsibility if your engine, or a part/component thereof, has failed due to abuse, neglect, improper maintenance or unapproved modifications, or the use of counterfeit and/or "grey market" parts not made, supplied or approved by HUSQVARNA OUTDOOR PRODUCTS, INC.

You are responsible for presenting your engine to a HUSQVARNA OUTDOOR PRODUCTS INC. Authorized Warranty Service Facility as soon as a problem occurs. The warranty repairs should be completed in a reasonable amount of time, not to exceed 30 days.

Warranty service can be arranged by contacting either your selling dealer or a HUSQVARNA OUTDOOR PRODUCTS INC. Authorized Warranty Service Facility. To locate the HUSQVARNA OUTDOOR PRODUCTS INC. Authorized Warranty Service Facility nearest you at 1(800)487-5951 or go to www.husqvarna.com and click on Support.

IMPORTANT NOTE: This warranty statement explains your rights and obligations under the Emission Control System Warranty (ECS Warranty), which is provided to you by HUSQVARNA OUTDOOR PRODUCTS INC. pursuant to California and federal law. See also the "Limited Warranties for HUSQVARNA OUTDOOR PRODUCTS, INC.," which is enclosed herewith on a separate sheet, also provided to you by HUSQVARNA OUTDOOR PRODUCTS, INC. The ECS Warranty applies only to the emission control system of your new engine. If there is any conflict in terms between the ECS Warranty and the HUSQVARNA OUTDOOR PRODUCTS, INC. Warranty, the ECS Warranty shall apply except in circumstances where the HUSQVARNA OUTDOOR PRODUCTS, INC. Warranty may provide a longer warranty period. Both the ECS Warranty and the HUSQVARNA OUTDOOR PRODUCTS, INC. Warranty describe important rights and obligations with respect to your new engine.

Warranty service can be performed only by a HUSQVARNA OUTDOOR PRODUCTS, INC. Authorized Warranty Service Facility. When requesting warranty service, evidence must be presented showing the date of the sale to the original purchaser/owner. The purchaser/owner shall be responsible for any expenses or other charges incurred for service calls and/or transportation of the product to/from the inspection or repair facilities. The purchaser/owner shall also be responsible for any and/or all damages or losses incurred while the engine is being transported/shipped for inspection or warranty repairs.

IF YOU HAVE ANY QUESTIONS REGARDING YOUR WARRANTY RIGHTS AND RESPONSIBILITIES, YOU SHOULD CONTACT HUSQVARNA OUTDOOR PRODUCTS, INC. at 1(800) 487-5951.

OPERATION

TO STOP ENGINE (*all models*)

- To stop engine, release operator presence control bar and/or place engine START/STOP switch (if equipped) in the OFF position.

TO START ENGINE (*all models*)

NOTE: Due to protective coatings on the engine, a small amount of smoke may be present during the initial use of the product and should be considered normal.

- Place engine START/STOP switch (if equipped) in the ON position.

MODELS WITH PRIMER:

- To start a cold engine, push primer three (3) times before trying to start. Use a firm push. This step is not usually necessary when starting an engine which has already run for a few minutes.

NOTE: In cooler weather it may be necessary to repeat priming steps. In warmer weather over priming may cause flooding and engine will not start. If you do flood engine, wait a few minutes before attempting to start and do not repeat priming steps.

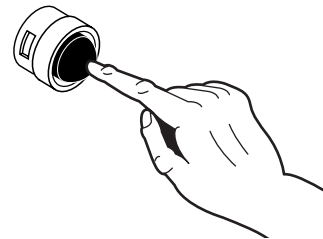

MODELS WITH CHOKE:

- To start a cold engine, move handle mounted choke control lever to CHOKE position.

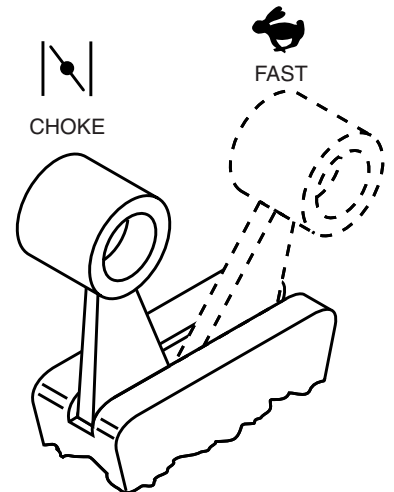

MODELS WITH THROTTLE:

- Move handle mounted throttle control lever in FAST position.

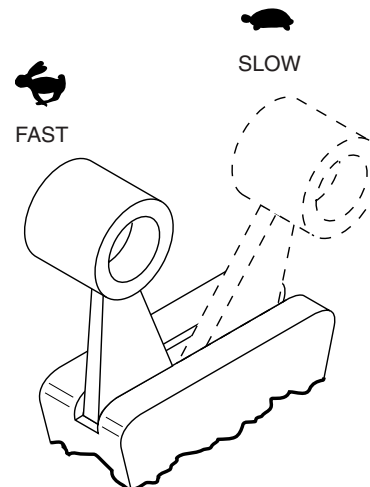

ALL MODELS (*continued*)

- Hold operator presence control bar down to the handle and pull starter handle quickly. Do not allow starter rope to snap back.

MODELS WITH CHOKE:

- Slowly move choke control lever to FAST position after engine starts.

MAINTENANCE

MAINTENANCE SCHEDULE	BEFORE EACH USE	FIRST 20 HOURS	EVERY 50 HOURS OR SEASON	EVERY 100 HOURS	BEFORE STORAGE	EVERY THREE YEARS
Check for Loose Fasteners	✓					
Check Engine Oil level	✓				✓	
Change Engine Oil		✓		✓ _{1,2}		
Clean Air Filter	✓					
Replace Air Filter Paper Cartridge			✓ ₂			
Inspect Muffler				✓		
Replace Fuel Filter				✓		
Replace Spark Plug				✓		
Clean Cylinder Head of Debris				✓		
Empty fuel system or add Stabilizer					✓	
Replace Fuel Tank						✓

- 1 - Change more often if operating under a heavy load or in high outdoor temperatures.
 2 - Service more often if operating in dirty or dusty conditions.

LUBRICATION

Use only high quality detergent oil rated with API service classification SJ-SL. Select the oil's SAE viscosity grade according to your expected operating temperature.

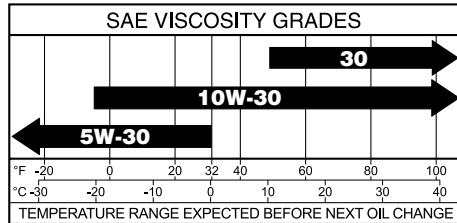

Change the oil after every 25 hours of operation or at least once a year if the lawn mower is not used for 25 hours in one year. Check the crankcase oil level before starting the engine and after each five (5) hours of continuous use. Tighten oil plug securely each time you check the oil level.

TO CHANGE ENGINE OIL

NOTE: Before tipping engine to drain oil, empty fuel tank by running engine until fuel tank is empty.

1. Disconnect spark plug wire from spark plug and place wire where it cannot come in contact with plug.
2. Remove oil fill cap/dipstick; lay aside on a clean surface.
3. Tip engine on its side as shown and drain oil into a suitable container. Rock engine back and forth to remove any oil trapped inside of engine.

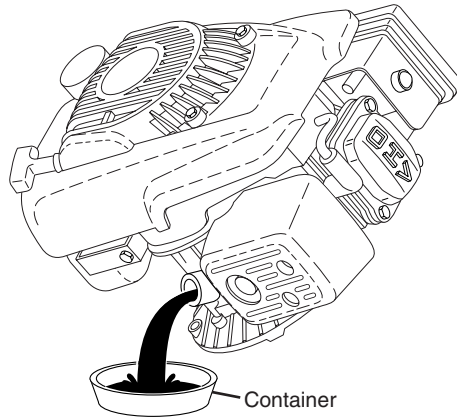

4. Wipe off any spilled oil from side of engine.
5. Fill engine with oil. Slowly pour oil down the oil fill spout into the engine.
6. Wait one minute to allow oil to settle. Use gauge on oil fill cap/dipstick for checking level. Insert dipstick into the tube and rest the oil fill cap on the tube. **DO NOT** thread the cap into the tube when taking reading.

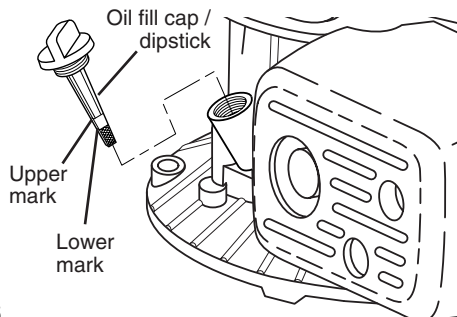

REPAIR PARTS

[Order RV140 engine parts on eBay](#)

KEY NO.	PART NO.	QTY.	DESCRIPTION
1	532 43 75-56	1	Cover, Cylinder Head
2	532 43 75-57	1	Gasket, Cylinder Head
3	532 43 75-58	1	Spark Plug
4	532 43 75-59	1	Oil Dipstick Assembly
5	532 43 75-62	1	Recoil Starter Assembly
6	532 43 75-63	1	Handle, Recoil Stater
7	532 43 75-64	1	Service Kit, Carburetor (Includes Insulator Plate, Insulator Plate Gasket and Caburetor Gasket)
8	532 43 75-65	1	Carburtor Assembly
9	532 43 75-66	1	Gasket, Air Cleaner
10	532 43 75-67	1	Breather Tube
11	532 43 75-68	2	Nut, Air Cleaner
12	532 43 75-69	1	Case, Air Cleaner
13	532 43 75-70	1	Air Cleaner Assembly
14	532 43 75-71	1	Cover, Air Cleaner Case
15	532 43 93-77	1	Air Filter
16	532 43 75-72	1	Cover, Muffler
17	532 43 75-73	1	Muffler Assembly (Includes hardware)
18	532 43 75-74	1	Gasket, Exhaust Port
19	532 43 75-75	1	Fuel Cap Assembly
20	532 43 75-76	1	Fuel Tank Assembly (Includes hardware)
21	532 43 75-77	1	Service Kit, Fuel Tank (Includes Fuel Hose and Hose Clamps)
22	532 43 75-80	1	Ignition Coil
23	532 43 93-78	1	Cap, Spark Plug
24	532 43 75-81	1	Brake Assembly
25	532 43 75-82	1	Primer Bulb Assembly (Includes Hose and Clips)
26	532 43 75-83	1	Shroud Assembly (Includes hardware)
27	532 43 93-79	1	Spring, Governor
28	532 43 93-80	1	Throttle (Governor) Control Lever Set
29	532 43 93-81	1	Throttle Control Bracket Assembly
30	532 43 93-82	1	Brackets, Fuel Tank (RH and LH)
31	532 43 93-84	1	Blower Housing
32	532 43 93-85	1	Flywheel Assembly (Nuts, Washer and Key)

NOT ILLUSTRATED:

- 532 43 75-84 1 Engine Assembly (Shroud not included)

[Order RV140 engine parts on eBay](#)

REPAIR PARTS

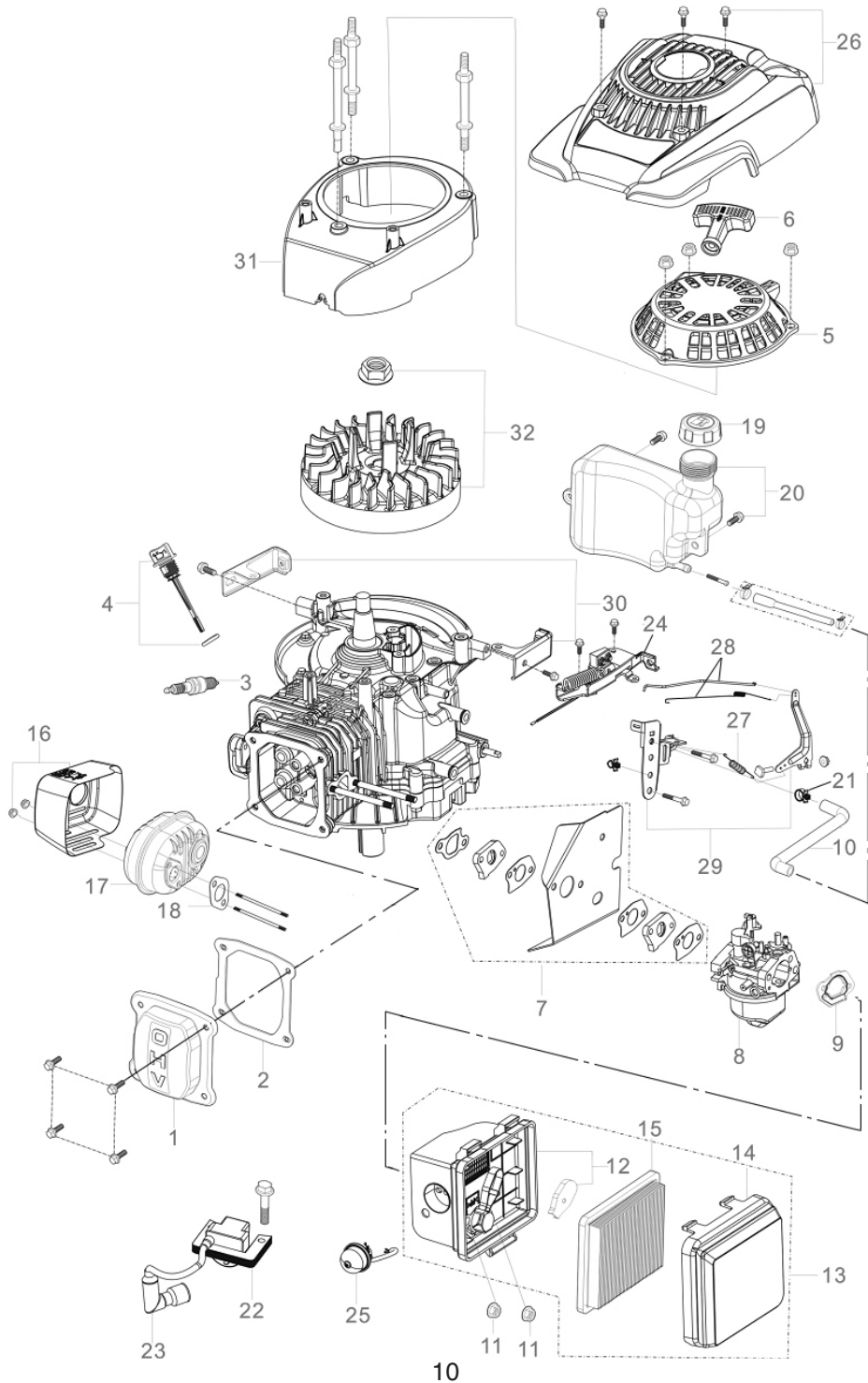

10

MAINTENANCE

- Continue adding small amounts of oil and rechecking the dipstick until it reads full. **DO NOT** overfill, or engine will smoke on startup.
- Always be sure to retighten oil fill cap/dipstick before starting engine.
- Reconnect spark plug wire to spark plug.

IN-LINE FUEL FILTER

The fuel filter should be replaced every 100 hours or twice each season. If fuel filter becomes clogged, obstructing fuel flow to carburetor, replacement is required.

- With engine cool, remove filter and plug fuel line.
- Place new fuel filter in position in fuel line as shown.
- Be sure there are no fuel line leaks and clamps are properly positioned.
- Immediately wipe up any spilled gasoline.

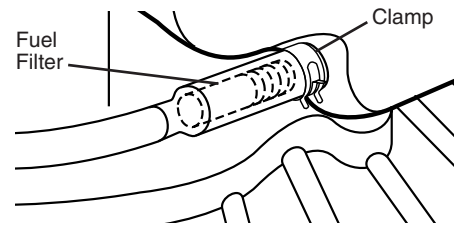

AIR FILTER

Your engine will not run properly and may be damaged by using a dirty air filter. Replace the air filter every 100 hours of operation or every season, whichever occurs first. Service air cleaner more often under dusty conditions.

TO CLEAN AIR FILTER

- Remove cover.
 - Carefully remove cartridge.
 - Clean by gently tapping on a flat surface. If very dirty, replace cartridge.
- CAUTION:** Petroleum solvents, such as kerosene, are not to be used to clean cartridge. They may cause deterioration of the cartridge. Do not oil cartridge. Do not use pressurized air to clean or dry cartridge.
- Install cartridge, then replace cover.

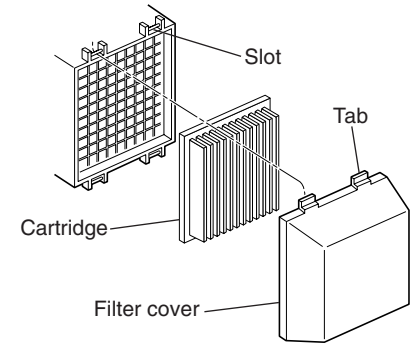

SERVICE AND ADJUSTMENTS

ENGINE

Warranty repairs must be performed by an authorized engine manufacturer's service outlet. Tampering with, removing or altering of any part of the intake, fuel or exhaust system, or emission control system may increase emissions beyond the legal limit and void your warranty.

ENGINE SPEED

Your engine speed has been factory set. Any attempt to increase engine speed may result in personal injury. If you believe that the engine is running too fast or too slow, you can adjust the governor tab as follows:

- Disconnect spark plug wire from spark plug and place wire where it cannot come in contact with plug.
- Start engine as described in the Operation section of this manual.
- Move choke cable from "OPEN" to "RUNNING" position.

- Bend governor tab up for higher engine speed; down a for lower engine speed.
- IMPORTANT:** If you have any questions, lack the tools or professional ability, take your engine to a qualified service center for repair and adjustment.

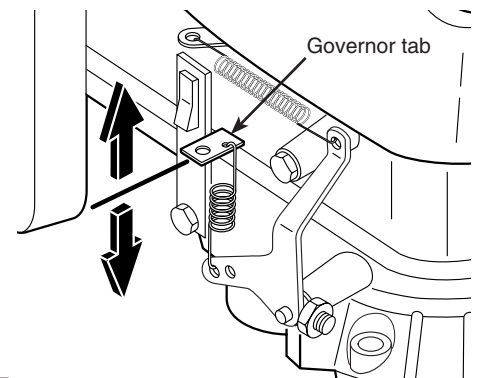

7

TROUBLESHOOTING

TROUBLESHOOTING - See appropriate section in manual unless directed to an authorized Service Center.

PROBLEM	CAUSE	CORRECTION
Does not start	1. Dirty air filter.	1. Clean or replace air filter as shown in the "Maintenance" section of this manual.
	2. Out of fuel.	2. Fill fuel tank as shown in the "Maintenance" section of this manual.
	3. Stale fuel.	3. Empty fuel tank and refill tank with fresh, clean gasoline.
	4. Dirt or water in fuel.	4. Empty fuel tank and refill tank with fresh, clean gasoline.
	5. Spark plug wire is disconnected.	5. Connect wire to spark plug.
	6. Dirty or bad spark plug.	6. Clean or replace spark plug.
	7. Bad spark plug wire.	7. Replace spark plug wire.
	8. Piston ring is worn, broken or sticking.	8. Clean or replace piston ring.
	9. Leaking cylinder gasket.	9. Replace cylinder gasket.
	10. Valves out of adjustment.	10. Adjust valve clearance (see Product Specifications).
	11. Vent in filler cap clogged.	11. Clean filler cap vent.
	12. Carburetor float is sticking or damaged.	12. Clean or replace the carburetor float.
	13. Carburetor jet is clogged or damaged.	13. Clean or replace the carburetor jet.
	14. Control bar in released position.	14. Depress control bar to handle.
	15. Control bar defective.	15. Replace control bar.
Loss of power	1. Dirty air filter.	1. Clean or replace air filter as shown in the "Maintenance" section of this manual.
	2. Dirt or water in fuel.	2. Empty fuel tank and refill tank with fresh, clean gasoline.
	3. Piston ring is worn, broken or sticking.	3. Clean or replace piston ring.
	4. Leaking cylinder gasket.	4. Replace cylinder gasket.
	5. Valves out of adjustment.	5. Adjust valve clearance (see Product Specifications).
	6. Carburetor jet is clogged or damaged.	6. Clean or replace the carburetor jet.
	7. Muffler clogged or damaged.	7. Clean or replace muffler.
	8. Oil level too high.	8. Check oil level as shown in the "Maintenance" section of this manual.
	9. Excessive carbon buildup in combustion chamber.	9. Clean combustion chamber.

TROUBLESHOOTING

TROUBLESHOOTING - See appropriate section in manual unless directed to an authorized Service Center.

PROBLEM	CAUSE	CORRECTION
Engine stops or does not idle smoothly	1. Dirty air filter.	1. Clean or replace air filter as shown in the "Maintenance" section of this manual.
	2. Dirt or water in fuel.	2. Empty fuel tank and refill tank with fresh, clean gasoline.
	3. Dirty or bad spark plug.	3. Clean or replace spark plug.
	4. Excessive carbon buildup in combustion chamber.	4. Clean combustion chamber.
	5. Tie rod head is worn.	5. Replace tie rod.
Engine is overheating	1. Cooling fins clogged.	1. Clean cooling fins.
	2. Oil level too low.	2. Add oil as shown in the "Maintenance" section of this manual.
	3. Engine speed too high.	3. Adjust governor screw as shown in the "Service & Adjustments" section of this manual.
	4. Muffler clogged or damaged.	4. Clean or replace muffler.
Excessive vibration or noise	1. Bent crankshaft, disconnected flywheel or broken piston ring.	1. Contact a qualified service center.
Starter rope hard to pull	1. Engine flywheel brake is on when control bar is released.	1. Depress control bar to upper handle before pulling starter rope.
	2. Bent crankshaft.	2. Contact a qualified service center.
Engine is emitting bluish black smoke	1. Oil level too high.	2. Check oil dipstick. If oil level is over upper mark, drain oil until at recommended level.

TORQUE VALUES

ITEM	SPECIFICATION	TORQUE VALUE
Connecting Rod Bolt	M10	12 N/m (1,2 kg/m)
Cylinder Head Bolt	M12	22 N/m (2,2 kg/m)
Flywheel Nut	M14 x 1.5	73 N/m (7.4 kg/m)
Crankcase Cover Bolt	M8 x 1.5	26 N/m (2,6 kg/m)
Valve Clearance Adjusting Nut	M6 x 0.5	10 N/m (1.0 kg/m)
Valve Rocker Arm Bolt	M8 x 1.25	24 N/m (2.4 kg/m)