

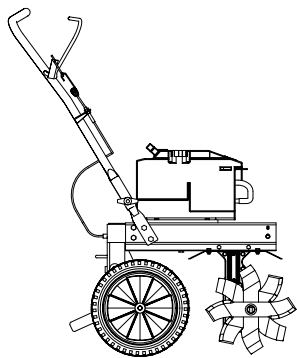

Front Tine Rototiller Operator's Manual

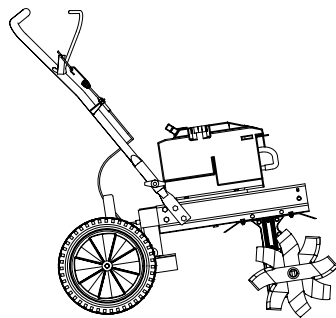

Transport Position



Operating Position

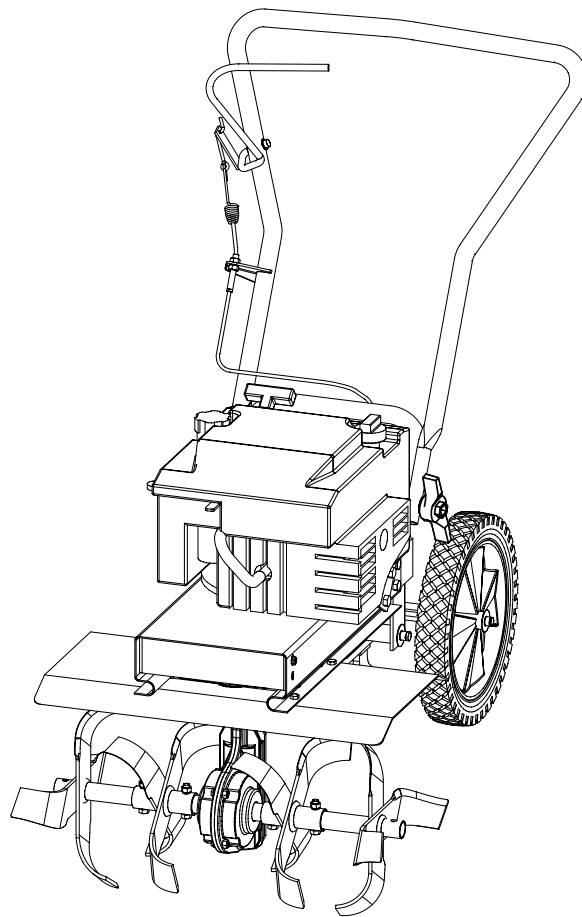

Includes Models

FT6000X92A



MODEL IDENTIFICATION	3	ADJUSTMENTS	12
WARRANTY	4	Belt Tension Adjustment	12
SAFETY RULES	5	Depth Regulator Lever	13
Owner's Responsibility	5	OPERATION	14
General	5	Pre-Start Inspection	14
Preparation	5	Start-up	14
Operation	6	Shutting Down	15
Maintenance and Storage	6	Tilling	15
Safety Decals	7	NORMAL CARE	16
FEATURES	8	Schedule	16
UNPACKING AND ASSEMBLY	9	Servicing The Rototiller	17
Unpack Tiller	9	STORAGE	20
Install the Depth Regulator Lever	10	Prepare For Storage	20
Fill Engine Crankcase	10	TROUBLESHOOTING AND REPAIR	21
CONTROLS	11	Troubleshooting Guide	21
Drive Safety Control Lever	11	Parts Listings	22
		Notes	26

MODEL IDENTIFICATION

Record your model number, manufacturer number and serial number in the space provided for easy reference. The model and manufacturer numbers can be found on the unit I.D. plate located on the unit's left engine mount. Refer to the Engine Owner's Manual for location of engine serial number.

ROTOTILLER REFERENCE DATA	
Model Description/Number	
M/N (Manufacturer's Number)	S/N (Serial Number)
Dealer Name	Date Purchased
Engine Make/Model	Engine ID/Serial Number

 WARNING

You must read, understand and comply with all safety and operating instructions in this manual before attempting to setup and operate your rototiller.

Failure to comply with all safety and operating instructions can result in loss of machine control, serious personal injury to you and/or bystanders, and risk of equipment and property damage. The triangle in the text signifies important cautions or warnings which must be followed.

 WARNING

Engine exhaust from this product contains chemicals known, in certain quantities, to cause cancer, birth defects, or other reproductive harm.

WARRANTY

Thank You . . .

for purchasing an Murray front tine rototiller. We guarantee that this front tine rototiller conforms to applicable North American safety standards, and have worked to ensure that it will meet your exacting standards for usability and durability. With proper care, your rototiller will provide many years of service.

Please take time to read this manual carefully to learn how to operate and service your rototiller correctly. Failure to do so could result in personal injury or equipment damage. This manual should be considered a permanent part of your rototiller. Congratulations on your investment in quality.

MURRAY, INC. Two Year Limited Warranty TILLER PRODUCT 2 YEAR WARRANTY

Murray, Inc. warrants to the original purchaser that this unit shall be free from defects in material and workmanship under normal use and service for a period of Two (2) Years from the date of purchase; however, this warranty does not cover Normal Wear Parts (except as noted below) or engines, accessories, transmissions, and transaxles supplied through other companies that furnish their own warranties and provide service through their authorized field service facilities. For additional information, see the warranties covering these particular parts. If you are uncertain whether your unit contains or is equipped with one or more of these parts, consult your dealer prior to purchase. Subject to the terms and conditions noted in this Limited Warranty, we shall, at our option, repair or replace at no cost to the original purchaser any part covered by this Limited Warranty during the applicable warranty period.

Normal Wear Parts are defined as belts, tines, pulley adapters, wheels, and pneumatic tires. These parts are warranted to be free from defects in material and workmanship as delivered with the product. Any claim for repair or replacement of Normal Wear Parts must be made within thirty (30) days of the date of purchase. No claims involving damage caused from material use, abuse or misuse will be honored.

This **Murray, Inc. Two (2) Year Limited Warranty** is your exclusive remedy; however, this warranty is void or does not apply to any unit that has been tampered with, altered, misused, abused or used for rental or other commercial and/or professional (non-homeowner) uses. Your warranty does not cover minor mechanical adjustments which are not due to any defect in material or workmanship. For assistance in making such adjustments, consult your Instruction Book.

To make a claim under this **Murray, Inc. Two (2) Year Limited Warranty**, return the unit (or if authorized in advance, the defective part) along with your proof of purchase to an Authorized Service Center near you. To locate the nearest Authorized Service Center, call the Central Parts Distributor for your area shown in the list provided with your unit or check the Yellow Page listings in your local telephone directory. If you return the entire unit, we will repair the unit. If we authorize the return of the defective part only, we will either replace or repair the part. In the case of a defect in a transmission or differential (as distinguished from a transaxle), the entire transmission or differential must be returned since they do not include user serviceable parts.

This **Murray, Inc. Two (2) Year Limited Warranty** gives you specific legal rights, and you may also have other rights which vary from state to state. **This Limited Warranty is given in lieu of all other expressed and implied warranties including the implied warranty of merchantability and warranty of fitness for a particular purpose.** If you need additional information on this written warranty or assistance in obtaining service, write or call:

MURRAY, INC.

Outdoor Power Equipment
Customer Service Department
P.O. Box 268; Brentwood, Tennessee 37024-0268
1-800-251-8007

OWNER'S RESPONSIBILITY

Safe and effective use of the rototiller is the owner's responsibility.

1. Read and follow all safety instructions.
2. Maintain the tiller according to directions and schedule included.
3. Ensure that anyone who uses the tiller is familiar with all controls and safety precautions.

GENERAL

 The Safety Alert symbol shown here is used to alert you to important safety information that must be read, fully understood, and followed at **all** times when handling, transporting, operating, servicing, or storing your rototiller unit.

Each safety alert symbol is followed by a "signal word" that advised you of the relative intensity, or level, of the hazard the safety alert instructions pertain to.

The following list of signal words is being provided to help you understand the intensity levels associated with each signal word used in this manual.

DANGER

The signal word "DANGER" is used when a serious injury or fatality will result if the safety instructions that follow this signal word are not obeyed.

WARNING

The signal word "WARNING" is used when a serious injury or fatality could result if the safety instructions that follow this signal word are not obeyed.

CAUTION

The signal word "CAUTION" is used when personal injury, or property or equipment damage could result if the safety instructions that follow this signal word are not obeyed.

IMPORTANT

Provides helpful information for proper assembly, operation, or maintenance of your rototiller.

- CAREFULLY READ THIS MANUAL AND FOLLOW ALL INSTRUCTIONS.
- Be familiar with all controls before operating the tiller. Your tiller is equipped with a safety device that enables you to stop the tines quickly in an emergency. Learn how the drive safety control lever works and how to control the tiller at all times.
- Never allow children to operate the tiller. Keep small children away from the area being tilled. Do not allow adults to operate the tiller without proper instruction.
- Do not operate the tiller under the influence of alcohol or drugs.

PREPARATION

- Dress appropriately when operating the tiller. Always wear sturdy footwear. Never wear sandals, sneakers, or open shoes, and never operate the tiller with bare feet. Do not wear loose clothing that might get caught in moving parts.
- Carefully inspect the area to be tilled, and remove all foreign objects. Do not till above underground water lines, gas lines, electric cables, or pipes. Do not operate the tiller in soil with large rocks and foreign objects which can damage the equipment.
- Disengage drive safety control lever before starting the engine.
- Handle fuel with care; it is highly flammable.
 - a. Use an approved fuel container.
 - b. Never add fuel to a running engine or hot engine.
 - c. Fill fuel tank outdoors with extreme care. Never fill fuel tank indoors.
 - d. Replace gasoline cap securely and clean up spilled fuel before restarting.
- Never attempt to make any adjustments while the engine is running.

IMPORTANT

Engine is shipped from factory without oil. You must add engine oil before starting engine.

SAFETY RULES

OPERATION

- Never operate the tiller without guards, covers, and hoods in place.
- Keep hands, feet, and clothing away from rotating parts. Keep clear of tiller tines at all times.
- Tines rotate when tiller is engaged in **forward**-- in **forward**, tines rotate when the drive safety control lever is pulled down. Releasing the drive safety control lever to **neutral** stops the tines.
- Exercise extreme caution when operating on or crossing gravel drives, walks, or roads. Stay alert for hidden hazards or traffic.
- After striking a foreign object, stop the engine, remove the wire from the spark plug and secure, thoroughly inspect the tiller for any damage, and repair the damage before restarting and operating the tiller.
- If vegetation clogs the tines, **STOP THE ENGINE AND DISCONNECT THE SPARK PLUG WIRE** before removing vegetation by hand.
- Engine muffler will be hot from operation. Do not touch it with bare skin or a severe burn may result.
- If the unit should start to vibrate abnormally, stop the engine and check immediately for the cause. Vibration is generally a warning of trouble.
- Do not run the engine indoors; exhaust fumes are dangerous.
- Do not overload the machine capacity by attempting to till too deep at too fast a rate.

- Never allow bystanders near the unit.
- Never operate the tiller without good visibility or light.
- Take all possible precautions when leaving the machine unattended. Disengage drive control lever, stop the engine, wait for all moving parts to stop, and make certain guards and shields are in place.
- When leaving the operating position for any reason:
 - shut off the engine.
 - wait for all moving parts to stop.

MAINTENANCE AND STORAGE

- Keep machine, attachments, and accessories in safe working condition.
- Check shear bolts, engine mounting bolts, and other bolts at frequent intervals for proper tightness to be sure the equipment is in safe working condition.
- To prevent accidental starting, always disconnect the spark plug wire from the spark plug before performing tiller maintenance.
- Never run the engine indoors. Exhaust fumes are deadly.
- Always allow muffler to cool before filling fuel tank.
- Never store equipment with gasoline in the tank inside a closed building where fumes may reach an open flame or spark. Allow the engine to cool before storing in any building.
- Always refer to the operator's guide instructions for important details if the tiller is to be stored for an extended period.

SAFETY DECALS

This rototiller unit has been designed and manufactured to provide you with the safety and reliability you would expect from an industry leader in outdoor power equipment manufacturing.

Although reading this manual and the safety instructions it contains will provide you with the necessary basic knowledge to operated this equipment safely and effectively, we have placed several safety labels on the tiller to remind you of this important information while you are operating the unit.

These important safety labels are illustrated below, and are shown here to help familiarize you with the location and content of the safety messages you will see as you perform normal tilling operations. Please review these labels now, and if you have any questions regarding their meaning or how to comply with these instructions, reread the complete safety instruction text on the preceding pages, or contact your local dealer.

Should any of these labels become unreadable because of being worn, faded, or otherwise damaged during the use of your tiller, please use the part number information provided to order a replacement label from your local authorized dealer.

These labels are easily applied, and will act as a constant visual reminder to you, and others who may use the equipment, to follow the safety instructions necessary for safe, effective operation of your rototiller.

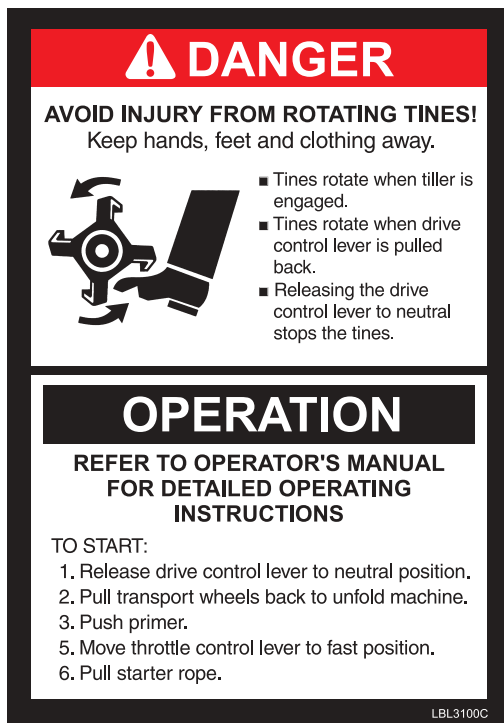

**Part No. 48x5318
TINES DANGER/OPERATION
Hood Decal**



**Part No. 48x5410
HOOD WARNING
Hood Decal**



**Part No. 48x5322
WARNING
Belt Cover Decal**



**Part No. 48x5321
WARNING
Pivot Mount Decal**



**Part No. 48x5320
CLUTCH ENGAGE
Handlebar Decal**

FEATURES

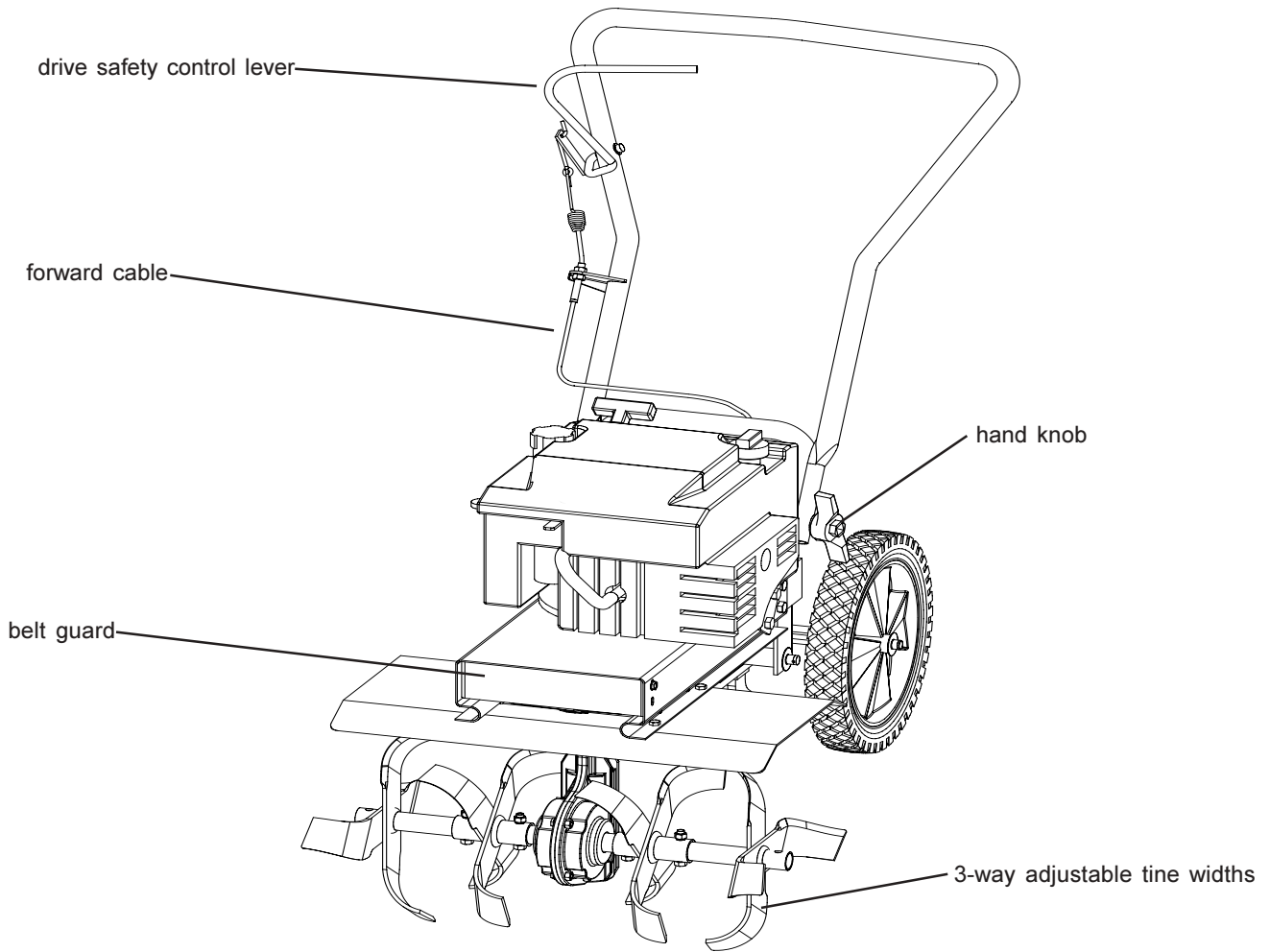

The *advantage* of the **MURRAY gear drive rototiller** over other front tine tillers, is the exclusive unfolding and flexible drag bar. This gives the **Murray gear drive tiller** its stability and its versatility. For easy transport, fold the wheels under the engine. During operation, the wheels unfold back and the drag bar folds down. The long length between the tines and the depth regulator level make this the most comfortable front tine tiller on the market.

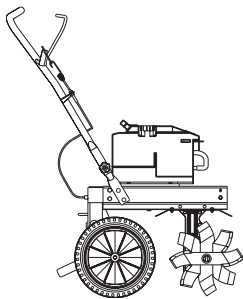

Transport Position

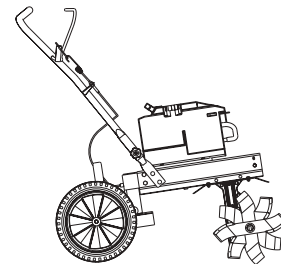

Operating Position

UNPACK TILLER

1. Open top of carton and remove handlebar assembly.



CAUTION

Do not try to lift the rototiller from the carton.

2. Cut open end of carton and remove machine:
 - a. Tines are pre-assembled at 21" width. Sharp edge of tine will be away from operator at top or face down at front of machine. (Figure 2)
 - b. Outside tines have two positions- wide 21" & narrow 16". For narrow width - assemble with short side of tine holder pipe towards center of machine. For 11" width, remove outside tine sets. (Figure 1)
 - c. For wide width - move left tine to right side and right to left side. Assemble with long half of tine pipe towards machine. (Figure 2)
 - d. Remove two (2) hand knobs & bolts and slide top handle of handlebar over lower loop. Put 5/16-18 x 1-3/4" bolts thru both holes from inside out, and tighten with hand knobs.
 - e. Check upper and lower jam nuts for tightness. See Figure 4, Belt Tension Adjustment.
 - f. Add and check engine oil.

IMPORTANT

The right and left sides of your rototiller are determined from the operating position as you face the direction of forward travel.

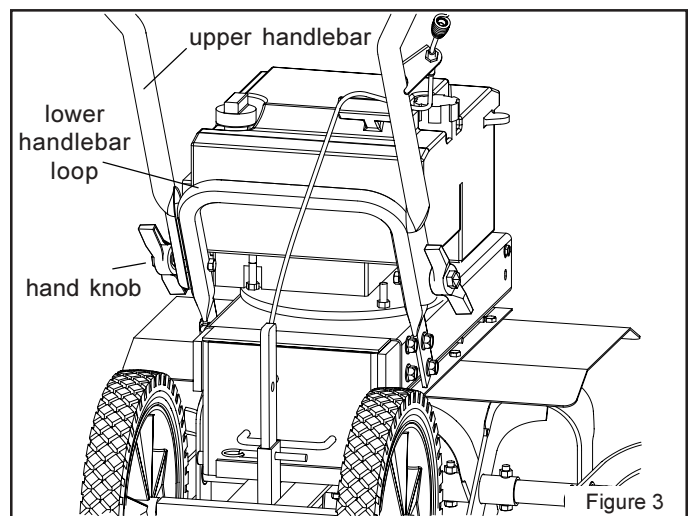
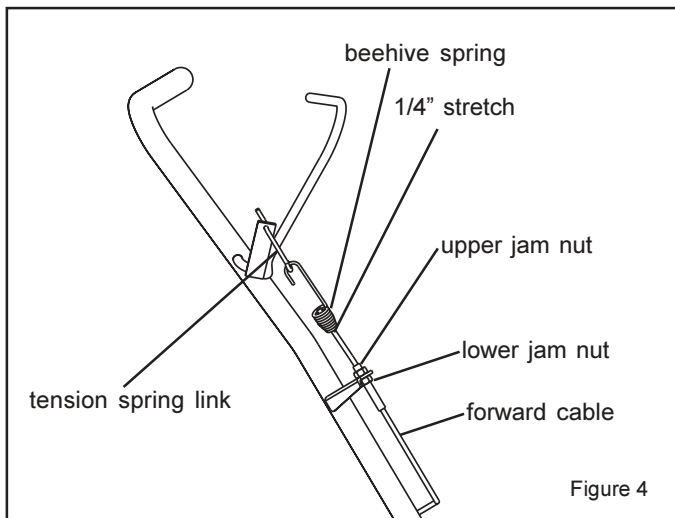
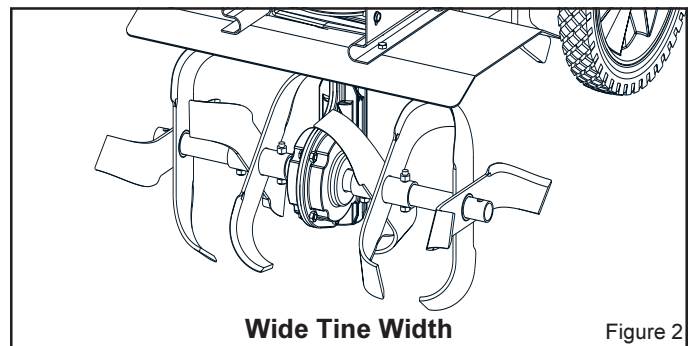
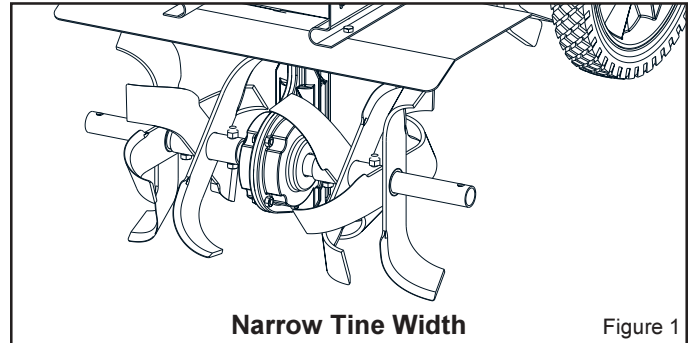
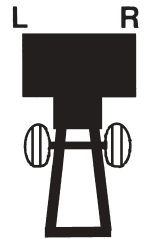

UNPACKING AND ASSEMBLY

INSTALL THE DEPTH REGULATOR LEVER

1. Install the depth regulator lever through hole in bracket from the bottom up with curve to rear of unit and secure with detent pin.

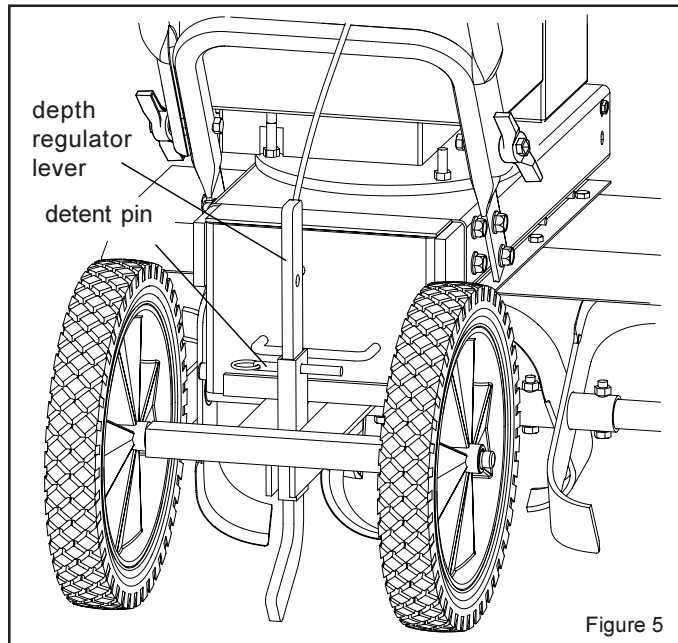

FILL ENGINE CRANKCASE



Engine is shipped from factory without oil. You must add engine oil before starting engine.

1. Add oil according to engine manual. **Do not overfill.** Use a clean, high quality detergent oil. Container must be marked A.P.I. Service SF - SJ. Use no special additives with recommended oils. **Do not mix oil with gasoline.** Oil level must be full. Check the oil level by removing the dipstick. Oil level should be at FULL line on dipstick.
2. Always check oil level before starting engine. Refer to engine manual for capacity and type of oil to use.

DRIVE SAFETY CONTROL LEVER

Engage tines into forward, releasing returns machine to neutral.

Pulling down on drive safety control lever engages the tines. Releasing the drive safety control lever disengages the tines to a neutral position.

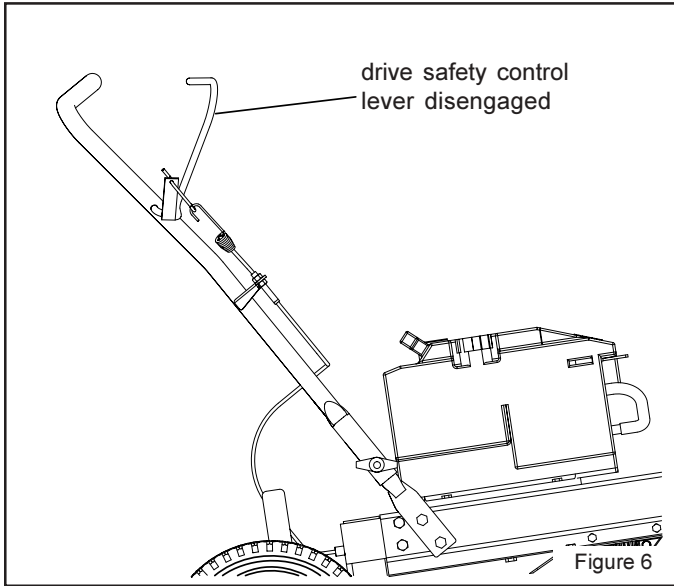

⚠ CAUTION

This information is provided here only to introduce the controls. **DO NOT START THE ENGINE AT THIS TIME.** Starting and operating instructions are given on page 11. Please read this section and all operating and safety instructions before starting your tiller.

⚠ WARNING

Engine should be off before adjusting any controls.

⚠ CAUTION

- As a safety precaution, the drive safety control levers will not lock in the forward position.
- To stop the wheels and tines at any time release the drive safety control levers.

⚠ WARNING

Extreme caution should be used when operating rototiller in the forward direction.

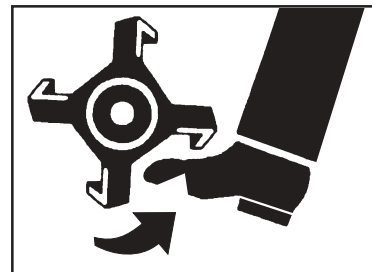

ADJUSTMENTS

BELT TENSION ADJUSTMENT

Proper belt tension is critical to good performance. After half hour of operation, all cables may have to be adjusted due to initial stretch. Thereafter, check tension after every 2 hours of operation.

To increase belt tension:

1. Loosen upper jam nut. Turn nut up cable in 1/8" increments.
2. Tighten lower jam nut.
3. Check adjustment.

This procedure can be repeated until conduit adjustment bolts have no more adjustment left. If no more adjustment can be made, belt may have to be replaced.

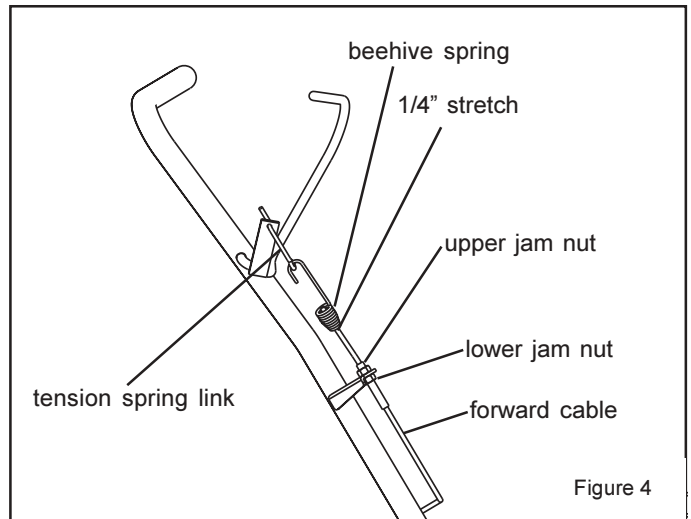

DEPTH REGULATOR LEVER

Tilling depth is controlled by the height of the depth regulator lever.

To adjust tilling depth:

1. Remove detent pin.
2. Raise the depth regulator lever to position tines at chosen tilling depth.
3. Align hole in depth regulator lever with hole in depth regulator bracket and replace detent pin.

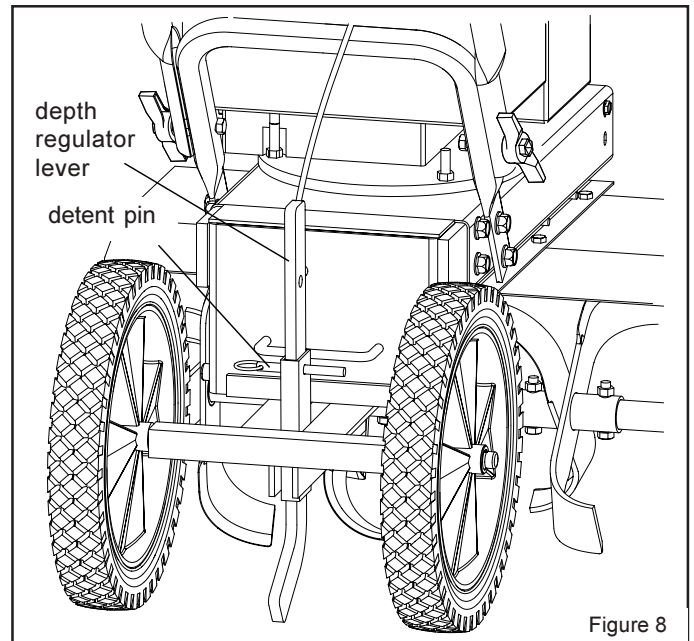

Figure 8



CAUTION

Do not adjust tilling depth unless drive safety control lever is released to the neutral position.

OPERATION

PRE-START INSPECTION

1. Make sure all safety guards are in place and all nuts and bolts are secure.
2. Check oil level in engine crankcase. See your engine manual for procedure and specifications.
3. Inspect air cleaner for cleanliness. See your engine manual for procedure.
4. Check the fuel supply. Fill the fuel tank no closer than 1 inch from top of tank to provide space for expansion. See your engine manual for fuel recommendations.
5. Be sure spark plug is tightened securely and spark plug wire is attached.
6. Check depth regulator lever position.

CAUTION

Please do not start your tiller until you have read the Manual that came with your engine, and the sections in this manual titled Controls, Adjustments and Safety. If you have read these, follow the steps below to start your tiller. Always perform this pre-start checklist before starting the engine.

WARNING

Gasoline is highly flammable and must be handled with care. Never fill the tank when the engine is hot or running. Always move outdoors to fill the tank.



Engine is shipped from factory without oil. You must add engine oil before starting engine.

START-UP

The controls required to start and run the rototiller are located on the engine and are marked "Choke" and "Throttle".

A more detailed description of engine operation and all related precautions and procedures can be found in the engine manufacturer's manual that accompanies each tiller.

Cold Starts

1. Move choke lever to full choke position.
2. Move throttle lever to "start".
3. When starting, operator should place free hand where indicated and start the engine from the operator position.
4. Pull starting rope out slowly one time and allow to return normally.
5. Pull starting rope out rapidly, and allow rope to return normally.
6. When engine starts, gradually move choke lever to "no choke" position and increase throttle speed.

Restarting A Warm Engine

Restarting an engine that is already warm from previous running does not normally require use of the choke.

1. Move throttle lever to "start" position.
2. When starting, operator should place free hand where indicated and start the engine from the operator position.
3. Pull starting rope out rapidly until engine starts. Allow rope to return normally.
4. Adjust throttle speed to "high" for best tiller action.

Idle Speed

Use the "low" position on the throttle lever to reduce stress on the engine when tilling is not being performed. Lowering the engine speed to "idle" the engine will help extend the life of the motor, as well as conserve fuel and reduce the noise level of the equipment.

Operating Speed

For normal tilling, set the throttle lever to "fast".

 **DANGER**

Always keep hands and feet clear of rotating machine parts.

 **WARNING**

Temperature of muffler and near by areas may exceed 150° F. Avoid these areas.

 **WARNING**

Do not move choke control to **CHOKE** to stop engine. Backfire or engine damage may occur.

SHUTTING DOWN

 **DANGER**

Engine and surrounding parts become extremely hot during normal use, and will cause serious burn injuries if touched before the engine has cooled.

Allow engine to cool completely before touching these hot surfaces.

IMPORTANT

To stop the engine at any time, move throttle control to the off position. To stop tines at any time, release drive safety control lever to the neutral position.

TILLING

1. Adjust the depth regulator lever to desired tilling depth.

NOTE: Raise depth regulator lever up one hole at a time, testing tiller operation after each raise. Raising depth regulator lever too high can result in loss of control of tiller!

2. Move the throttle control to *fast*.

3. Place the tiller in *forward* by pushing down on the drive control lever--this will engage the tines.

 **CAUTION**

To stop the tines at any time, release drive safety control lever to the neutral position.

 **CAUTION**

Always release drive safety control lever to the neutral position before adjusting the depth regulator lever.

NORMAL CARE

SCHEDULE

Your rototiller has been designed and produced by the industry's leading manufacturer of outdoor power equipment to provide you with years of reliable operation.

Keeping your tiller in top running condition will prolong its life, and help you obtain optimum performance whenever you wish to till your garden.

Please read this normal care schedule, and observe these recommended care operating intervals to extend the life of your unit.

<i>Maintenance Operation</i>	<i>Page</i>	<i>Before Each Use</i>	<i>50 hrs or Every Season</i>
<i>Check belt tension</i>	<i>17</i>	<i>X</i>	
<i>Change belt</i>	<i>17</i>		<i>X</i>
<i>Engine maintenance</i>	<i>18</i>	<i>X</i>	<i>X</i>
<i>Check or fill engine oil</i>	<i>18, EM</i>	<i>X</i>	<i>2</i>
<i>Check tiller transmission grease</i>	<i>19</i>	<i>X</i>	
<i>Clean tine axle shaft</i>	<i>19</i>	<i>X</i>	
<i>Check throttle control adjustment</i>	<i>EM</i>		<i>1</i>

EM = See engine manual

- 1** Adjust throttle control after first 3 hours of operation or if engine is hard to start or run-on occurs.
- 2** Change oil after first 5-8 hours of use, then after every 50 hours or every season. Change oil every 25 hours when operating under heavy load or in high temperatures.

SERVICING THE ROTOTILLER

General

The following information will help you make the necessary checks and perform the procedures required to follow the normal care recommendations made for your rototiller unit.

If you prefer, your local authorized service dealer can make these checks and perform the required procedures for you.

Check Belt Tension

Belt tension may decrease over time. It must be adjusted within the first half hour of operation, and checked after every two hours of operation. Proper adjustment will assure long belt life. Too much or too little belt tension will cause premature belt failure. To check and adjust the forward belt tension:

1. Turn off engine. Engine must be cool.
2. Remove spark plug wire from spark plug and secure.
3. With drive safety control lever in the neutral position, measure length of spring when compressed.
4. Pull down on drive safety control lever and measure length of spring when stretched out. Ideal length would be 1/4" longer.

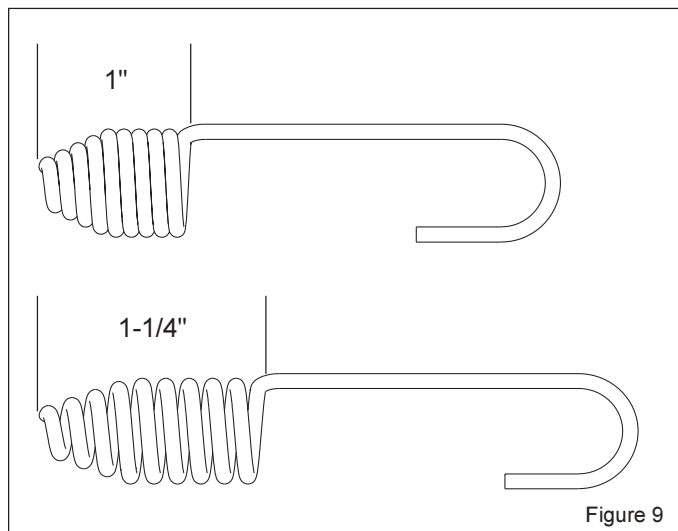

Figure 9

WARNING

Check forward belt tension regularly. Too much or too little tension will cause premature belt failure.

Belt Replacement

1. Turn off engine. Engine must be cool.
2. Remove spark plug wire from spark plug and secure.
3. Remove belt guard. (Fig. 11)
4. Remove dirt shield from bottom of tiller. (Fig. 10)
remove the belt from the engine pulley:

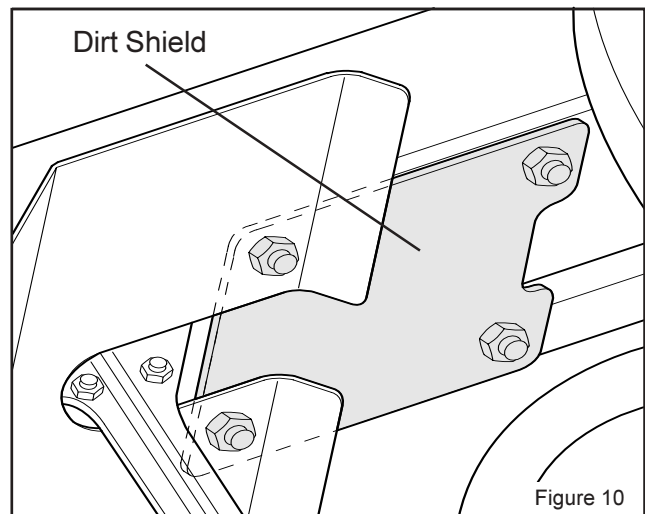

Figure 10

- force the belt down from engine pulley and slowly rotate pulley by pulling the starter cord.
- remove the belt from transmission pulley.
- push the belt forward and out front of machine.

install new belt:

- place new belt onto transmission pulley.
 - force belt up onto engine pulley while rotating pulley with engine starter cord.
5. Replace belt guard and dirt shield.
 6. Attach spark plug wire.

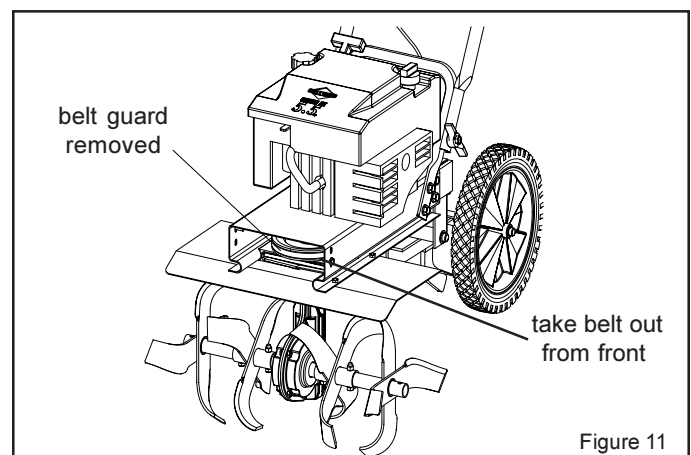

Figure 11

NORMAL CARE

CAUTION

Do not operate tiller before reading the engine manual provided in the parts packet.

WARNING

Temperature of muffler and near by areas may exceed 150° F. Avoid these areas.

IMPORTANT

Engine can overheat and become damaged if debris blocks the cooling system or rotating screen.

IMPORTANT

Never run engine without complete air cleaner installed on engine.

Engine Maintenance

Refer to the engine manual included in your parts packet for information on engine maintenance. Your engine manual provides detailed information and a maintenance schedule for performing the following tasks:

1. Check oil level before each use or after every 8 hours of operation.
2. Change oil after first 5-8 hours of operation. Change oil while engine is warm. Refill with new oil of recommended grade.
4. Check spark plug yearly or every 100 hours of operation.
5. Service air cleaner.
6. Keep engine and parts clean.
7. Check engine and equipment often for loose nuts and bolts, keep these items tightened.

IMPORTANT

Engine is shipped from factory without oil. You must add engine oil before starting engine.

Check or Fill Engine Oil

1. Add oil according to engine manual. **Do not overfill.** Use a clean, high quality detergent oil. Container must be marked A.P.I. Service SF - SJ. Use no special additives with recommended oils. **Do not mix oil with gasoline.** Oil level must be full. Check the oil level by removing the dipstick. Oil level should be at FULL line on dipstick.
2. Always check oil level before starting engine. Refer to engine manual for capacity and type of oil to use.

Change Engine Oil

1. Remove the fasteners that secure the dirt shield at the bottom of the tiller.
2. Take off the dirt shield and you can see the oil drain.
3. Refer to the engine manual for how to change oil.

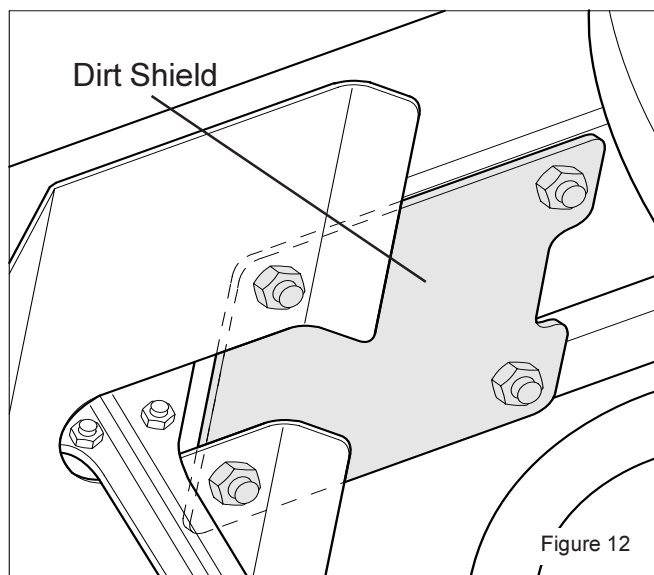

Check Tiller Transmission Grease

IMPORTANT

Tiller transmission is shipped from factory with the proper amount of grease.

To add grease, remove both high and low grease ports. Inject grease in bottom until you see some at top hole, transmission is now full.

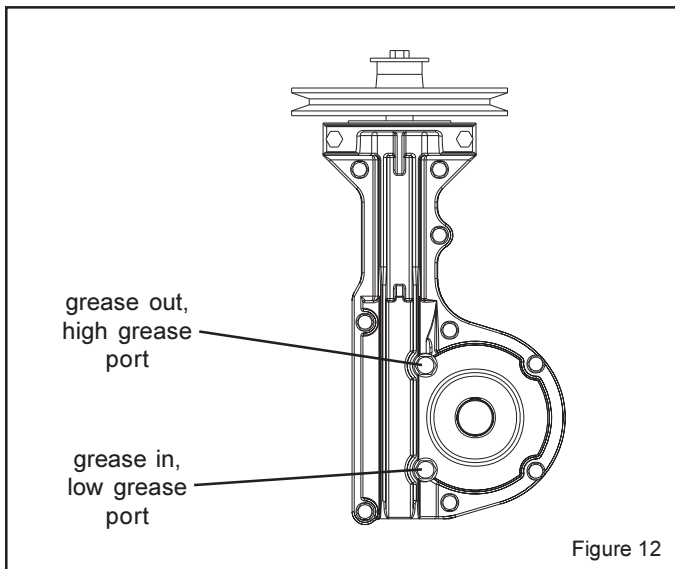

Clean Tine Axle Shaft

1. Turn off engine. Engine must be cool.
2. Remove spark plug wire from spark plug and secure.
3. Remove all vegetation, string, wire, and other material that may have accumulated on the axle between the inside set of tines and the seal on the transmission housing.
4. Replace spark plug wire.

STORAGE

PREPARE FOR STORAGE

Follow the steps below to prepare your tiller for storage. Read your engine manual for detailed instructions on preparing the engine for storage.

1. Protect wheels and axles from rust:
 - Coat the axles lightly with axle grease.
2. Run with gas stabilizer in fuel.
3. Drain the fuel tank. Run the engine until it stops.
4. While engine is still warm, drain the oil from the engine. Refill with fresh oil of the recommended grade.
5. Remove spark plug, pour one-half ounce of clean engine oil into cylinder. Pull starter handle slowly several times to distribute oil. Replace spark plug.
6. Clean entire tiller.
7. Store your tiller in a clean, dry building.

 **CAUTION**

Do not store tiller in a non-ventilated area where fuel fumes may reach flame, sparks, pilot lights or an ignited object. Drain fuel outdoors away from any ignition sources. Use only approved fuel containers.

TROUBLESHOOTING GUIDE

While normal care and routine maintenance will extend the life of your rototiller, prolonged or constant use may eventually require that service be performed to allow it to continue operating properly. The troubleshooting guide below lists the most common problems, causes and remedies.



CAUTION

Practice safety at all times. Engine must be turned off and allowed to cool, and spark plug wire must be disconnected and secured before attempting any maintenance or repair.

PROBLEM	REMEDY/ACTION
Engine will not start	<ul style="list-style-type: none"> · Connect spark plug wire to spark plug · Throttle must be positioned at choke for a cold start
Engine runs rough, floods during operation	<ul style="list-style-type: none"> · Clean or replace air cleaner
Engine is hard to start	<ul style="list-style-type: none"> · Drain old fuel and replace with fresh. Use gas stabilizer at end of season · Make sure spark plug wire is securely attached to spark plug · Drive control safety lever must be released to neutral to start the engine
Engine misses or lacks power	<ul style="list-style-type: none"> · Clean or replace air cleaner · Improper carburetor adjustment, take to authorized engine service center · Replace spark plug and adjust gap · Drain and refill gas tank and carburetor
Engine will not stop when throttle control is positioned at stop	<ul style="list-style-type: none"> · See engine manual to check and adjust throttle linkage
Tiller moves forward during starting	<ul style="list-style-type: none"> · Drive safety control lever must be released to neutral to start the engine
Tiller is difficult to control when tilling (machine jumps or lurches forward)	<ul style="list-style-type: none"> · Raise the tines for shallower tilling by raising the depth regulator lever, see page 10 · Lower engine speed in hard ground
Belts squeal in neutral	<ul style="list-style-type: none"> · Adjust belt guide: <ul style="list-style-type: none"> - turn engine off and allow muffler to cool - disconnect spark plug wire from spark plug - remove the dirt shield - pull down on drive safety control lever - manually bend belt guide so there is 1/16 inch or less clearance between belt guide and belt - replace the dirt shield - replace spark plug wire
Belts squeal in forward operation	<ul style="list-style-type: none"> · Turn engine off and allow muffler to cool · Disconnect spark plug wire from spark plug · Release drive safety control lever to neutral · Adjust engage cable · Replace spark plug wire

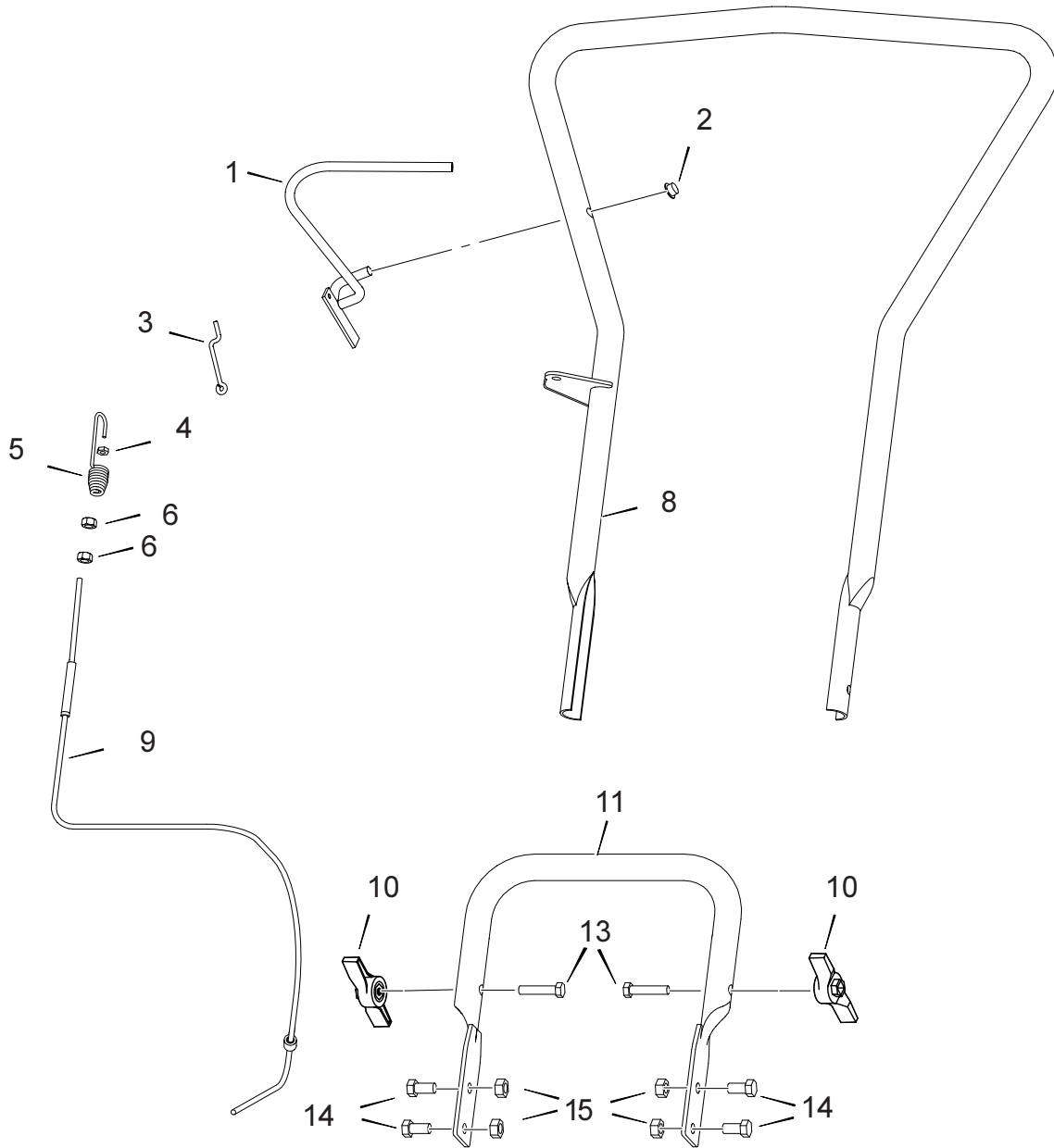

<u>KEY NO.</u>	<u>PART #</u>	<u>DESCRIPTION</u>
1	AR3262E701	FRONT TINE DRIVE LEVER, WELDED
2	028X23	PUSH CAP, 3/8" Dia.
3	AR3261	FRONT TINE TENSION SPRING LINK
4	15x146	NUT-Nyloc, #10-24
5	AR53530	SPRING-Bee Hive, Forward Cable Adjust
6	15x147	NUT-Jam, 5/16"-24
8	7401038	TOP HANDLE ASSEMBLY
9	AR3108A	CABLE ASSEMBLY WITH FERREL
10	094068	KNOB - Wing
11	AR3264E201	BOTTOM HANDLE
13	315288	BOLT 5/16'-18 UNC X 1.75 CURVED HD
14	01x137	BOLT-Hex Hd, 3/8"-16 x 1.00", Grade 5
15	015X84	NUT-Hex, 3/8"-16

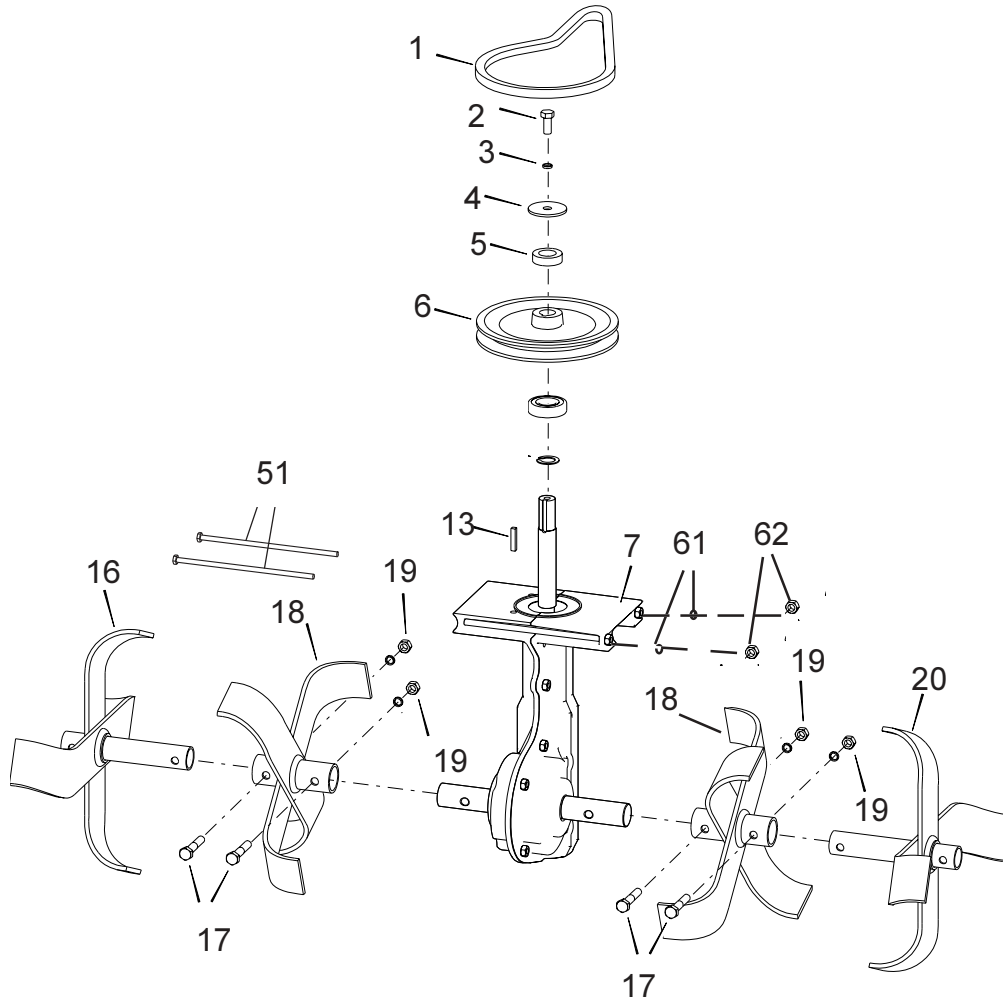

<u>KEY NO.</u>	<u>PART #</u>	<u>DESCRIPTION</u>
1	37X138	BELT-Forward
2	001X64	CAPSCREW-Hex Hd, 5/16-24 x 3/4"
3	018X15	LOCKWASHER-Spring, 5/16"
4	17x146	WASHER, .34 ID X 1.2X 11GATHK
5	AR746	SPACER, 11/16" ID x 3/8" THK
6	AR3179	TRANSMISSION PULLEY
7	ARM1000	TRANSMISSION ASSEMBLY
13	2001022	KEY-Square, 3/16" x 3/4"
16	AR3323E701	TINE SET-Outside Right
17	001X75	BOLT-Hex Hd, 5/16-18 x 1-3/4
18	AR3324E701	TINE SET-Inside
19	015X88	NUT-Biway Lock, 5/16-18
20	AR3326E701	TINE SET-Outside Left
51	01X199	BOLT-Hx Hd, 1/4-20 x 7-1/2"
61	018X32	LOCKWASHER - Spring .25"
62	15X116	NUT - .25-20 HEX NYLOCK B2

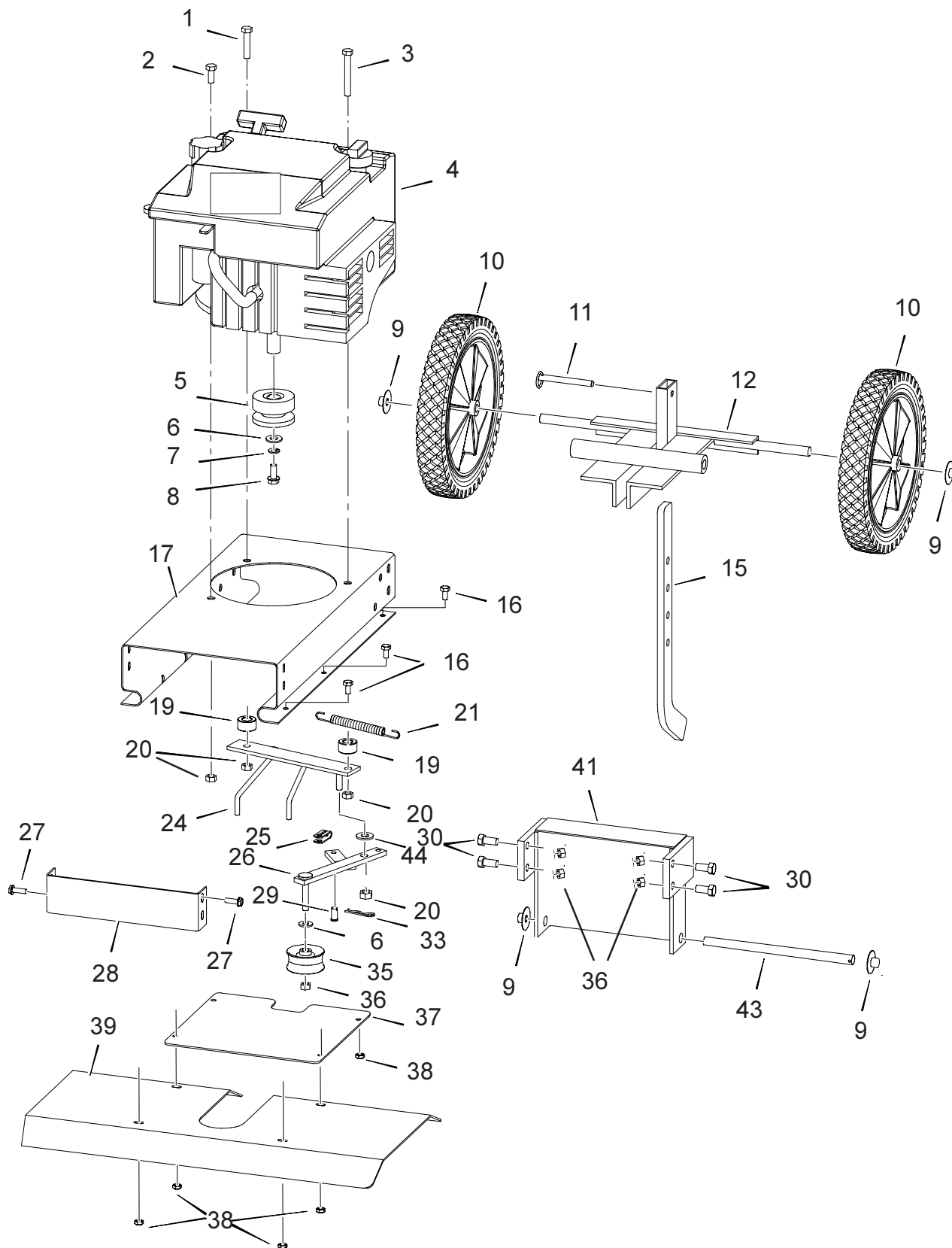

<u>KEY NO.</u>	<u>PART #</u>	<u>DESCRIPTION</u>
1	01X175	BOLT-Hex Hd, 5/16-18 x 2"
2	01X139	BOLT-Hex Hd, 5/16-18 x 1-1/4"
3	01X198	BOLT-Hex Hd, 5/16-18 x 3-1/4"
4	-----	ENGINE*
5	1901051	PULLEY-1 -Drive, 7/8" ID
6	17X124	WASHER, .406 ID x .812 OD, Eng. Pulley
7	018X31	LOCKWASHER-Spring, 3/8"
8	01X194	3/8-24 x 1.75 BES
9	028X22	PUSH NUT, 1/2" Dia
10	AR1714250	WHEEL & TIRE ASSEMBLY
11	1001701	DETENT PIN, 5/16"
12	AR3266E201	DRAG BAR MOUNT
15	AR3157E701	DEPTH REGULATOR LEVER
16	01X100	BOLT-HHCS, 1/4-20 x 1/2"
17	AR3130AE201	FRAME-Engine Mount
19	AR744	SPACER
20	015X88	HEX FLG, NUT, 5/16-18
21	AR1407	SPRING-Idler Arm
24	AR3182A Z	BELT GUIDE & MOUNT
25	AR53596 Z	CABLE YOKE
26	AR3360 Z	IDLER ARM-Forward
27	26X263	SCREW-Sheet Metal, .25-20X.59
28	AR3237E201	FRONT BELT COVER
29	29X107	LINK PIN
30	01X137	BOLT-HEX HD, 3/8-16 x .1.00", Grade 5
33	030X20	COTTER PIN
35	50793	PULLEY-Forward Idler
36	015X84	NUT-Hex flange, 3/8-16
37	1901049E201	DIRT SHIELD
38	15X116	NUT-Nyloc, 1/4"
39	7401039	SHIELD ASSEMBLY
41	7401040	REAR COVER ASSEMBLY
43	AR3149 Z	WHEEL SHAFT, 1/2" Hinge
44	017X48	Washer, .390 ID X .750OD X 13 GATHK

* Parts are available from an Authorized Service Center. See "Engines, Gasoline" or "Gasoline Engines" in the yellow pages of the telephone directory.

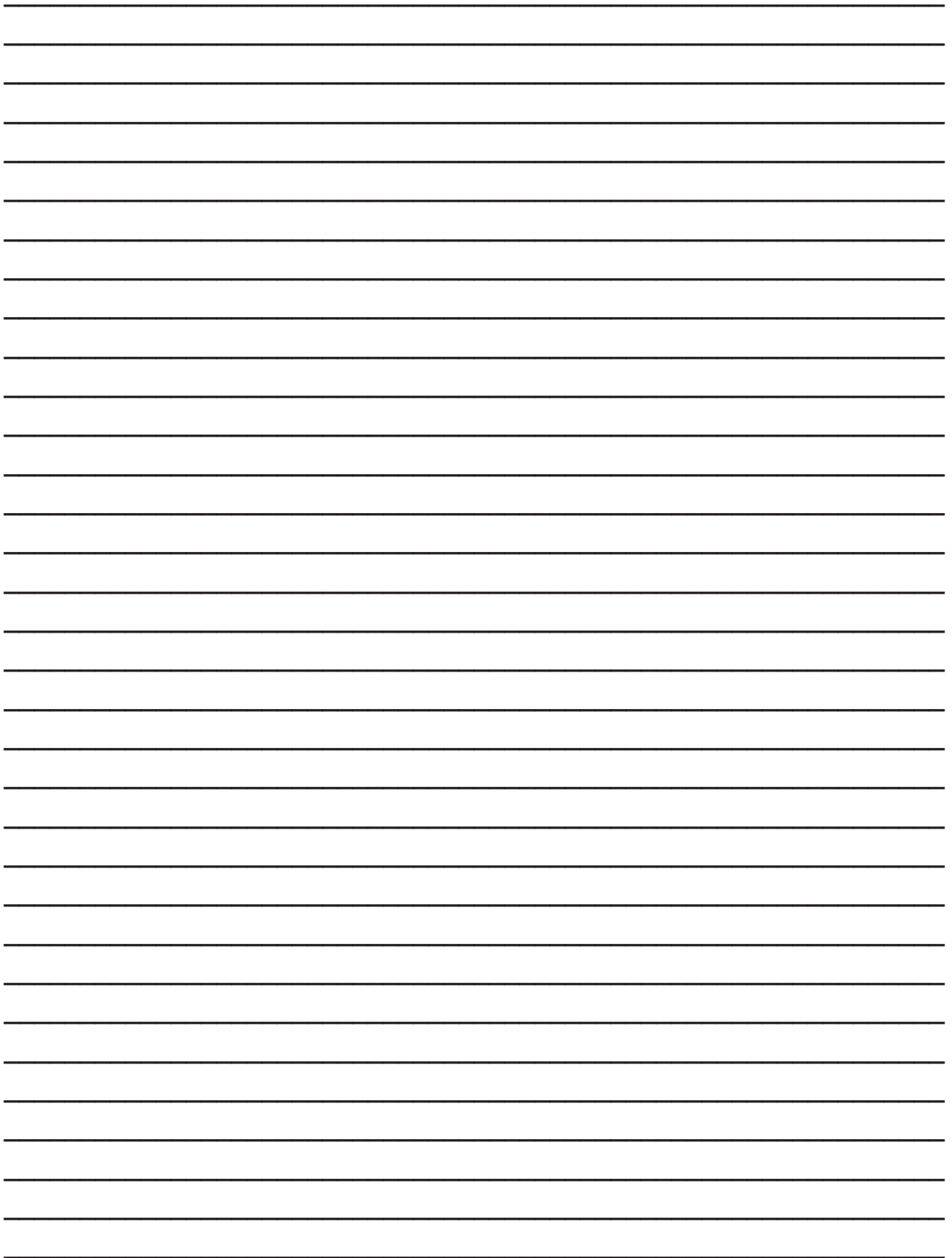

MURRAY, INC. CENTRAL PARTS DISTRIBUTORS

BILLIOU'S, INC.

1343 South Main St.
Porterville, CA. 93257
(559)784-4102 or 1-877-245-5468
FAX 1-800-266-7337
**Arizona, California, Hawaii,
Nevada**

BROWN & WISER, INC.

9991 S.W. Avery Street
Tualatin, OR. 97062
(503)692-03301-800-882-4782
FAX (503)691-2041
Alaska, Idaho (counties Ada,
Adams, Benewah, Boise, Bonner,
Boudry, Canyon, Clearwater,
Elmore, Gem, Idaho, Kooten,
Latah, Lewis, NEZ Perce, Owyee,
Payette, Ravalli, Shoshone, Valley,
Washington), **Montana** (counties
Flathead, Lake, Lincoln, Mineral,
Missoulo, Ravalli, Sanders),
Oregon, Washington

CPT CANADA POWER TECHNOLOGY LIMITED

Mississauga
161 Watline Avenue
Mississauga, Ontario L4Z-1P2
(905)890-6900 or 1-800-861-9559

Edmonton

101-10411-178 Street
Edmonton, Alberta T5S 1R5
(780)453-5791 or 1-800-861-9559

Ville St-Laurent

234 Migneron Street
Ville St-Laurent, Quebec H4T 1Y7
(514)731-35591-800-861-9559
Canada

FRANK EDWARDS CO.

3626 Parkway Blvd.
West Valley City, UT 84120
1-800-318-0201
FAX (801)736-8067
Colorado, Idaho (counties
Bannock Bearlake, Bingham,
Blaine, Booneville, Butte, Camas,
Caribou, Cassia, Custer, Franklin,
Fremont, Gooding, Jefferson,
Jerome, Lemhi, Lincoln, Madison,
Minidoka, Oneida, Power, Teton,
Twin Falls) **Montana** (all counties
except Flathead, Lake, Lincoln,
Mineral, Missoulo, Ravalli,
Sanders), **Utah, Wyoming**

GARDNER, INC.

3641 Interchange Road
Columbus, OH. 43204-1499
1-800-848-8946
FAX 1-800-626-4735
Alabama, Arkansas, (except these
counties: Hempstead, Howard,
Lafayette, Little River, Miller,
Nevada, Pike, Sevier),
**Connecticut, Delaware, District
of Columbia, Florida, Georgia,
Illinois** (South of Hwy. 80),
**Indiana, Iowa, Kansas, Kentucky,
Louisiana, Maine, Maryland,
Massachusetts, Michigan** (except
upper Peninsula), **Mississippi,
Missouri, Nebraska, New
Hampshire, New Jersey, New
York, North Carolina, Ohio,
Pennsylvania, Rhode Island,
South Carolina, Tennessee,
Vermont, Virginia, West Virginia
Puerto Rico**

GULF COAST ENGINE, INC.

4202 Russell Dr.
Corpus Christi, TX. 78408
1-800-825-6999
FAX (888)888-7036
Arkansas (counties Hempstead,
Howard, Lafayette, Little River,
Miller, Nevada, Pike, Sevier) **New
Mexico, Oklahoma, Texas,
Mexico**

WISCONSIN MAGNETO, INC.

4727 N. Teutonia Ave.
Milwaukee, WI. 53209
1-800-733-7388
FAX 1-800-733-0127
Illinois (N. of Hwy. 80), **Michigan**
(upper Peninsula), **Minnesota,
North Dakota, South Dakota,
Wisconsin**