

REPAIR PARTS SNOW THROWER -- MODEL NUMBER XT8527ES (96192002300)

AUGER HOUSING / IMPELLER ASSEMBLY

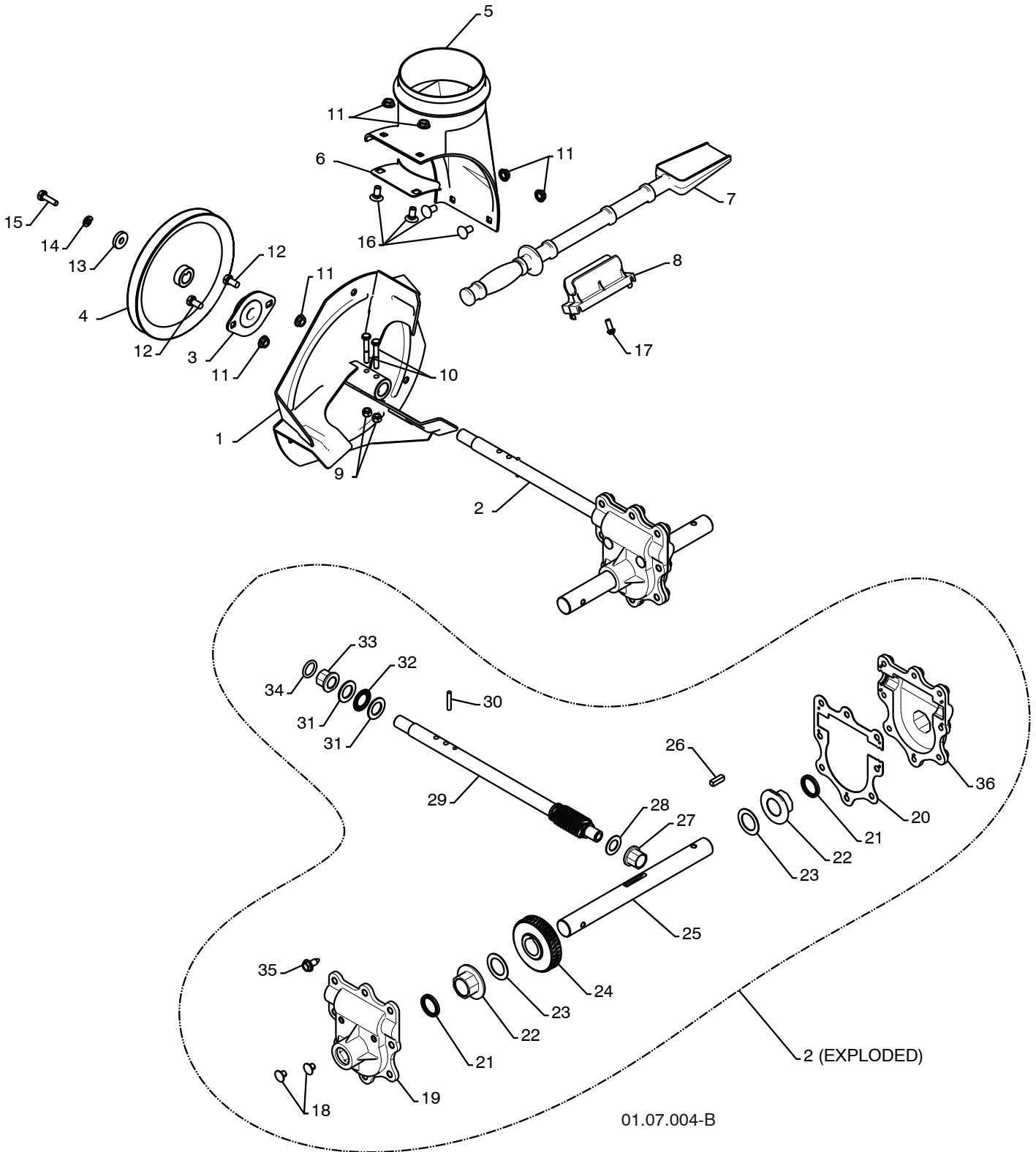

NOTE: All component dimensions given in U.S. inches. 1 inch = 25.4 mm
IMPORTANT: Use only Original Equipment Manufacturer (O.E.M.) replacement parts.
 Failure to do so could be hazardous, damage your snow thrower and void your warranty.

**REPAIR PARTS SNOW THROWER - - MODEL NUMBER XT8527ES (96192002300)
AUGER HOUSING / IMPELLER ASSEMBLY**

KEY NO.	PART NO.	DESCRIPTION
1	175321X479	IMPELLER
2	196710	GEARBOX ASSEMBLY
3	188909	BEARING
4	191079	IMPELLER PULLEY
5	175322	DISCHARGE BASE
6	178675X008	CORNER BRACKET
7	192199	CLEAN OUT TOOL
8	405400	TOOL CLIP
9	73800400	NUT 1/4-20
10	74780426	SCREW 1/4-20 X .625
11	155377	NUT 5/16-18
12	163183	SCREW 5/16-18 X .625
13	19111507	WASHER
14	10040500	LOCKWASHER 5/16
15	74940516	SCREW 5/16-18 X 1.00
16	180355	CARRIAGE BOLT
17	194189	SCREW 13-16 X .625
18	407760	PLUG
19	407761	GEARBOX COVER RH
20	407766	GASKET
21	407770	SEAL
22	407762	BEARING
23	174697	THRUST WASHER 1.00
24	407763	WORM GEAR
25	407764	AUGER SHAFT
26	189282	SQUARE KEY
27	407758	BEARING
28	174683	THRUST WASHER
29	407757	IMPELLER SHAFT
30	184205	ROLL PIN
31	174681	THRUST WASHER
32	174684	THRUST BEARING
33	407769	BEARING
34	407768	O-RING
35	407767	SCREW 5/16-18 X .750
36	407765	GEARBOX COVER LH

NOTE: All component dimensions given in U.S. inches. 1 inch = 25.4 mm
IMPORTANT: Use only Original Equipment Manufacturer (O.E.M.) replacement parts.
 Failure to do so could be hazardous, damage your snow thrower and void your warranty.

REPAIR PARTS SNOW THROWER -- MODEL NUMBER XT8527ES (96192002300)
AUGER HOUSING / IMPELLER ASSEMBLY

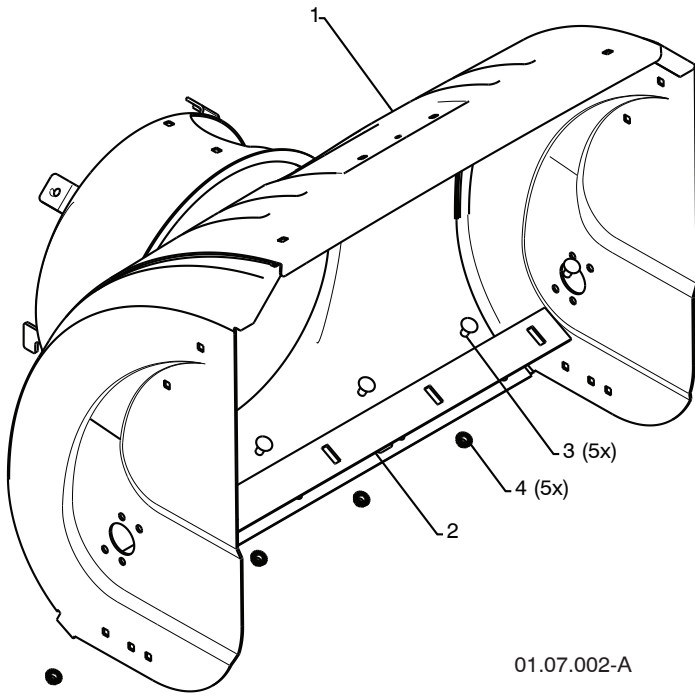

KEY NO.	PART NO.	DESCRIPTION
1	404929X505	AUGER HOUSING 27
2	404932X479	SCRAPER BAR
3	72270505	CARRIAGE BOLT 5/16-18 X .625
4	155377	NUT 5/16-18

01.07.002-A

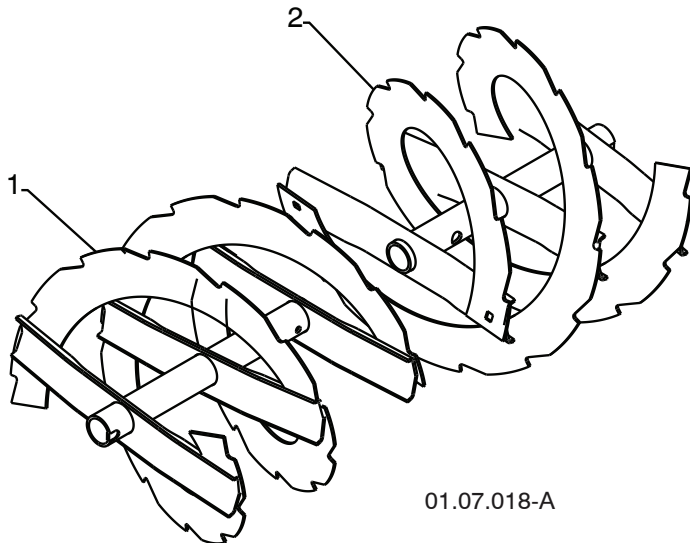

KEY NO.	PART NO.	DESCRIPTION
1	420495X479	AUGER 27 LH
2	420496X479	AUGER 27 RH

01.07.018-A

NOTE: All component dimensions given in U.S. inches. 1 inch = 25.4 mm
IMPORTANT: Use only Original Equipment Manufacturer (O.E.M.) replacement parts.
 Failure to do so could be hazardous, damage your snow thrower and void your warranty.

REPAIR PARTS SNOW THROWER - - MODEL NUMBER XT8527ES (96192002300)

AUGER HOUSING / IMPELLER ASSEMBLY

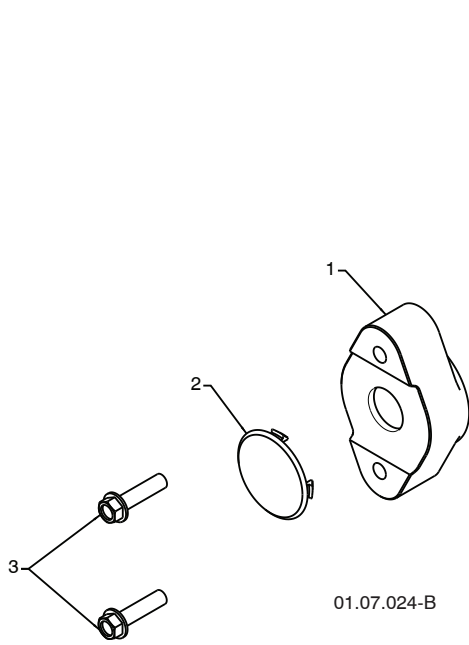

KEY NO.	PART NO.	DESCRIPTION
1	420478	AUGER BEARING
2	411939	BEARING PLUG
3	179582	SCREW 5/16-18 X 1.00

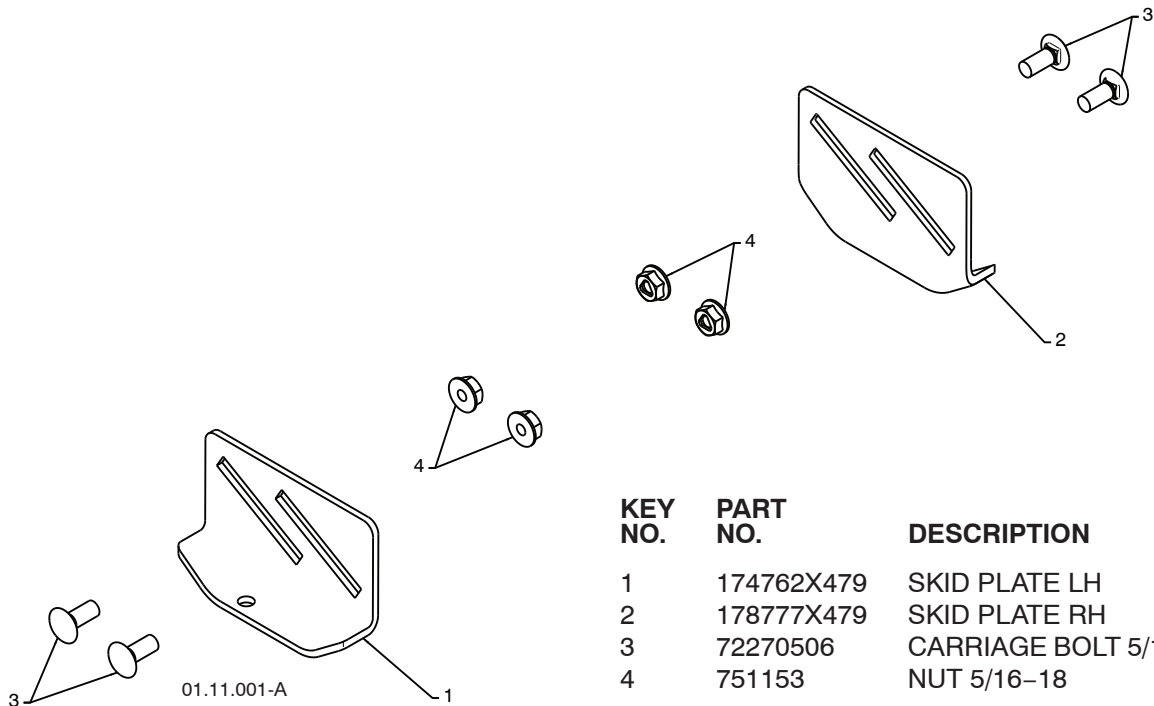

KEY NO.	PART NO.	DESCRIPTION
1	174762X479	SKID PLATE LH
2	178777X479	SKID PLATE RH
3	72270506	CARRIAGE BOLT 5/16-18 X .75
4	751153	NUT 5/16-18

NOTE: All component dimensions given in U.S. inches. 1 inch = 25.4 mm
IMPORTANT: Use only Original Equipment Manufacturer (O.E.M.) replacement parts.
 Failure to do so could be hazardous, damage your snow thrower and void your warranty.

REPAIR PARTS SNOW THROWER -- MODEL NUMBER XT8527ES (96192002300)
CONTROL PANEL / CHUTE

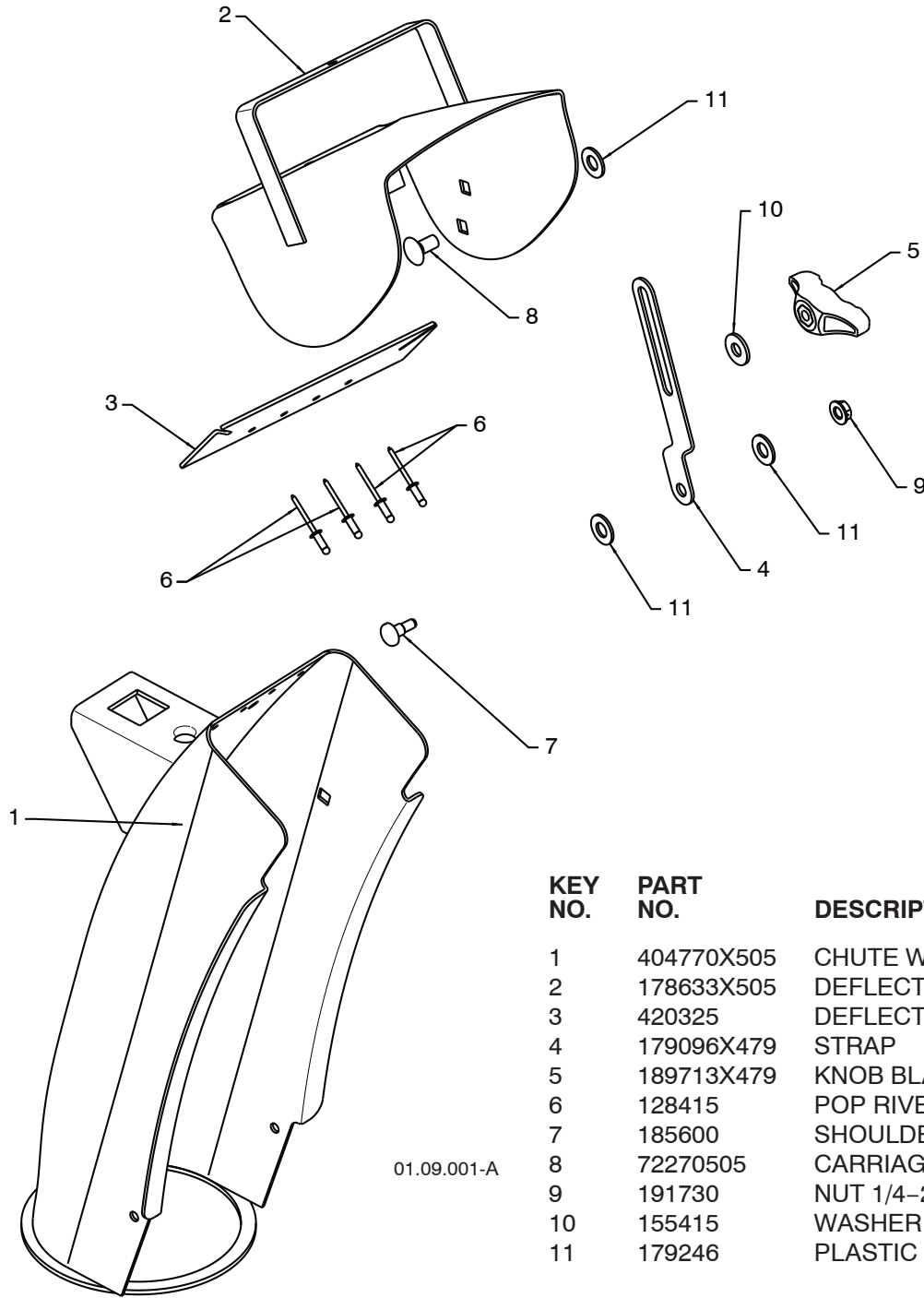

KEY NO.	PART NO.	DESCRIPTION
1	404770X505	CHUTE WELDMENT
2	178633X505	DEFLECTOR WELDMENT
3	420325	DEFLECTOR SEAL
4	179096X479	STRAP
5	189713X479	KNOB BLACK
6	128415	POP RIVET
7	185600	SHOULDER BOLT 1/4-20 X .704
8	72270505	CARRIAGE BOLT 5/16-18 X .625
9	191730	NUT 1/4-20
10	155415	WASHER
11	179246	PLASTIC WASHER

NOTE: All component dimensions given in U.S. inches. 1 inch = 25.4 mm
IMPORTANT: Use only Original Equipment Manufacturer (O.E.M.) replacement parts.
 Failure to do so could be hazardous, damage your snow thrower and void your warranty.

REPAIR PARTS SNOW THROWER -- MODEL NUMBER XT8527ES (96192002300)

CONTROL PANEL / CHUTE

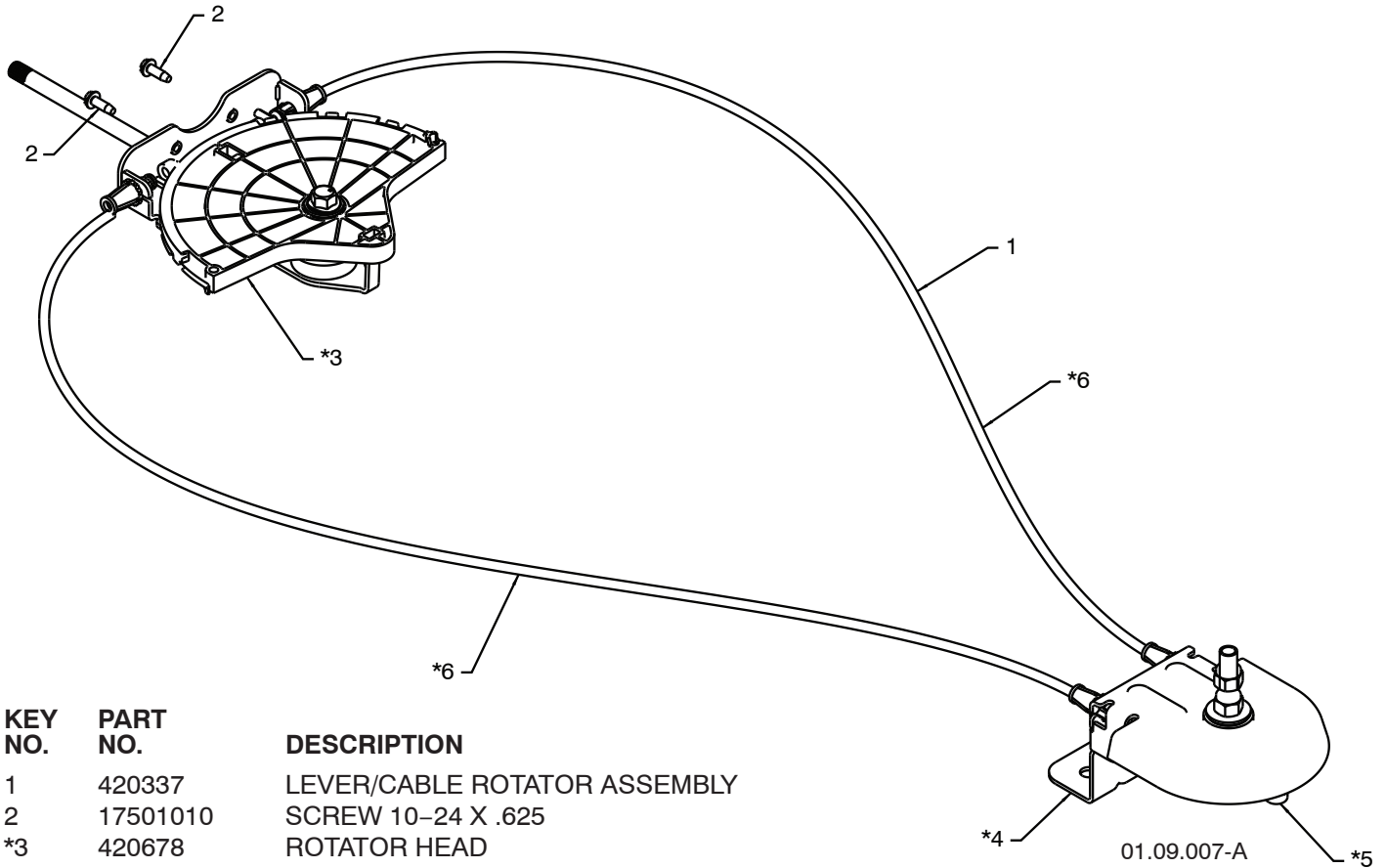

KEY NO.	PART NO.	DESCRIPTION
1	420337	LEVER/CABLE ROTATOR ASSEMBLY
2	17501010	SCREW 10-24 X .625
*3	420678	ROTATOR HEAD
*4	420677	ROTATOR PIVOT BRACKET
*5	420675	PULLEY PIVOT
*6	420674	CABLE ASSEMBLY

NOTES:

1. ITEMS INDICATED WITH AN * ARE LISTED AS REFERENCE FOR SERVICE PARTS ONLY.

NOTE: All component dimensions given in U.S. inches. 1 inch = 25.4 mm
IMPORTANT: Use only Original Equipment Manufacturer (O.E.M.) replacement parts.
 Failure to do so could be hazardous, damage your snow thrower and void your warranty.

REPAIR PARTS SNOW THROWER -- MODEL NUMBER XT8527ES (96192002300)

HANDLES

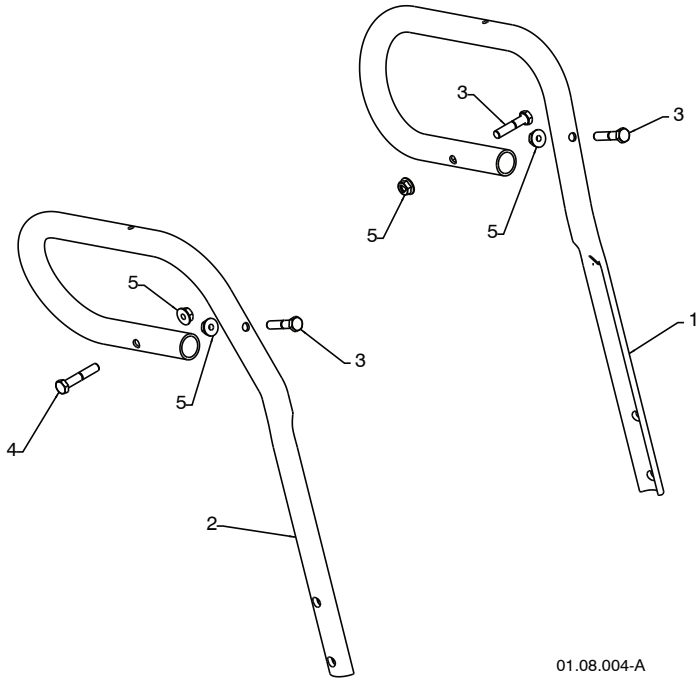

01.08.004-A

KEY NO.	PART NO.	DESCRIPTION
1	419798X479	LOOP HANDLE LH
2	419799X479	LOOP HANDLE RH
3	74780524	SCREW 5/16-18 X 1.50
4	74780528	SCREW 5/16-18 X 1.75
5	751153	NUT 5/16-18

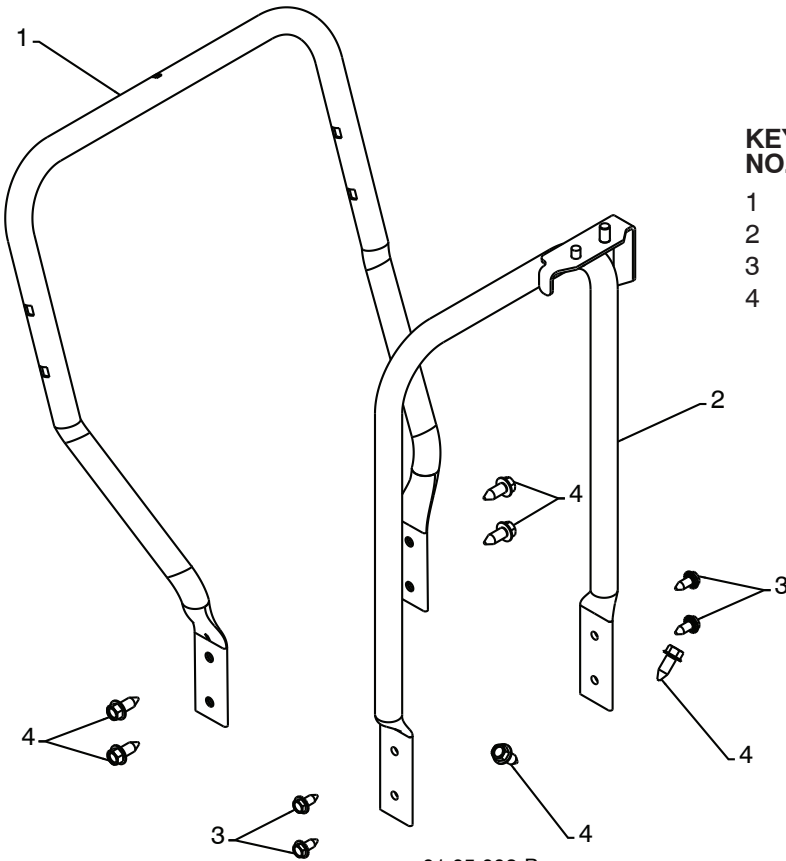

01.05.002-B

KEY NO.	PART NO.	DESCRIPTION
1	419797X479	LOWER HANDLE
2	405784X479	PIVOT SUPPORT WELDMENT
3	150078	SCREW 5/16-18 X .750
4	17000616	SCREW 3/8-16 X 1.00

NOTE: All component dimensions given in U.S. inches. 1 inch = 25.4 mm
IMPORTANT: Use only Original Equipment Manufacturer (O.E.M.) replacement parts.
 Failure to do so could be hazardous, damage your snow thrower and void your warranty.

REPAIR PARTS SNOW THROWER -- MODEL NUMBER XT8527ES (96192002300) HANDLES

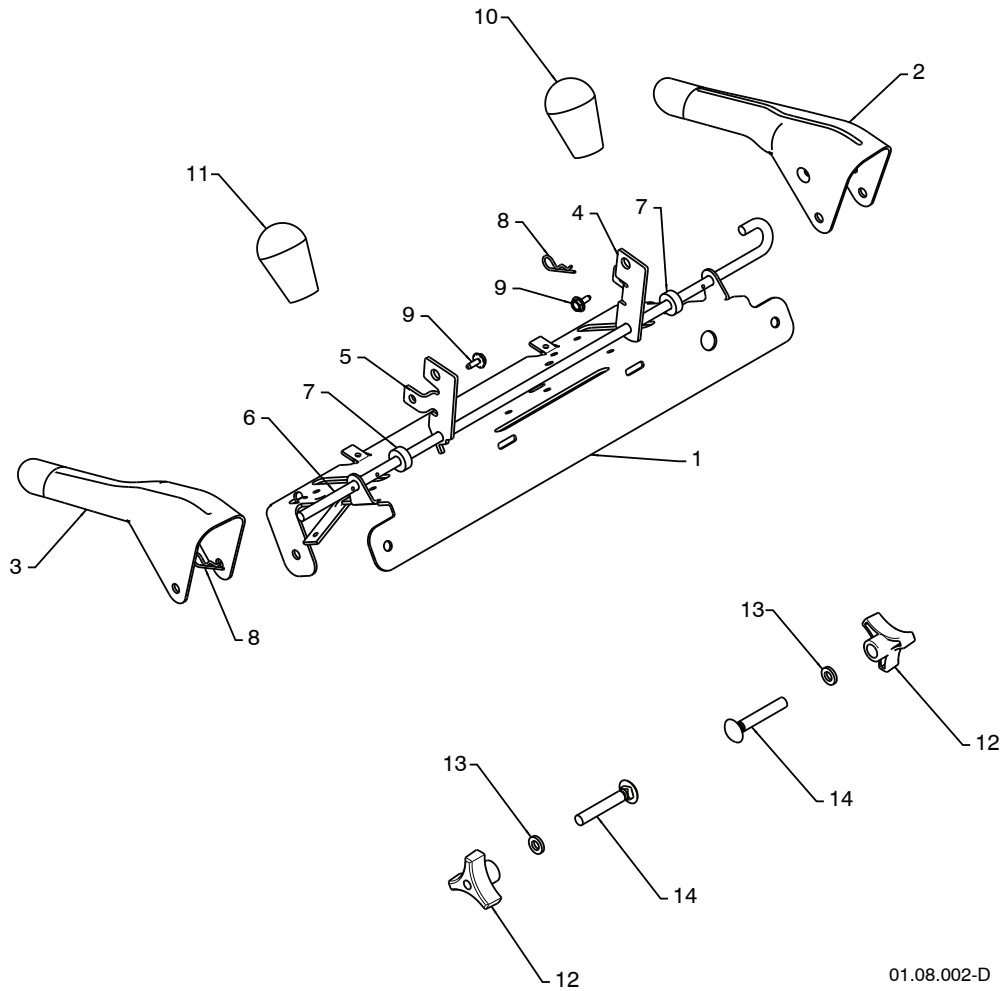

01.08.002-D

KEY NO.	PART NO.	DESCRIPTION
1	412683X479	CONTROL PANEL
2	412681X479	CONTROL LEVER LH
3	412682X479	CONTROL LEVER RH
4	412679X008	TRACTION ROD ARM
5	420889X008	IMPELLER ROD ARM
6	412677	INTERLOCK ROD
7	412680	SPACER
8	169675	RETAINER
9	17060408	SCREW 1/4-20 X .50
10	414280	KNOB BLACK
11	414281	KNOB RED
12	178899	HANDLE KNOB
13	19131316	WASHER 3/8
14	72120618	CARRIAGE BOLT 3/8-16 X 2.25

NOTE: All component dimensions given in U.S. inches. 1 inch = 25.4 mm
IMPORTANT: Use only Original Equipment Manufacturer (O.E.M.) replacement parts.
 Failure to do so could be hazardous, damage your snow thrower and void your warranty.

REPAIR PARTS SNOW THROWER -- MODEL NUMBER XT8527ES (96192002300)

HANDLES

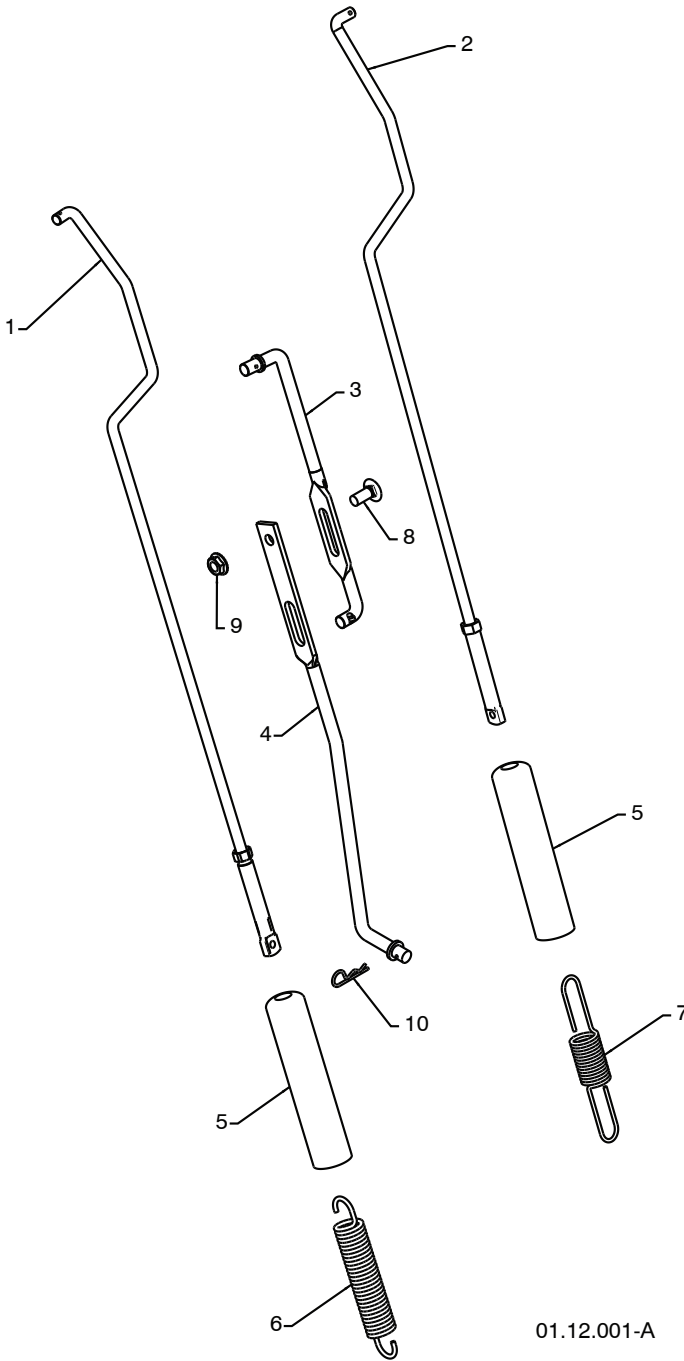

KEY NO.	PART NO.	DESCRIPTION
1	180480	IMPELLER ROD ASSEMBLY
2	405740	TRACTION ROD ASSEMBLY
3	180445	SHIFTER ROD TOP
4	187716	SHIFTER ROD BOTTOM
5	180447	SPRING SLEEVE
6	178669	IMPELLER SPRING
7	180926	TRACTION SPRING
8	72270506	CARRIAGE BOLT 5/16-18 X .75
9	155377	NUT 5/16-18
10	169675	RETAINER

01.12.001-A

NOTE: All component dimensions given in U.S. inches. 1 inch = 25.4 mm
IMPORTANT: Use only Original Equipment Manufacturer (O.E.M.) replacement parts.
 Failure to do so could be hazardous, damage your snow thrower and void your warranty.

REPAIR PARTS SNOW THROWER -- MODEL NUMBER XT8527ES (96192002300) HANDLES

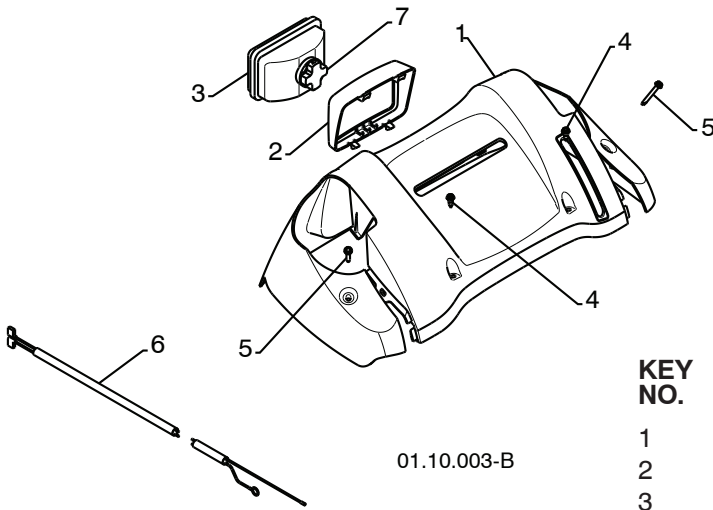

KEY NO.	PART NO.	DESCRIPTION
1	183346	CONSOLE PANEL
2	178668	HEADLIGHT BEZEL
3	180927	FLOOD HEADLIGHT
4	184471	SHOULDER SCREW 10-24 X .625
5	175262	SCREW 10-24 X 1.25
6	178770	WIRE HARNESS
7	183784	BULB

NOTE: All component dimensions given in U.S. inches. 1 inch = 25.4 mm
IMPORTANT: Use only Original Equipment Manufacturer (O.E.M.) replacement parts.
 Failure to do so could be hazardous, damage your snow thrower and void your warranty.

REPAIR PARTS SNOW THROWER -- MODEL NUMBER XT8527ES (96192002300)

DRIVE

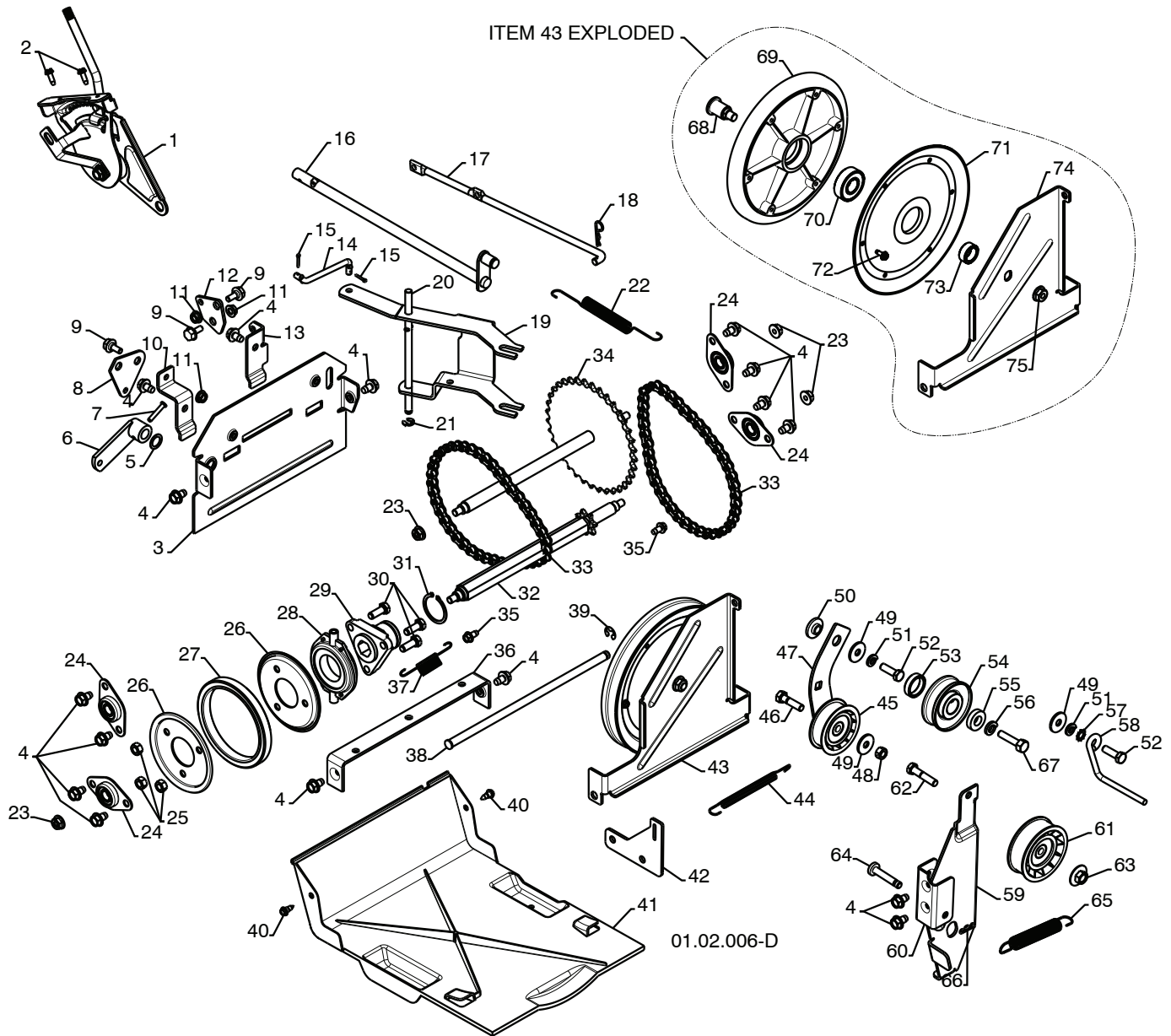

NOTE: All component dimensions given in U.S. inches. 1 inch = 25.4 mm
IMPORTANT: Use only Original Equipment Manufacturer (O.E.M.) replacement parts.
 Failure to do so could be hazardous, damage your snow thrower and void your warranty.

REPAIR PARTS SNOW THROWER - - MODEL NUMBER XT8527ES (96192002300)

DRIVE

KEY NO.	PART NO.	DESCRIPTION	KEY NO.	PART NO.	DESCRIPTION
1	198474	SPEED SELECTOR ASSEMBLY	39	12000007	E-RING .375
2	17501010	SCREW 10-24 X .625	40	184471	SHOULDER SCREW
3	402685X505	END PLATE	41	410877	BOTTOM PAN
4	17490508	SCREW 5/16-18 X .50	42	413429X479	SPRING BRACKET
5	57079	WASHER	43	420900	DRIVE PLATE ASSEMBLY
6	405485	CONTROL ARM	44	414557	IDLER SPRING
7	198580	CLEVIS PIN	45	180522	IDLER PULLEY
8	403097X004	SHIFTER PLATE	46	74780520	SCREW 5/16-18 X 1.25
9	402881	SHOULDER BOLT	47	187786	IDLER ARM
10	403096X004	SHIFTER BRACKET	48	73930500	NUT 5/16-18
11	191730	NUT 1/4-20	49	59289	WASHER
12	402856X004	CLUTCH PLATE	50	175331	PIVOT BUSHING
13	416717X004	CLUTCH BRACKET	51	10040500	LOCKWASHER 5/16
14	187101	SHIFTER LINK	52	74610516	SCREW 5/16-18 X 1.00
15	700279	RETAINER	53	409475	SPACER
16	406109	CONTROL SHAFT	54	180478	TRACTION PULLEY
17	402568	CLUTCH ROD	55	400026	WASHER 3/8
18	169675	RETAINER	56	850263	LOCKWASHER 3/8
19	401732	SHIFTER YOKE	57	11050500	LOCKWASHER
20	402310	PIVOT ROD	58	155452	BELT GUIDE
21	402882	RETAINER	59	419925X479	IDLER ARM
22	402878	RETURN SPRING	60	175324X479	IDLER BRACKET
23	751153	NUT 5/16-18	61	180523	IDLER PULLEY
24	408981	BEARING	62	74780524	SCREW 5/16-18 X 1.50
25	73930500	NUT 5/16-18	63	166785	NUT 5/16-18
26	198176X479	RUBBER WHEEL PLATE	64	175330	PIN IDLER PIVOT
27	179831	RUBBER RING	65	178828	IDLER SPRING
28	175344	BEARING	66	85179	RETAINER
29	178613	WHEEL HUB	67	851084	SCREW 3/8-24 X 1.375
30	74760514	SCREW 5/16-18-.875	68	402504	PULLEY SHAFT
31	12000012	RETAINER RING	69	401820	DRIVE PLATE
32	402187	SPROCKET SHAFT	70	198791	BEARING
33	401619	CHAIN	71	402393	PULLEY HALF
34	417234	SPROCKET WELDMENT	72	17541008	SCREW 10-24 X .50
35	17490408	SCREW 1/4-20 X .50	73	402511	SPACER BEARING
36	401984X479	SHIFTER BRACKET	74	402394	SWING PLATE
37	180135	SPRING	75	132010	NUT 3/8-16
38	402652	PLATE PIVOT ROD			

NOTE: All component dimensions given in U.S. inches. 1 inch = 25.4 mm
IMPORTANT: Use only Original Equipment Manufacturer (O.E.M.) replacement parts.
 Failure to do so could be hazardous, damage your snow thrower and void your warranty.

REPAIR PARTS SNOW THROWER -- MODEL NUMBER XT8527ES (96192002300) DRIVE

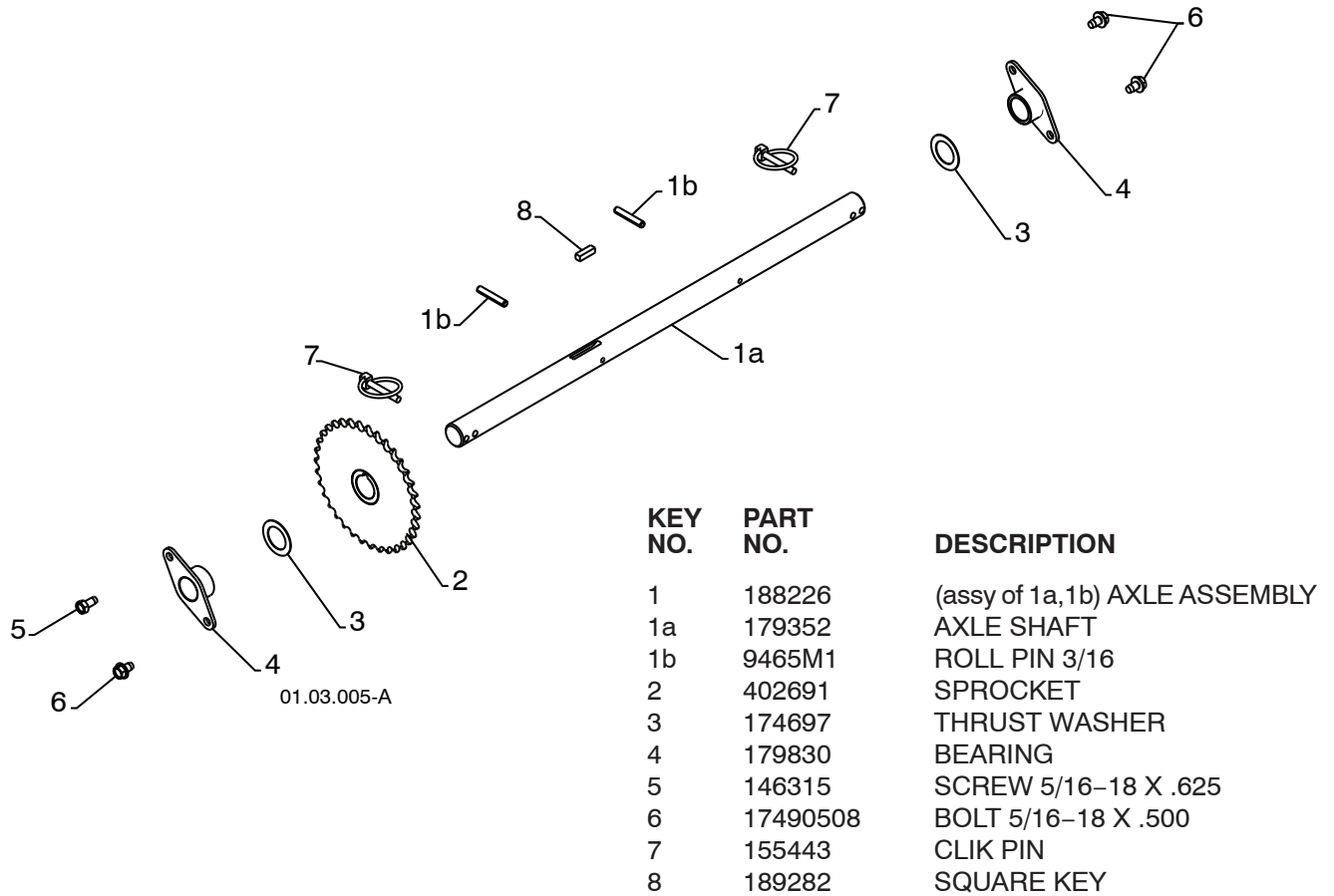

NOTE: All component dimensions given in U.S. inches. 1 inch = 25.4 mm
IMPORTANT: Use only Original Equipment Manufacturer (O.E.M.) replacement parts.
 Failure to do so could be hazardous, damage your snow thrower and void your warranty.

REPAIR PARTS SNOW THROWER -- MODEL NUMBER XT8527ES (96192002300)
CHASSIS / ENGINE / PULLEYS

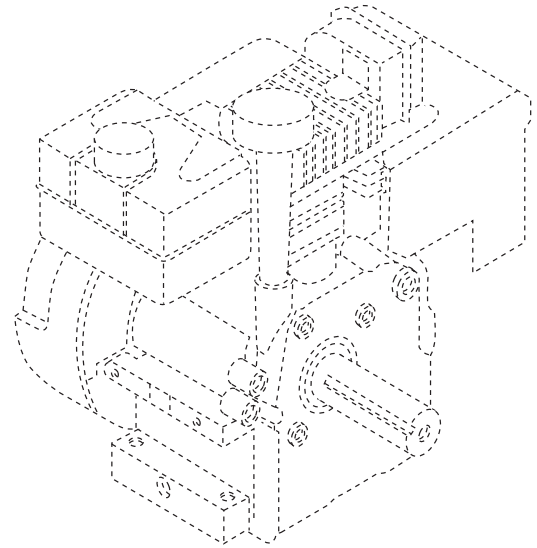
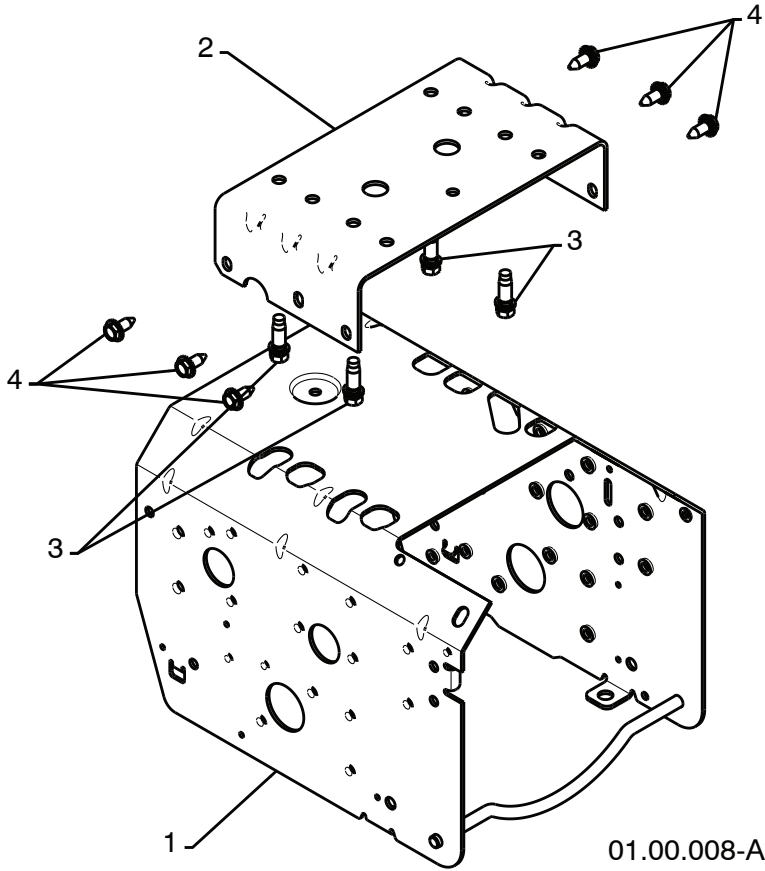

01.00.008-A

KEY NO.	PART NO.	DESCRIPTION
--	-----	ENGINE TECUMSEH MODEL LH318SA-156551H
1	409346X505	FRAME
2	417014X505	ENGINE MOUNT PLATE
3	150406	BOLT 3/8-16
4	150078	SCREW 5/16-18 X .750

NOTE: All component dimensions given in U.S. inches. 1 inch = 25.4 mm
IMPORTANT: Use only Original Equipment Manufacturer (O.E.M.) replacement parts.
 Failure to do so could be hazardous, damage your snow thrower and void your warranty.

REPAIR PARTS SNOW THROWER -- MODEL NUMBER XT8527ES (96192002300)
CHASSIS / ENGINE / PULLEYS

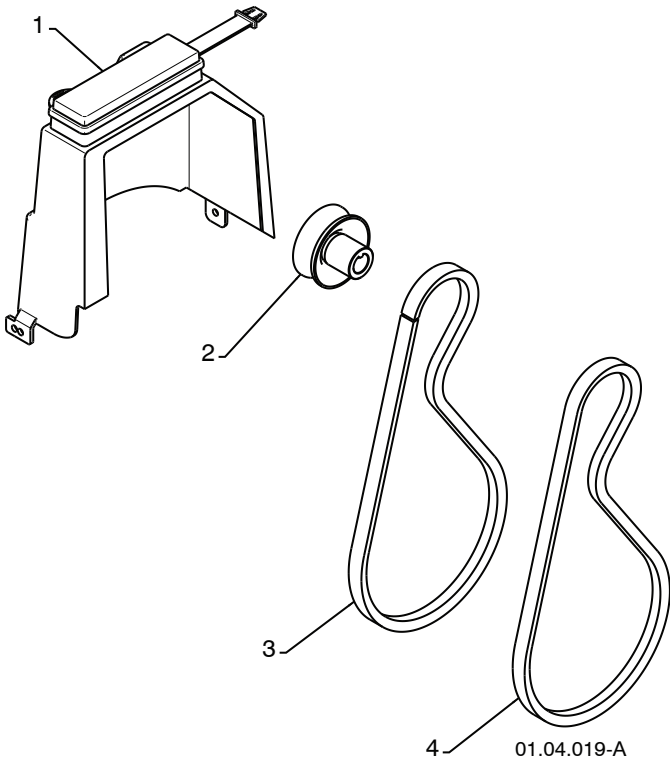

KEY NO.	PART NO.	DESCRIPTION
1	192213	BELT COVER
2	179157	IMPELLER PULLEY
3	419744	TRACTION BELT
4	408007	IMPELLER BELT

NOTE: All component dimensions given in U.S. inches. 1 inch = 25.4 mm
IMPORTANT: Use only Original Equipment Manufacturer (O.E.M.) replacement parts.
 Failure to do so could be hazardous, damage your snow thrower and void your warranty.

REPAIR PARTS SNOW THROWER -- MODEL NUMBER XT8527ES (96192002300)
WHEELS

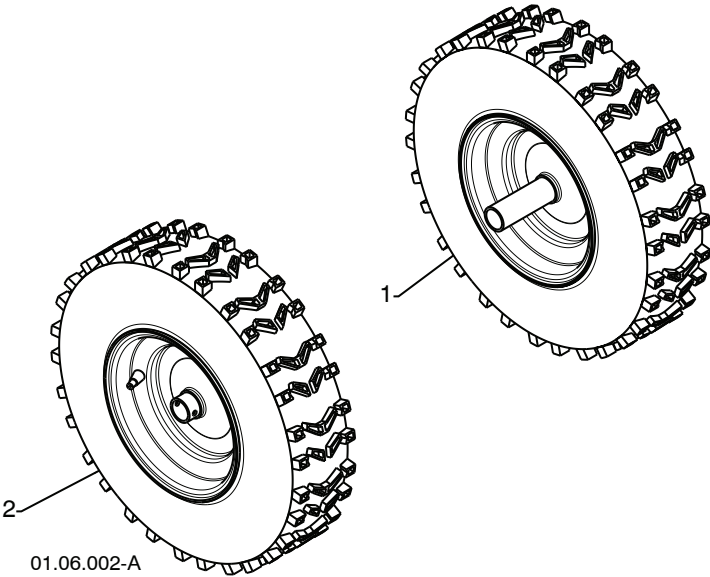

KEY NO.	PART NO.	DESCRIPTION
1	187833X428	WHEEL ASSEMBLY LH
2	187865X428	WHEEL ASSEMBLY RH

NOTE: All component dimensions given in U.S. inches. 1 inch = 25.4 mm
IMPORTANT: Use only Original Equipment Manufacturer (O.E.M.) replacement parts.
 Failure to do so could be hazardous, damage your snow thrower and void your warranty.

REPAIR PARTS SNOW THROWER -- MODEL NUMBER XT8527ES (96192002300)

BAG OF PARTS

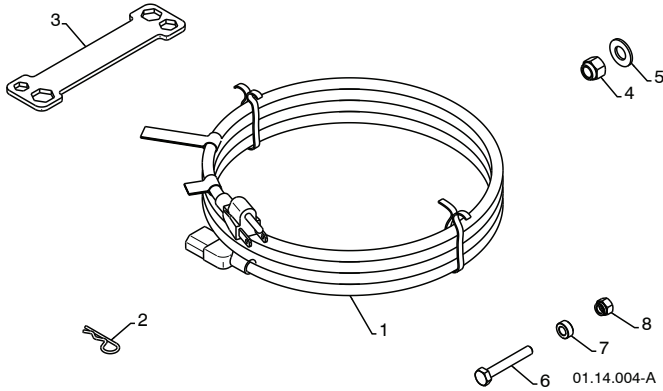

KEY NO.	PART NO.	DESCRIPTION
1	198563	POWER CORD
2	169675	RETAINER PIN
3	180684	WRENCH
4	73800600	LOCKNUT 3/8-16
5	19131316	WASHER 3/8
6	198636	SHEAR BOLT 1/4-20 X 1-3/4
7	198638	SPACER
8	73800400	LOCKNUT 1/4-20

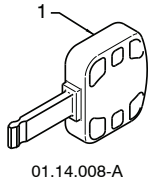

KEY NO.	PART NO.	DESCRIPTION
1	35062	SAFETY IGNITION KEY

NOTE: All component dimensions given in U.S. inches. 1 inch = 25.4 mm
IMPORTANT: Use only Original Equipment Manufacturer (O.E.M.) replacement parts.
 Failure to do so could be hazardous, damage your snow thrower and void your warranty.

REPAIR PARTS SNOW THROWER -- MODEL NUMBER XT8527ES (96192002300) DECALS

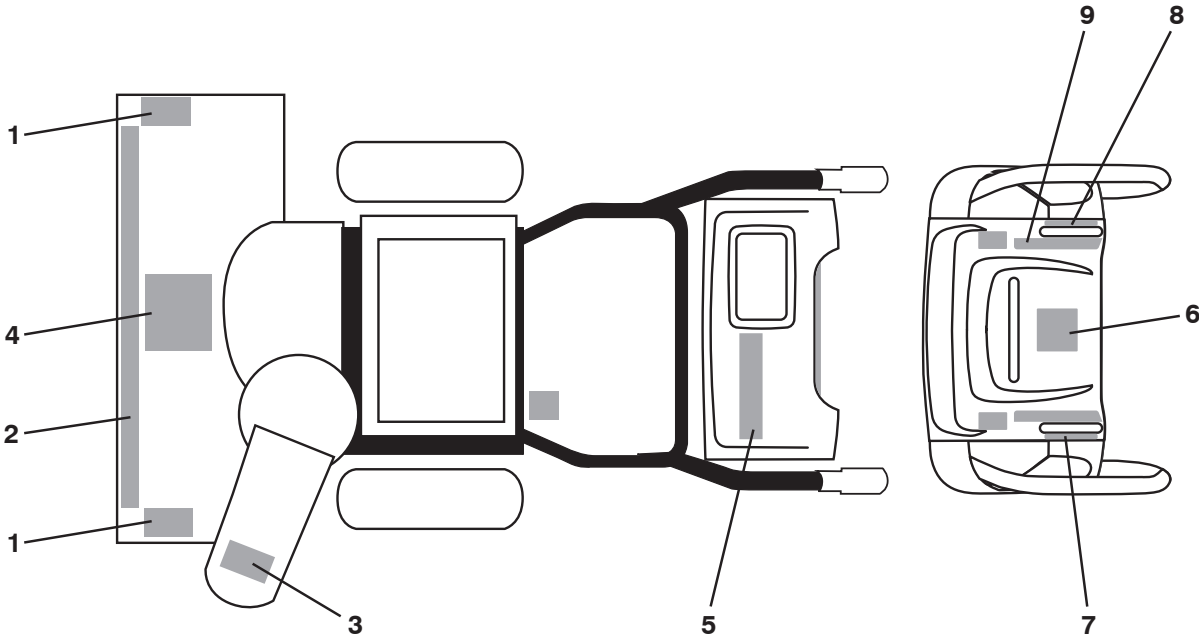

KEY NO.	PART NO.	DESCRIPTION
1	181037	DECAL, DANGER
2	422147	DECAL, POULAN PRO XT, 8.5 HP / 27"
3	181035	DECAL, DANGER, DEFLECTOR
4	181042	DECAL, DANGER
5	422146	DECAL, POULAN PRO XT, 8.5 HP / 27"
6	181033	DECAL, INSTRUCTION
7	415391	DECAL, LH TRACT/CLUTCH LEV LH
8	415390	DECAL, RH AUGER LEVER RT
9	415475	DECAL, SPEED CONTROL
--	422071	OWNER'S MANUAL, ENGLISH
--	422072	OWNER'S MANUAL, FRENCH

NOTE: All component dimensions given in U.S. inches. 1 inch = 25.4 mm
IMPORTANT: Use only Original Equipment Manufacturer (O.E.M.) replacement parts.
 Failure to do so could be hazardous, damage your snow thrower and void your warranty.