

TRACTOR - MODEL NO. YTH23V48 (96043011003), PRODUCT NO. 960 43 01-10 SCHEMATIC

SCH12

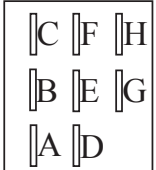

PTO SWITCH (MATING SIDE)

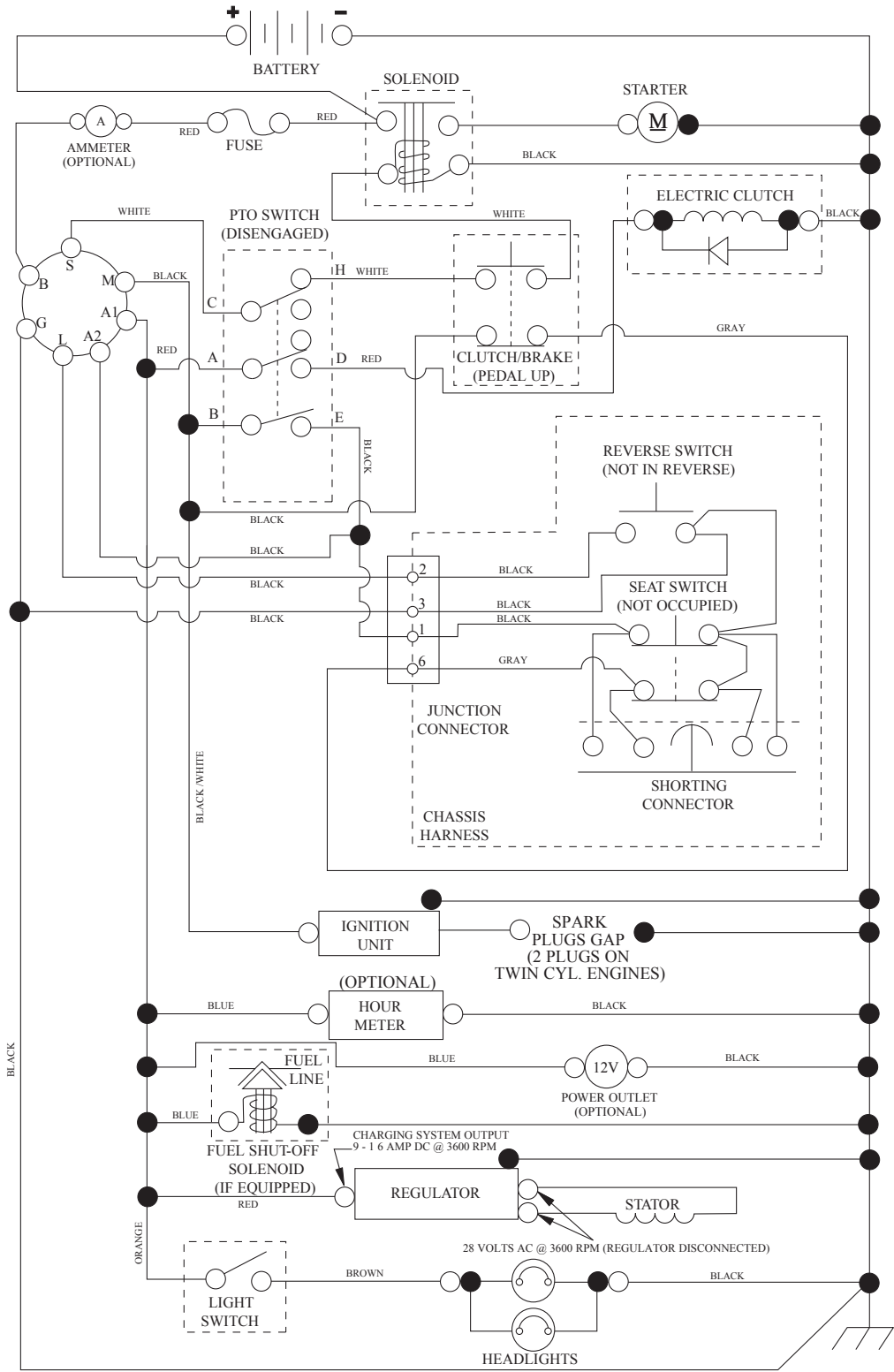
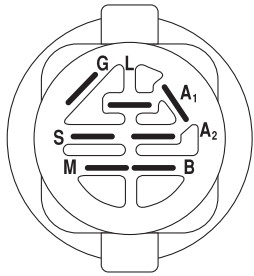

POSITION	CIRCUIT "MAKE"
OFF	M+G+A1
RUN/OVERRIDE	B+A1
RUN	B+A1 L+A2
START	B+S+A1

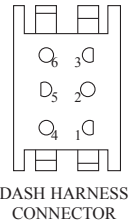

WIRING INSULATED CLIPS
NOTE: IF WIRING INSULATED CLIPS WERE REMOVED FOR SERVICING OF UNIT, THEY SHOULD BE RE-INSTALLED TO PROPERLY SECURE YOUR WIRING.

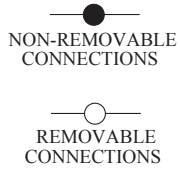

**TRACTOR - MODEL NO. YTH23V48 (96043011003), PRODUCT NO. 960 43 01-10
ELECTRICAL**

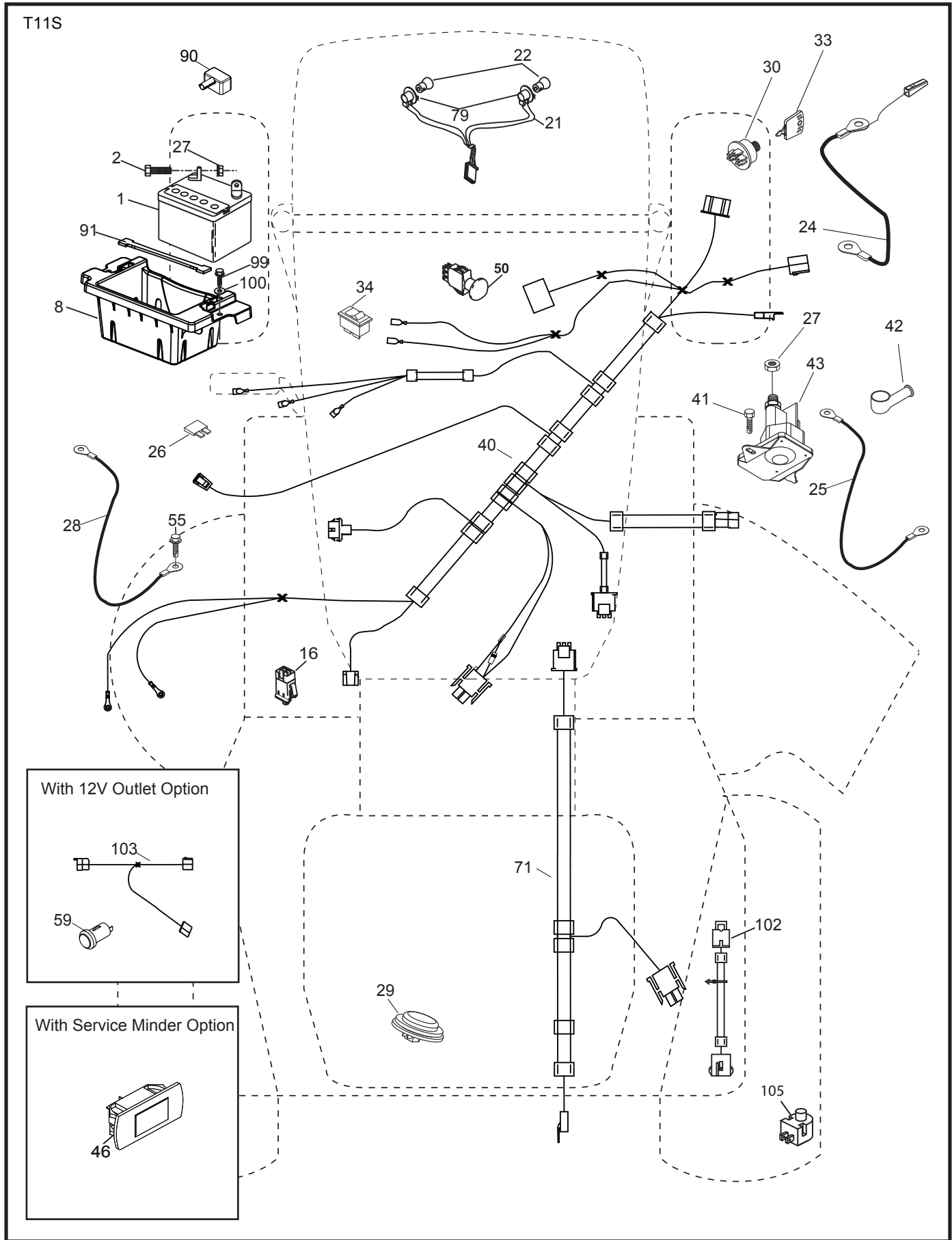

**TRACTOR - MODEL NO. YTH23V48 (96043011003), PRODUCT NO. 960 43 01-10
ELECTRICAL**

KEY NO.	PART NO.	DESCRIPTION
1	532 16 34-65	Battery
2	874 76 04-12	Bolt Hex Hd 1/4-20 unc x 3/4
8	532 18 64-91	Battery Box
16	532 17 61-38	Switch Bagger Present
21	532 40 02-52	Harness Socket Light
22	532 00 41-52	Bulb, Light #1156
24	532 40 02-53	Cable Battery
25	532 41 28-95	Cable Starter
26	532 17 51-58	Fuse
27	873 51 04-00	Nut Keps Hex 1/4-20 unc
28	532 14 54-91	Cable Ground 21" Blk 6 Ga.
29	532 40 15-45	Switch Seat
30	532 19 33-50	Switch Ign
33	532 41 19-33	Key/Chain
34	532 11 07-12	Switch Light/Reset
40	532 40 11-04	Harness Ign. Dash
41	817 72 04-08	Screw Thd Cut 1/4-20 x 1/2
42	532 13 15-63	Cover Terminal Red
43	532 19 25-07	Solenoid
46	532 40 17-63	Gauge Hourmeter
50	532 17 46-51	Switch PTO
55	817 06 05-12	Screw Thdrol 5/16-18 x 3/4
71	532 19 42-76	Harness Ign
79	532 17 52-42	Socket Asm. Bulb Twistlock
90	532 43 53-95	Cover Terminal Battery
91	532 19 02-70	Strap Battery
99	817 67 04-12	Screw Hexwsh Thdrol 1/4-20 x 3/4
100	819 09 14-16	Washer 9/32 x 7/8 x 16 Ga.
102	532 40 44-54	Harness Pigtail
105	532 40 75-68	Switch Reverse TT Pedal Control

NOTE: All component dimensions given in U.S. inches
1 inch = 25.4 mm

**TRACTOR - MODEL NO. YTH23V48 (96043011003), PRODUCT NO. 960 43 01-10
CHASSIS**

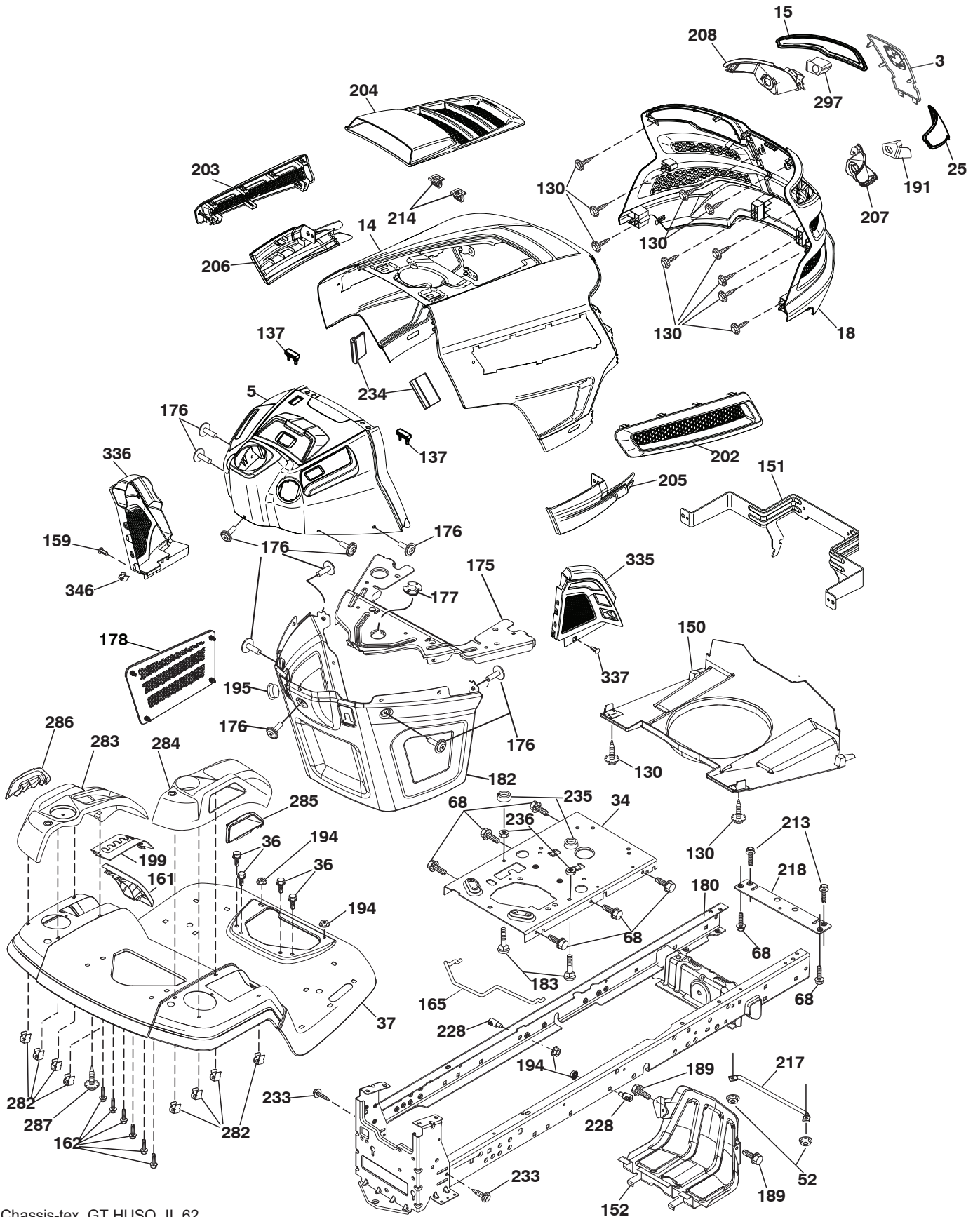

Chassis-tex_GT HUSQ_II_62

**TRACTOR - MODEL NO. YTH23V48 (96043011003), PRODUCT NO. 960 43 01-10
CHASSIS**

KEY NO.	PART NO.	DESCRIPTION	KEY NO.	PART NO.	DESCRIPTION
3	532 43 97-52	Logo	202	532 43 97-28	Vent Side Hood RH
5	532 43 74-71	Dash	203	532 43 97-27	Vent Side Hood LH
14	532 44 11-77	Hood	204	532 43 57-14	Vent Top Hood
15	532 43 97-33	Lens LH	205	532 43 97-30	Skirt Hood Side RH
18	532 43 77-62	Grille Asm.	206	532 43 97-29	Skirt Hood Side LH
25	532 44 33-85	Lens RH	207	532 43 97-34	Bezel RH
34	532 19 61-25	Plate Engine	208	532 43 97-35	Bezel LH
36	817 06 05-12	Screw 5/16-18 x 3/4	213	874 76 05-12	Bolt 5/16-18 unc x 3/4
37	532 44 11-78	Fender	214	532 19 91-45	Clip Retainer Tinner
52	873 68 05-00	Nut Lock 5/16-18	217	532 40 91-67	Rod Pivot
68	817 49 05-08	Screw 5/16-18 x 1/2	218	532 19 63-95	X-Piece Hood Stop
130	532 41 63-58	Screw #10 x 0.750 BOS Thread	228	532 19 51-61	Stud Fastner
137	532 40 75-90	Bumper Dash	233	532 19 65-39	Bolt, Shoulder
150	532 43 97-74	Air Duct	234	532 40 47-42	Bumper Hood
151	532 43 66-70	Pivot Bracket	235	532 40 61-29	Spacer Fender
152	532 43 60-86	Shield Browning	236	873 93 05-00	Nut Lock 5/16-18 unc
159	817 00 06-12	Screw 3/8-16 x 3/4	282	532 41 41-10	Clip Retainer Console
161	532 43 97-81	Window Fuel	283	532 43 98-61	Console Asm. Decklift
162	532 14 24-32	Screw	284	532 43 98-23	Console Asm.
165	532 19 68-26	Support Tank Rear	285	532 41 63-15	Console Insert RH
175	532 19 63-04	Crossmember	286	532 41 63-17	Console Insert LH
176	532 40 07-76	Screw 10-24 x 5/8	287	817 60 04-06	Screw Hex Washhead 1/4-20 x 3/8
177	532 19 52-27	Bushing Steering	297	532 43 74-56	Insert Reflective LH
178	532 19 97-82	Cargo Asm. Net	335	532 43 98-47	Cover Lower Dash RH
180	532 19 54-57	Chassis	336	532 44 53-09	Cover Lower Dash LH
182	532 40 68-59	Dash Lower	337	532 43 81-37	Clip xmas tree
183	874 52 05-20	Bolt 5/16-18 x 1-1/4 Full. Thd.	346	532 12 64-71	Clip Insulator 13/32
189	817 00 05-12	Screw 5/16-18 x 3/4			
191	532 43 74-55	Insert Reflective RH			
194	873 90 05-00	Nut Lock Hex Flange 5/16-18			
195	532 40 41-37	Plug Hole Dash Lower			
199	532 41 34-85	Plate Deck Lift			

NOTE: All component dimensions given in U.S. inches
1 inch = 25.4 mm

**TRACTOR - MODEL NO. YTH23V48 (96043011003), PRODUCT NO. 960 43 01-10
DRIVE**

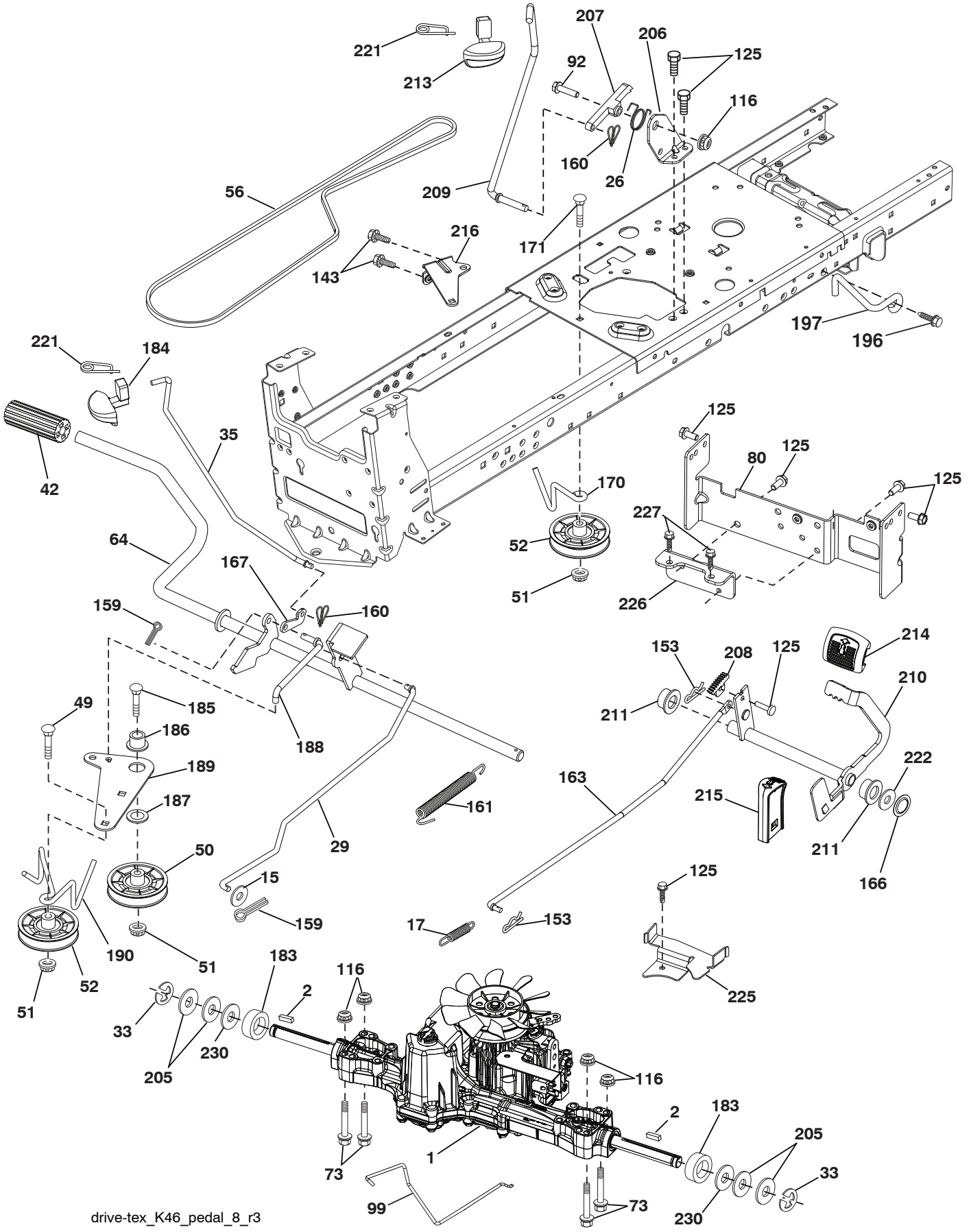

drive-tex_K46_pedal_8_r3

TRACTOR - MODEL NO. YTH23V48 (96043011003), PRODUCT NO. 960 43 01-10 DRIVE

KEY NO.	PART NO.	DESCRIPTION	KEY NO.	PART NO.	DESCRIPTION
1	---	Transaxle, TUFFTORQ K46 BT (426120)(Order parts from transaxle manufacturer	171	872 11 06-16	Bolt RDHD SQNK 3/8-16 unc x 2
2	532 12 35-83	Key	183	532 13 70-57	Spacer Split
15	819 13 13-16	Washer 13/32 x 13/16 x 16 Ga.	184	532 44 14-55	Handle Parking Brake
17	532 41 36-78	Spring, Brake	185	872 11 06-22	Bolt Rdhd Sqnk 3/8-16 x 2-3/4 Gr. 5
26	532 19 96-79	Spring Return Cruise	186	532 19 43-21	Spacer Retainer
29	532 40 38-06	Rod, Brake	187	819 13 32-10	Washer
33	812 00 00-01	Ring E	188	532 19 43-23	Link Clutch Ground Drive
35	532 43 54-86	Rod, Brake, Park	189	532 19 43-17	Bellcrank Ground Drive
42	532 12 48-72	Cover, Foot Pedal	190	532 19 43-18	Keeper Bellcrank Ground Drive
49	872 11 06-14	Bolt	196	817 00 06-16	Screw 3/8-16 x 1
50	532 19 43-27	Pulley Idler Flat	197	532 19 58-04	Bracket Clutch Anti-Rotation
51	873 90 06-00	Lock Nut 3/8-16	205	532 12 17-48	Washer
52	532 19 43-26	Idler V-Groove 910" Offset	206	532 19 78-67	Bracket Mount Latch Cruise
56	532 13 09-69	V-Belt, Drive	207	532 19 78-68	Latch Control Cruise
64	532 19 78-65	Shaft Asm. Pedal Brake Control	208	532 19 78-69	Gear Sector Control Cruise
73	874 49 05-40	Bolt Hex Flghd 5/16-18 Gr. 5	209	532 19 95-92	Rod Control Cruise
80	532 44 06-19	Strap Torque	210	532 40 09-80	Rocker Asm. Pedal Control
92	874 76 05-20	Bolt Fin Hex 5/16-18 unc x 1.25	211	532 12 01-83	Bearing Nylon
99	532 41 57-42	Rod Asm. Bypass	213	532 40 31-19	Knob Control Cruise
116	873 90 05-00	Nut Lock Hex Flange 5/16-18	214	532 42 12-63	Pedal Forward Pad
125	817 00 05-12	Screw 5/16-18 x 3/4	215	532 40 17-23	Pedal Reverse
143	817 49 05-08	Screw 5/16-18 x 1/2	216	532 19 61-31	Bracket Pulley Idler
153	532 12 47-88	Retainer Spring	221	532 40 31-87	Retainer Spring Clip Handle
159	876 02 04-12	Pin Cotter 1/8 x 3/4	222	879 21 20-10	Washer 21/32 x 1-1/4 x 10 Ga.
160	532 16 94-84	Retainer Clip	227	817 49 05-12	Screw Thd. 5/16-18 x 3/4
161	532 10 57-09	Spring, Return, Clutch	225	532 40 33-19	Keeper Belt Trans.
163	532 40 10-34	Rod Pedal Control	226	532 40 15-64	Bracket Mount Torque
166	532 42 91-64	Nut Push	230	532 18 89-67	Washer Hardened
167	532 40 52-57	Latch Brake Parking			
170	532 19 43-22	Keeper Belt Centerspan			

NOTE: All component dimensions given in U.S. inches
1 inch = 25.4 mm

**TRACTOR - MODEL NO. YTH23V48 (96043011003), PRODUCT NO. 960 43 01-10
ENGINE**

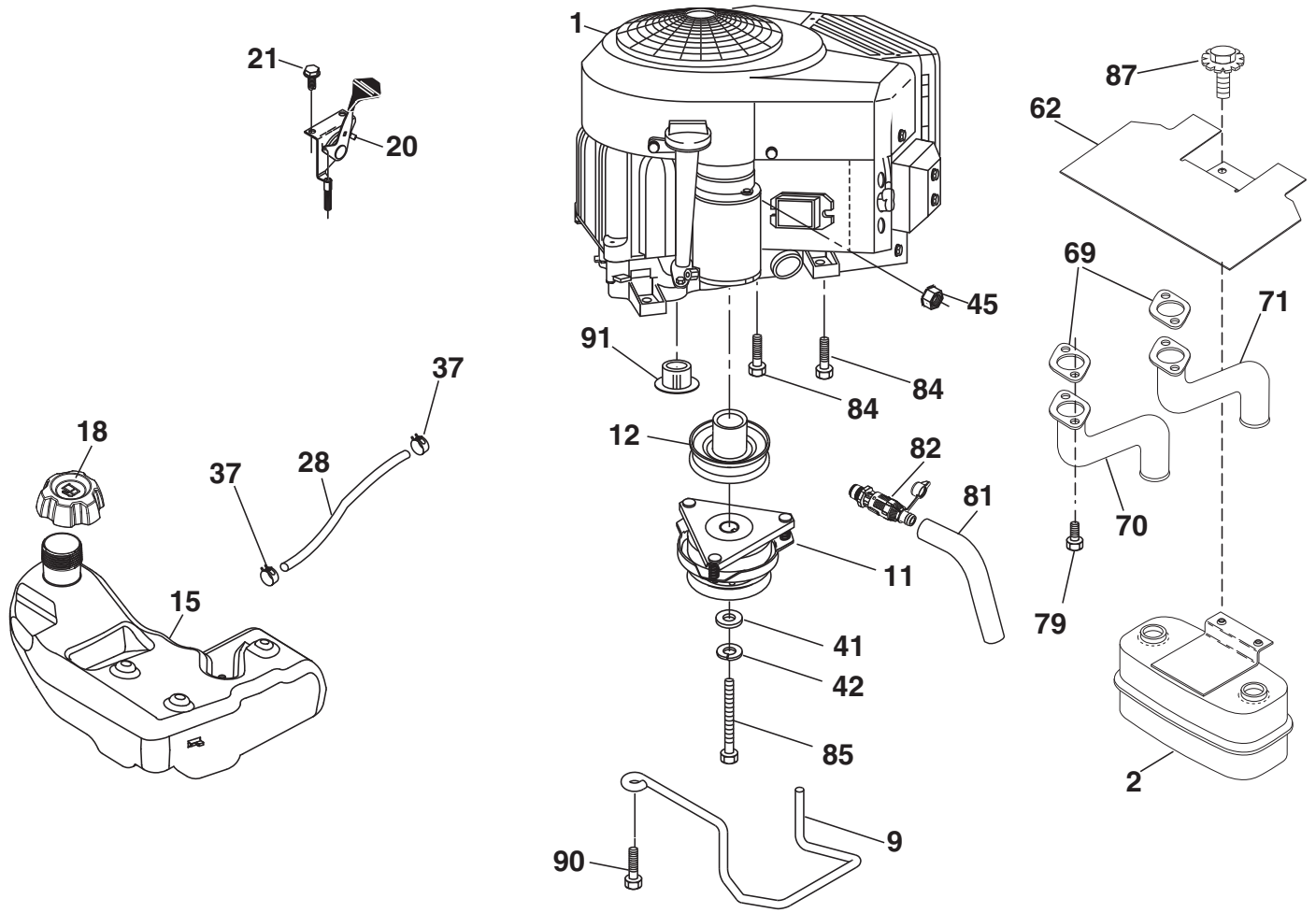

SPARK ARRESTER KIT

engine-tex_bs-2cyl_47_r1

TRACTOR - MODEL NO. YTH23V48 (96043011003), PRODUCT NO. 960 43 01-10 ENGINE

KEY NO.	PART NO.	DESCRIPTION
1	---	Engine Briggs Model No. 445577-2187-G1(438201) (Order parts from engine manufacturer)
2	532 14 97-23	Muffler
9	532 19 43-20	Keeper Belt Engine
11	532 40 00-08	Clutch Electric
12	532 40 50-97	Pulley Engine
15	532 43 80-80	Tank Fuel
18	532 43 92-08	Cap Asm
20	532 42 35-02	Control Throttle
21	532 41 63-58	Screw #10 x 0.750 BOS Thread
28	532 40 11-35	Fuel Line
29	532 13 71-80	Spark Arrester Kit
37	532 12 34-87	Clamp Hose
41	532 12 61-97	Washer 1-1/2 OD x 15/32 ID x .250
42	810 04 07-00	Washer Lock 7/16
45	873 51 04-00	Nut Keps Hex 1/4-20 unc
62	532 43 40-17	Shield Heat Muffler
69	532 16 53-91	Gasket
70	532 15 99-55	Tube Exhaust LH
71	532 16 05-89	Tube Exhaust RH
79	532 18 39-06	Screw Socket Head 5/16-18 x 1
81	532 14 84-56	Tube Drain Oil Easy
82	532 42 82-87	Valve Oil Drain
84	817 06 06-20	Screw 3/8-16 x 1-1/4
85	532 17 39-37	Bolt Hex 7/16-20 x 4 Gr. 5
87	532 17 18-77	Bolt 5/16-18 unc x 1 w/Sems
90	817 00 06-16	Screw 3/8-16 x 1
91	532 18 74-95	Bushing

NOTE: All component dimensions given in U.S. inches
1 inch = 25.4 mm

For engine service and replacement parts, call the toll free number for your engine manufacturer listed below:

Briggs & Stratton 1-800-233-3723

Engine Power Rating Information

The gross power rating for individual gas engine models is labeled in accordance with SAE (Society of Automotive Engineers) code J1940 (Small Engine Power & Torque Rating Procedure), and rating performance has been obtained and corrected in accordance with SAE J1995 (Revision 2002-05). Torque values are derived at 3060 RPM; horsepower values are derived at 3600 RPM. Actual gross engine power will be lower and is affected by, among other things, ambient operating conditions and engine-to-engine variability. Given both the wide array of products on which engines are placed and the variety of environmental issues applicable to operating the equipment, the gas engine will not develop the rated gross power when used in a given piece of power equipment (actual "on-site" or net power). This difference is due to a variety of factors including, but not limited to, accessories (air cleaner, exhaust, charging, cooling, carburetor, fuel pump, etc.), application limitations, ambient operating conditions (temperature, humidity, altitude), and engine-to-engine variability. Due to manufacturing and capacity limitations, Briggs & Stratton may substitute an engine of higher rated power for this Series engine.

TRACTOR - MODEL NO. YTH23V48 (96043011003), PRODUCT NO. 960 43 01-10
STEERING ASSEMBLY

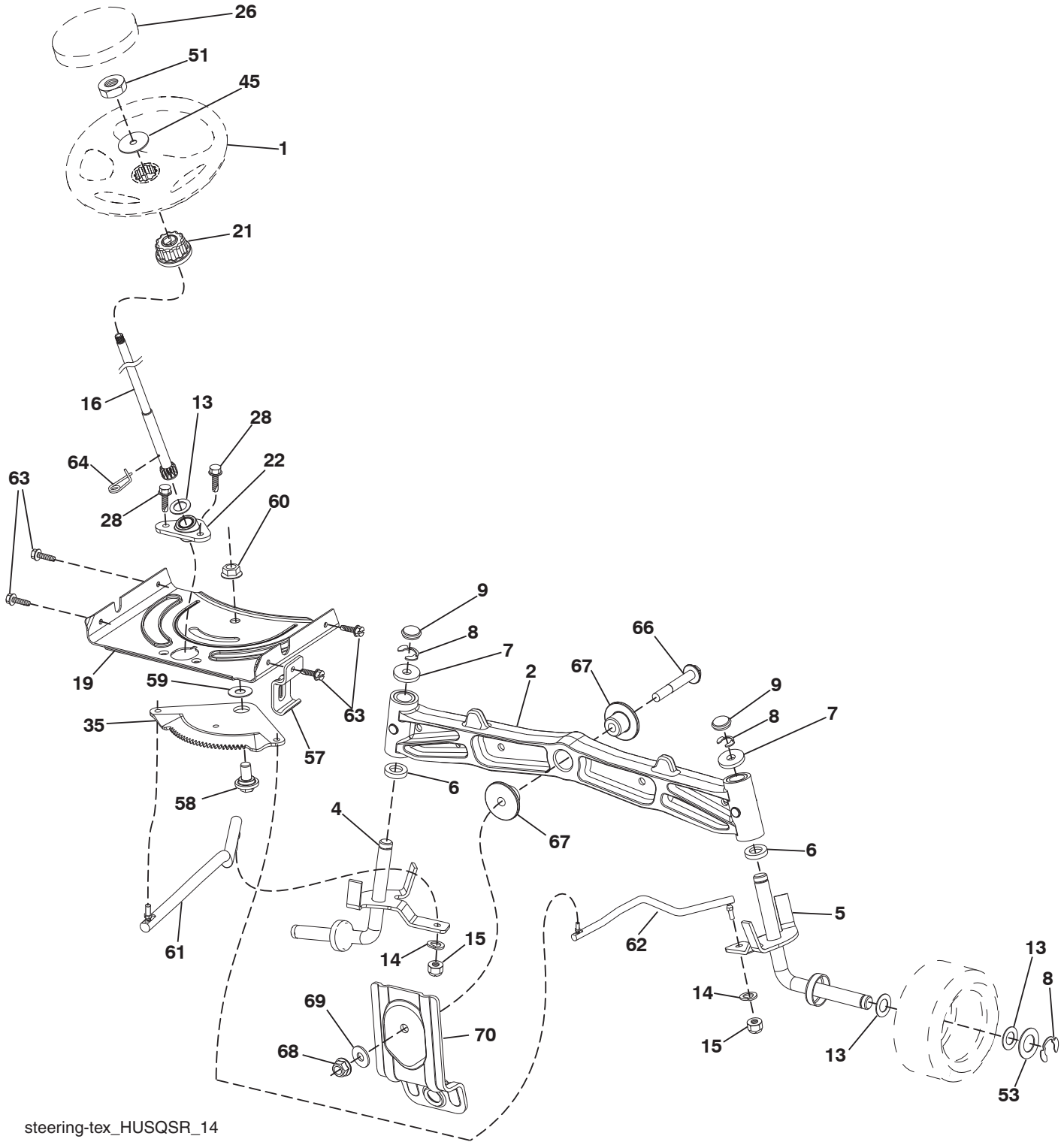

steering-tex_HUSQSR_14

**TRACTOR - MODEL NO. YTH23V48 (96043011003), PRODUCT NO. 960 43 01-10
STEERING ASSEMBLY**

KEY NO.	PART NO.	DESCRIPTION
1	532 43 97-40	Wheel, Steering
2	532 19 59-68	Axle Asm., Front
4	532 40 30-87	Spindle Asm., LH
5	532 40 30-88	Spindle Asm., RH
6	532 12 49-31	Bearing, Race Thrust Harden
7	532 12 17-48	Washer 25/32 x 1-5/8 x 16 Ga.
8	812 00 00-29	Ring, Clip #T5304-75
9	532 12 12-32	Cap, Spindle
13	532 12 17-49	Washer 25/32 x 1-1/4 x 16 Ga.
14	810 04 06-00	Washer, Lock Hvy Hlcl Spr 3/8
15	873 54 06-00	Nut, Crown Lock 3/8-24 unf
16	532 40 82-19	Shaft Steering
19	532 19 47-29	Plate Steering
21	532 18 67-37	Adapter, Wheel Steering
22	532 42 05-37	Steering, Support Lower
26	532 43 97-43	Insert, Wheel Steering
28	817 00 06-12	Screw 3/8-16 x 3/4
35	532 19 47-32	Gear, Sector Plate
45	819 18 38-12	Washer 9/16 x 2-3/8 x 12 Ga.
51	873 94 08-00	Nut Hex Jam Toplock 1/2-20 unf
53	532 18 89-67	WasherHardened.793x1.637x.060
57	532 19 72-46	Bracket Upstop
58	532 19 47-47	Bolt Shoulder Sector Pivot CFM
59	532 19 47-48	Washer Thrust Sector Steering
60	873 97 10-00	Nut Flange Lock 5/8-11
61	532 19 47-40	Draglink, LH
62	532 19 47-41	Draglink, RH
63	817 00 05-12	Screw 5/16-18 x 3/4
64	532 19 98-49	Retainer Clip Spring Steering
66	871 02 07-48	Bolt Hex Fghd 7/16-14 x 3 Serr
67	532 19 47-37	Bushing PM Front Axle
68	873 90 07-00	Nut Lock Flange 7/16-14 Gr. 5
69	532 19 91-62	Washer 1.5 x .505 x .118
70	532 19 61-97	Bracket Deck Susp. Front

NOTE: All component dimensions given in U.S. inches
1 inch = 25.4 mm

TRACTOR - MODEL NO. YTH23V48 (96043011003), PRODUCT NO. 960 43 01-10
MOWER DECK

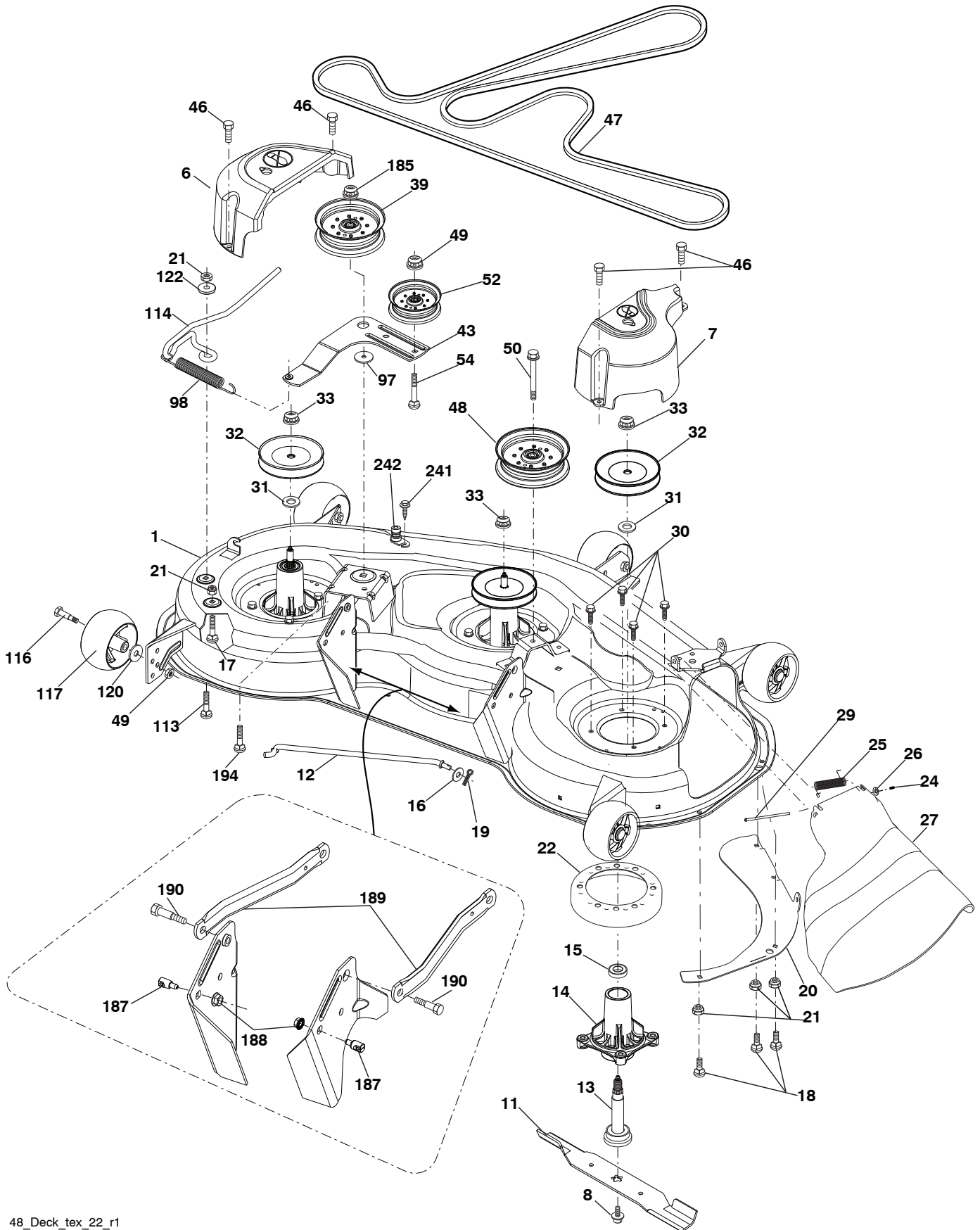

**TRACTOR - MODEL NO. YTH23V48 (96043011003), PRODUCT NO. 960 43 01-10
MOWER DECK**

KEY NO.	PART NO.	DESCRIPTION	KEY NO.	PART NO.	DESCRIPTION
1	532 44 00-48	Deck Weldment Mower	49	873 90 06-00	Nut, Lock Flg. 3/8-16 unc
6	532 19 72-48	Cover Mandrel LH	50	817 49 06-36	Screw TT 3/8-16 x 2-1/4
7	532 19 91-02	Cover Mandrel RH	52	532 19 31-97	Pulley Idler 48" Primary
8	532 19 30-03	Bolt 7/16 Asm. Blade	54	872 11 06-12	Bolt Carr. Sh 3/8-16 x 1-1/2 Gr. 5
11	532 18 00-54	Blade High Lift	97	532 17 85-15	Washer Hardened
12	532 40 48-51	Rod Anti-Sway	98	532 19 61-05	Spring Drive
13	532 18 72-91	Shaft Asm. w/Lower Bearing	113	872 11 05-08	Bolt Rdhd Sqnk 5/16-18 x 3/4
14	532 18 72-81	Housing, Mandrel	114	532 19 74-51	Rod Tension Relief
15	532 11 04-85	Bearing, Ball, Mandrel	116	532 19 34-06	Bolt, Shoulder
16	819 13 13-12	Washer 13/32 x 13/16 x 12 Ga.	117	532 17 48-73	Gauge Wheel
17	872 11 05-05	Bolt 5/16-18 x 5/8	120	819 13 20-12	Washer 13/32 x 1-1/4 x 12 Ga.
18	872 14 05-05	Bolt RdHd 5/16-18 unc x 5/8	122	532 18 75-57	Bushing Tension Relief
19	532 19 42-08	Pin Cotter 5/16 Bow Tie Lock	185	873 90 07-00	Nut Lock Flange 7/16-14 Gr. 5
20	532 17 43-78	Baffle Vortex	187	532 19 51-61	Stud Fastener w/"D" Anti-Rotation
21	873 68 05-00	Nut, Crownlock 5/16-18 unc	188	873 90 05-00	Nut Lock Hex Flange
22	532 17 44-93	Stripper Mandrel	189	532 19 51-85	Arm Susp. Mower Rear
24	532 10 53-04	Cap Sleeve	190	532 19 65-39	Bolt Shoulder
25	532 17 81-02	Spring, Torsion	194	874 49 07-36	Bolt Hex Washer Head 7/16-14 x 2.25
26	532 11 04-52	Nut, Push	241	532 15 29-27	Screw TT #10-32.5 3/8 Flange
27	532 18 17-07	Deflector Shield	242	532 41 55-98	Port, Washout
29	532 13 14-91	Rod, Hinge	--	532 41 64-05	Coupling Quick Connect
30	532 17 39-84	Screw, Thdroll Washer Head	--	532 18 72-92	Mandrel Assembly (Includes housing, shaft assembly, and bearing only - pulley/nut/washer and blade bolt/washers not included)
31	532 18 76-90	Washer, Spacer Mower Vented	--	532 43 18-25	Replacement Mower, Complete
32	532 15 35-32	Pulley, Mandrel			
33	532 40 02-34	Nut, Flg. Top Lock			
39	532 19 73-80	Pulley, Idler, 4.50 Hub			
43	532 19 60-65	Arm, Idler			
46	532 13 77-29	Screw, Thdroll. 1/4-20 x 5/8			
47	532 19 72-42	Belt Deck Drive			
48	532 19 73-79	Pulley Idler 4.50 RAW			

NOTE: All component dimensions given in U.S. inches
1 inch = 25.4 mm

**TRACTOR - MODEL NO. YTH23V48 (96043011003), PRODUCT NO. 960 43 01-10
MOWER LIFT**

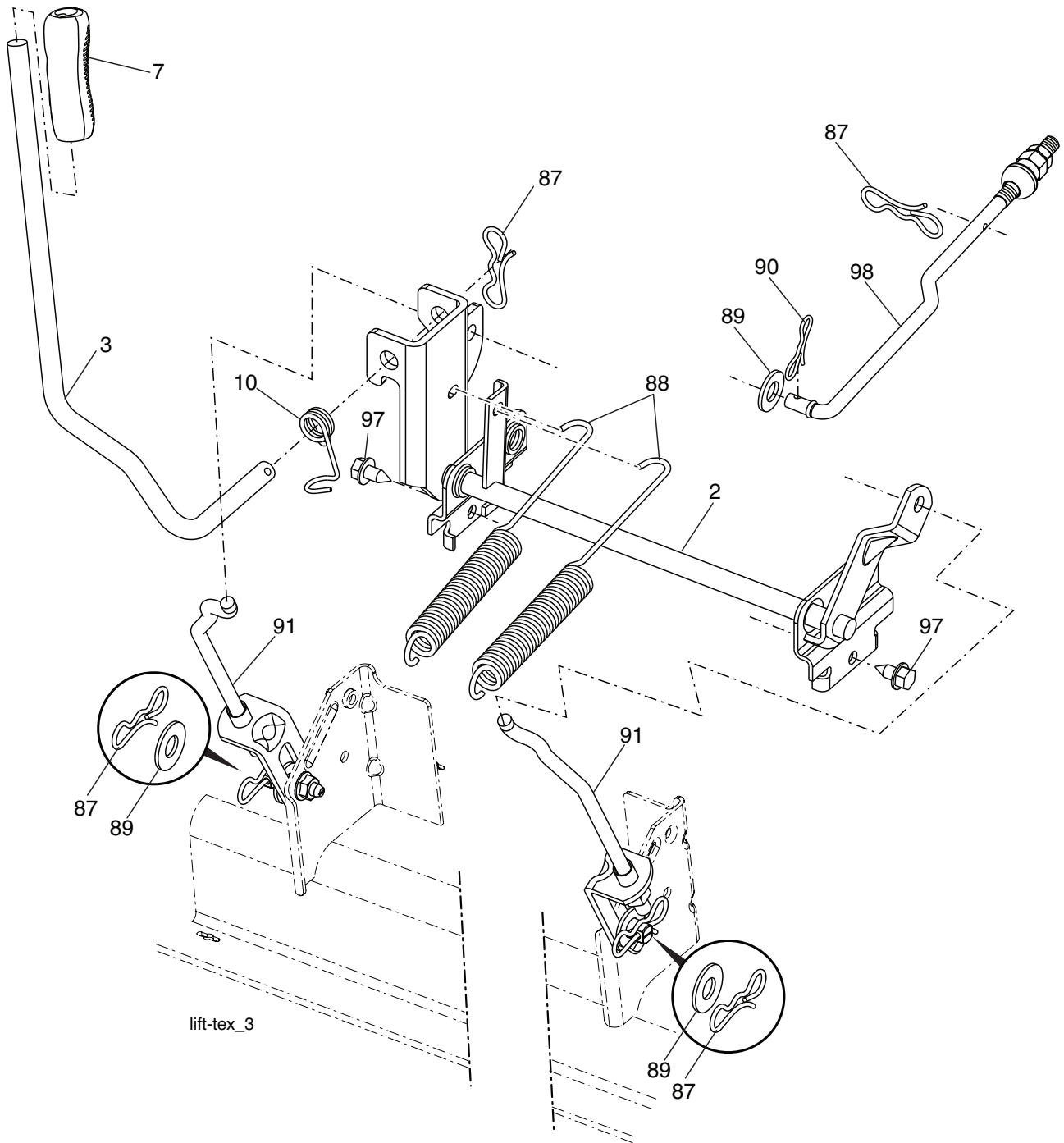

KEY NO.	PART NO.	DESCRIPTION
2	532 42 20-27	Shaft Asm. Cross, Lift
3	532 19 52-31	Lever Asm., Lift
7	532 41 15-55	Grip, Lever
10	532 19 63-14	Spring Torsion
87	532 19 42-09	Pin Cotter 7/16 Bow Tie Lock
88	532 41 07-10	Spring Lift Assist
89	819 19 19-12	Washer Clear Zinc

KEY NO.	PART NO.	DESCRIPTION
90	532 19 42-08	Pin Cotter 5/16 Bow Tie Lock
91	532 19 51-81	Link Lift Susp Mower Rear
97	817 00 06-12	Screw 3/8-16 x .75
98	532 19 52-64	Link Lift Susp. Front Mower

NOTE: All component dimensions given in U.S. inches
1 inch = 25.4 mm

**TRACTOR - MODEL NO. YTH23V48 (96043011003), PRODUCT NO. 960 43 01-10
SEAT ASSEMBLY**

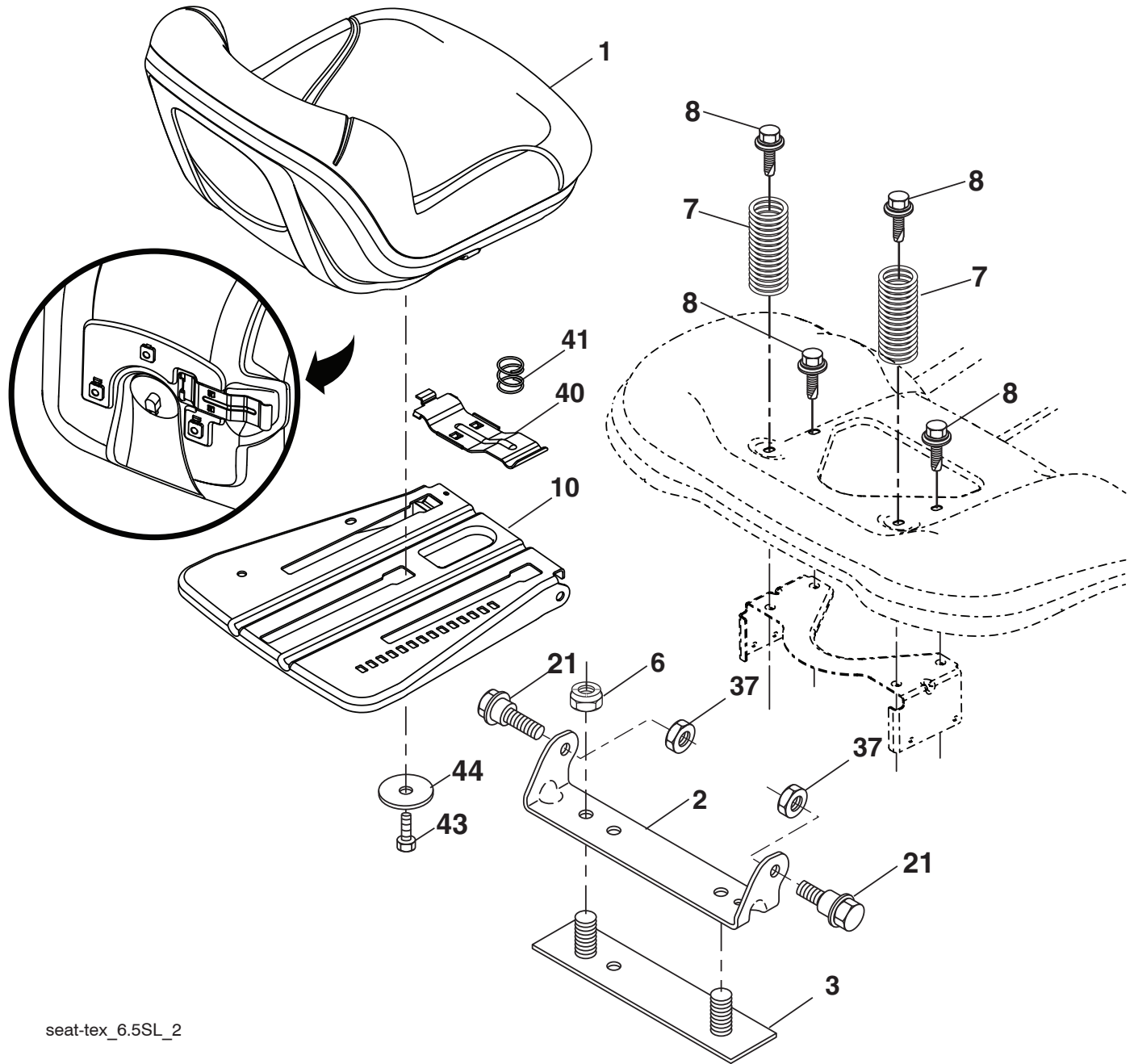

seat-tex_6.5SL_2

KEY NO.	PART NO.	DESCRIPTION
1	532 43 98-22	Seat
2	532 18 01-66	Bracket Pivot Fender
3	532 14 06-75	Strap, Asm Fender
6	873 80 06-00	Nut, Lock w/Ins. 3/8-16 unc
7	532 12 41-81	Spring, Seat Cprsn
8	532 17 18-77	Bolt 5/16-18 unc x 3/4 w/Sems
10	532 19 69-77	Pan, Seat
21	532 17 18-52	Bolt, Shoulder 5/16-18

KEY NO.	PART NO.	DESCRIPTION
37	873 80 05-00	Nut, Lock 5/16-18 unc
40	532 19 76-61	Handle Slide Seat
41	532 19 82-00	Spring Latch Seat
43	874 76 06-12	Bolt 3/8-16 x 3/4
44	819 13 38-12	Washer 13/32 x 2-3/8 x 12 Ga.

NOTE: All component dimensions given in U.S. inches
1 inch = 25.4 mm

**TRACTOR - MODEL NO. YTH23V48 (96043011003), PRODUCT NO. 960 43 01-10
DECALS**

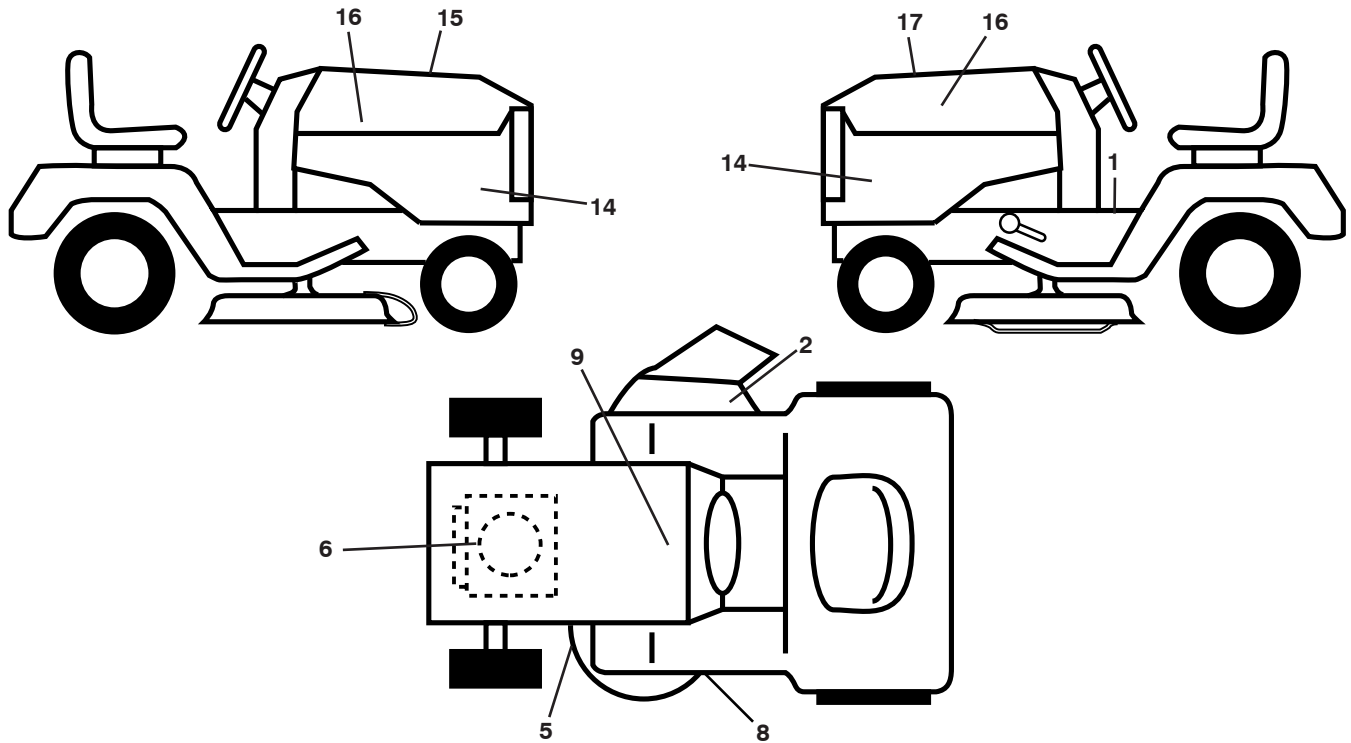

KEY NO.	PART NO.	DESCRIPTION
1	532 41 16-57	Decal, Warning
2	532 17 05-63	Decal, Mower Warn. Keep Hand Away
5	532 17 84-55	Decal, Caution
6	532 42 95-57	Decal, Eng.
8	532 19 87-85	Decal, Mower Sch.
9	532 14 50-05	Decal, Battery Dnge/Poi
14	532 43 86-63	Decal, Panel Side
15	532 42 38-29	Decal, Cust. Resp.

KEY NO.	PART NO.	DESCRIPTION
16	532 42 91-96	Decal, Hood Logo
17	532 43 84-78	Decal, Replacement
--	532 16 69-60	Decal, Bypass
--	532 43 96-81	Pad, Footrest, LH
--	532 43 96-82	Pad, Footrest, RH
--	532 44 55-30	Manual, Operator's (English/Spanish)
--	532 44 55-31	Manual, Repair Parts (English/Spanish)

WHEELS AND TIRES

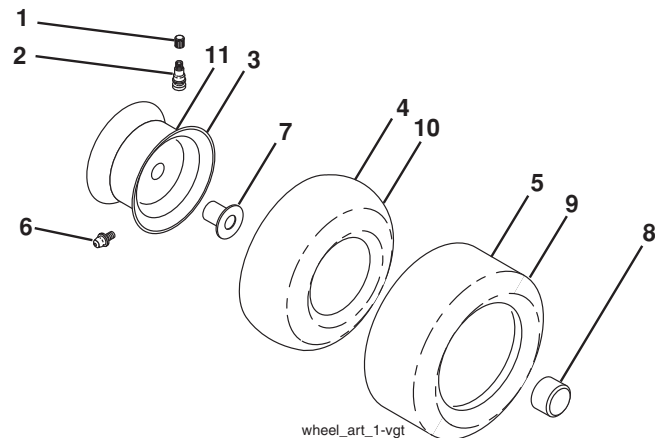

KEY NO.	PART NO.	DESCRIPTION
1	532 05 91-92	Cap, Valve, Tire
2	532 06 51-39	Stem, Valve
3	532 13 83-36	Rim Assembly, Front
4	532 05 99-04	Tube, Front (Service Item Only)
5	532 10 62-22	Tire, Front
6	532 12 49-57	Fitting, Grease (Front Wheel Only)
7	532 12 49-59	Bearing, Flange (Front Wheel Only)
8	532 17 50-39	Cap, Axle
9	532 13 84-68	Tire, Rear
10	532 12 49-26	Tube, Rear (Service Item Only)
11	532 13 83-37	Rim Assembly, Rear
--	532 14 43-34	Sealant, Tire (10 oz. Tube)

NOTE: All component dimensions given in U.S. inches
1 inch = 25.4 mm